

# PRODUCT INFORMATION PACKET



Model No: 048A17T72

Catalog No: X301

Fan and Blower Motor, 0.17 HP, 1 Ph, 60 Hz, 115 V, 1800 RPM, 48Z Frame, TEAO



Regal and LEESON are trademarks of Regal Rexnord Corporation or one of its affiliated companies.  
©2025 Regal Rexnord Corporation, All Rights Reserved. MC017097E





### Nameplate Specifications

Phase	1	Output HP	0.17 Hp
Output KW	0.13 kW	Voltage	115 V
Speed	1625 rpm	Service Factor	1.0
Frame	48Z	Enclosure	Totally Enclosed Air Over
Thermal Protection	Automatic	Efficiency	55 %
Ambient Temperature	40 °C	Frequency	60 Hz
Current	2.2 A	Power Factor	89.4
Duty	Continuous	Insulation Class	B
Design Code	NO DESIGN CODE	KVA Code	C
Drive End Bearing Size	6203	Opp Drive End Bearing Size	6203
UL	Recognized	CSA	Y
CE	N	IP Code	43
Number of Speeds	1		

### Technical Specifications

Electrical Type	Permanent Split Capacitor	Starting Method	Across The Line
Poles	4	Rotation	Selective Counterclockwise
Resistance Main	0 Ohms	Mounting	Resilient Base - Extended Studs
Motor Orientation	Horizontal	Drive End Bearing	Ball
Opp Drive End Bearing	Ball	Frame Material	Rolled Steel
Shaft Type	Single Special Extension	Overall Length	9.00 in
Frame Length	4.75 in	Shaft Diameter	0.500 in
Shaft Extension	2.81 in	Assembly/Box Mounting	F1 ONLY
Connection Drawing	9513130	Outline Drawing	A-SS74126-475

This is an uncontrolled document once printed or downloaded and is subject to change without notice. Date Created:07/29/2025

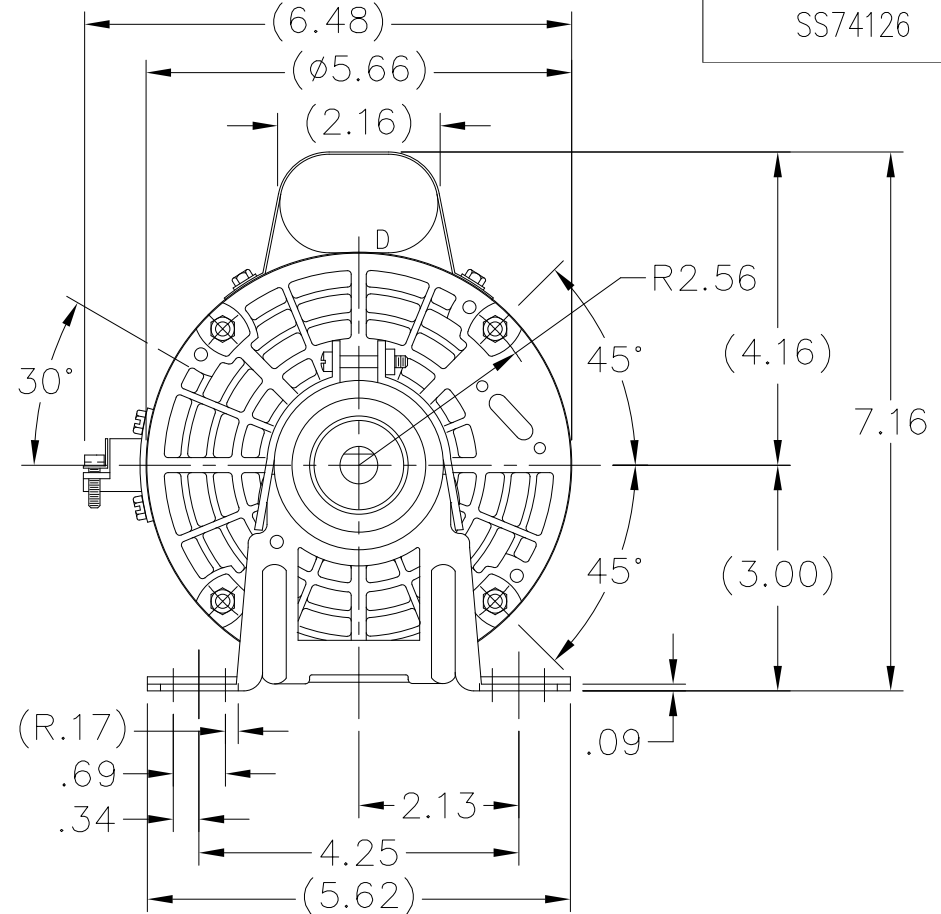
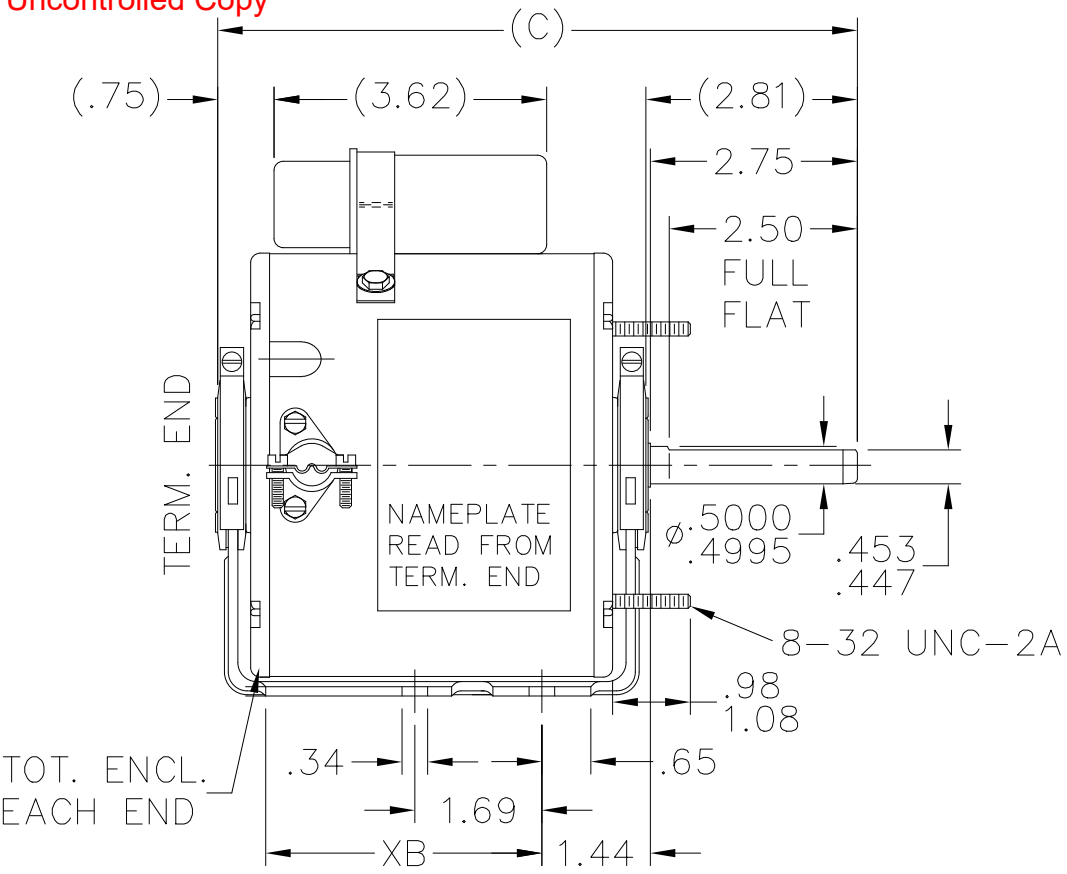

LEAD DESCRIPTION:  
 1 BLACK AND 1 WHITE LEAD WITH .50 BARE WIRE STRIP EXIT MOTOR THROUGH CONDUIT CONNECTOR WITH ADJUSTABLE THROAT OPENING. 35.00-37.00" LONG PURPLE AND YELLOW REVERSING LEADS MOLDED INTO MATING PULL-APART PLUGS. 4.00-6.00 LONG.

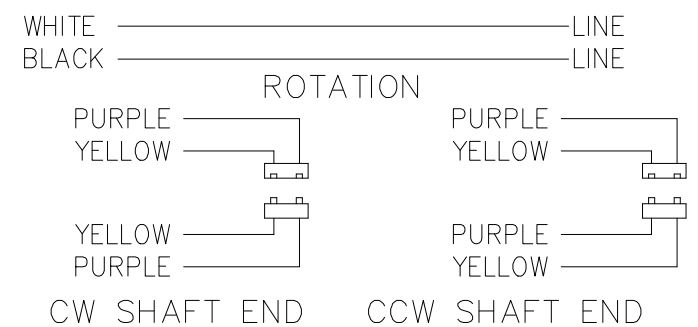

DASH	C	XB
425	8.50	3.67
475	9.00	4.17

NO.	REVISION	BY & DATE	CHK	TOLERANCES UNLESS SPECIFIED	
				DEC.	INCHES
5	CHG FROM MARATHON TO RRX TEMPLATE PER ECR-0233452	MD 4/30/24	DS	.X	±.1
4	REVISED MOUNTING HOLE LOCATIONS	RJW 07-12-2005	ML	.XX	±.03
3	REDRAWN IN AUTOCAD	TAT 05-19-2005	ML	.XXX	±.005
2	REDRAWN ON CADD - NO CHANGE	MRB 04-01-1998		.XXXX	±.0005
			ANG		±7'30"

**Regal Rexnord** Regal Beloit America, Inc.

TITLE OUTLINE

MAT'L.

FINISH

CAD FILE ss74126

DRAWN MRB 03-10-1998
CHK ML 04-01-1998
APPD GK 04-01-1998
SCALE 3=8
REF
FMF
PREV

THIS DRAWING IN DESIGN AND DETAIL IS OUR PROPERTY AND MUST NOT BE USED EXCEPT IN CONNECTION WITH OUR WORK ALL RIGHTS OF DESIGN AND INVENTION ARE RESERVED THIS IS AN ELECTRONICALLY GENERATED DOCUMENT - DO NOT SCALE THIS PRINT

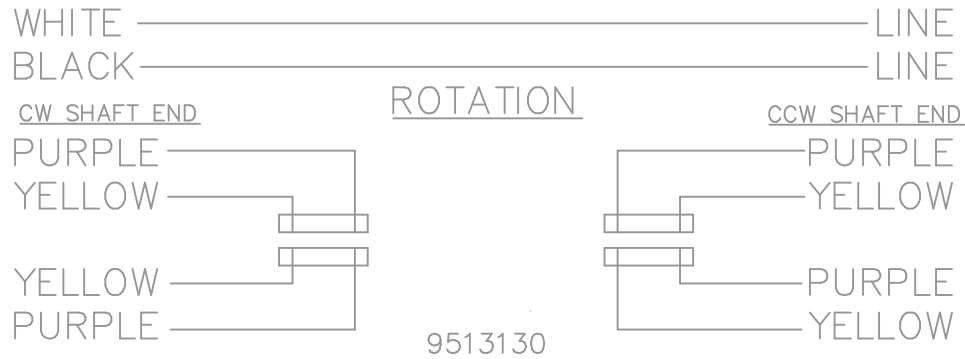

				TOLERANCES UNLESS SPECIFIED			DRAWN TOM 09/19/1988		
				DEC.	INCHES		CHK		
				.X	±.1		APPD MS 09/20/1988		
				.XX	±.02		SCALE 1=1		
3	REDRAWN IN AUTOCAD	JMS 03/11/2005		.XXX	±.005	TITLE CONNETION DIAGRAM		REF	
2	NEW DRAWING	TOM 09/19/1988		.XXXX	±.0005	MAT'L.		FMF	
NO.	REVISION	BY & DATE	CHK	ANG	±7'30"	FINISH		PREV	
THIS DRAWING IN DESIGN AND DETAIL IS OUR PROPERTY AND MUST NOT BE USED EXCEPT IN CONNECTION WITH OUR WORK ALL RIGHTS OF DESIGN AND INVENTION ARE RESERVED THIS IS AN ELECTRONICALLY GENERATED DOCUMENT - DO NOT SCALE THIS PRINT				RFP	CAD FILE 9513130		SIZE	DRAWING NO. PAGE OF	REV.
				DIST	WP	A	9513130	3	



\*\* Subject to change without notice.