

PRODUCT INFORMATION PACKET



Model No: 048S17D2058

Catalog No: B306

Fan and Blower Motor, 0.50 HP, 1 Ph, 60 Hz, 115 V, 1800 RPM, 48Y Frame, DP



Regal and LEESON are trademarks of Regal Rexnord Corporation or one of its affiliated companies.
©2025 Regal Rexnord Corporation, All Rights Reserved. MC017097E





Nameplate Specifications

Phase	1	Output HP	0.50 Hp
Output KW	0.37 kW	Voltage	115 V
Speed	1725 rpm	Service Factor	1.25
Frame	48Y	Enclosure	Drip Proof
Thermal Protection	No Protection	Efficiency	66 %
Ambient Temperature	40 °C	Frequency	60 Hz
Current	7.5 A	Power Factor	69.6
Duty	Continuous	Insulation Class	B
Design Code	NO DESIGN CODE	KVA Code	M
Drive End Bearing Size	6203	Opp Drive End Bearing Size	6203
UL	Recognized	CSA	Y
CE	N	IP Code	22
Number of Speeds	1		

Technical Specifications

Electrical Type	Split Phase	Starting Method	Across The Line
Poles	4	Rotation	Selective Counterclockwise
Resistance Main	0 Ohms	Mounting	Resilient Base - Extended Studs
Motor Orientation	Horizontal	Drive End Bearing	Ball
Opp Drive End Bearing	Ball	Frame Material	Rolled Steel
Shaft Type	Single Special Extension	Overall Length	10.32 in
Shaft Diameter	0.500 in	Shaft Extension	1.88 in
Assembly/Box Mounting	F1 ONLY		
Connection Drawing	52A105377AA	Outline Drawing	52A111273P2

This is an uncontrolled document once printed or downloaded and is subject to change without notice. Date Created:07/29/2025

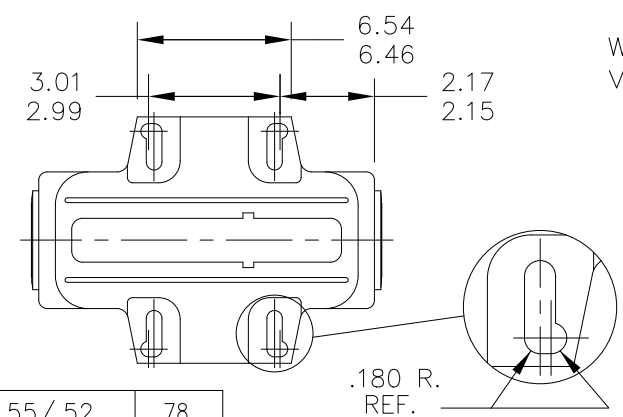
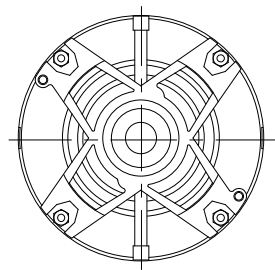
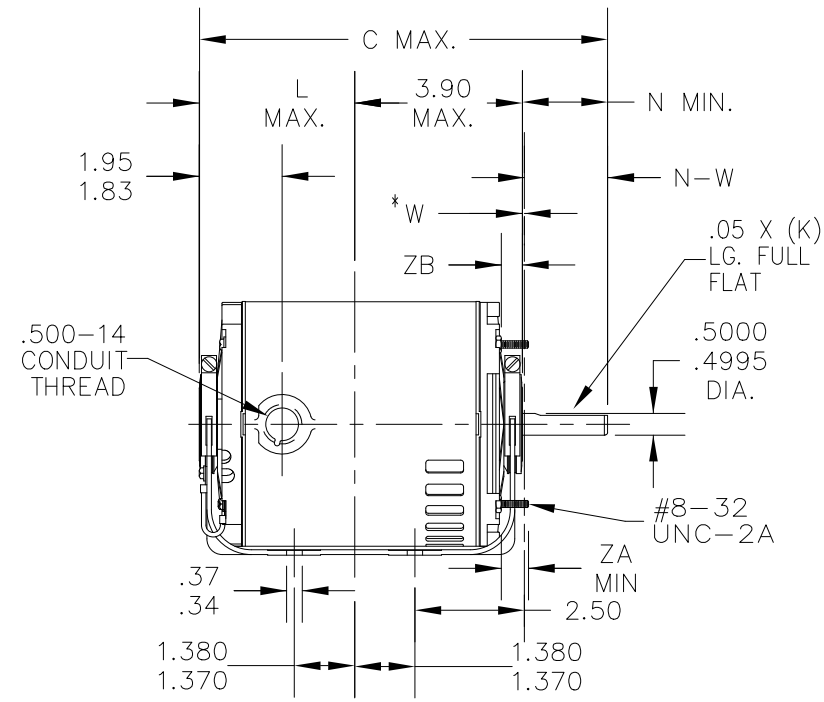
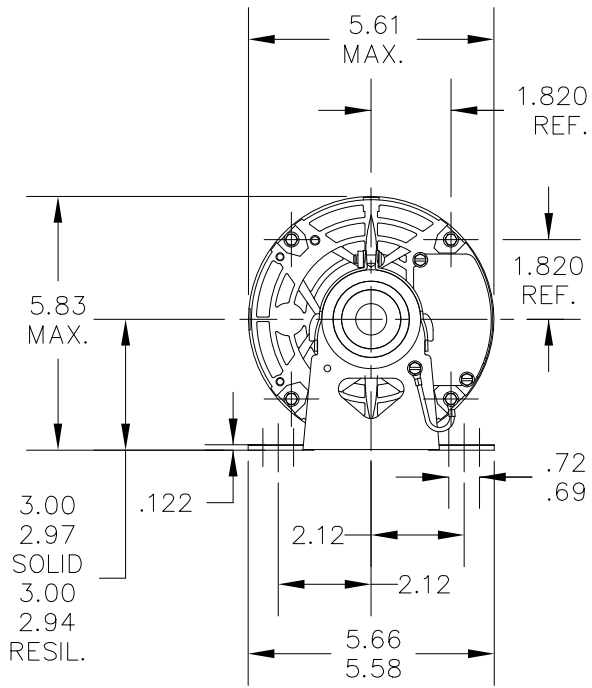

W* IS A CLEARANCE DUE TO VARIATION IN PARTS AND ASSEMBLY.

2	KH	36	48Y	10.32	1.62	4.50	1.88	2.01/1.79	.55/.52	.78
1	KH	32	48Y	9.32	1.62	3.59	1.88	2.01/1.79	.55/.52	.78
P	TYPE	RBC SIZE	NEMA FR	C	K	L	N	N-W	ZB	ZA

NO.	REVISION	BY & DATE	CHK	TOLERANCES UNLESS SPECIFIED	
				ANG	±7'30"
6	CHG FROM MARATHON TO REGAL REXNORD LOGO	KVDG 05-10-2024	DS	DEC.	INCHES
5	LOGO WAS DAYTON	PVR 06/13/13	ST	.X	±0.1
4	CHANGED 'ZA' DIMENSION PER IS12-5406	UD 11/07/12	DS	.XX	±0.02
3	UPDATED AS PER IS05-2299	PKG 09/14/05		.XXX	±0.005
2	CHG MADE PER IS05-1477	PKG 06/29/05		.XXXX	±0.0005

		Regal Beloit America, Inc.	
TITLE		OUTLINE	
		DRIP PROOF- RESIL. BASE - BALL	
MAT'L.			
FINISH			

DRAWN	DS 01/05/05
CHK	
APPD	DS 01/05/05
SCALE	1=1
REF	
FMF	
PREV	

SHEET 1
REV 1
52A105377AA 1

THIRD ANGLE PROJECTION

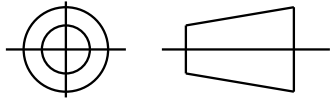

REVISIONS

REV.	DESCRIPTION	DATE	APPROVED
1	UPDATED FORMAT	11/10/05	MAM

EITHER ROTATION - SINGLE VOLTAGE
TYPE KC, OR KH

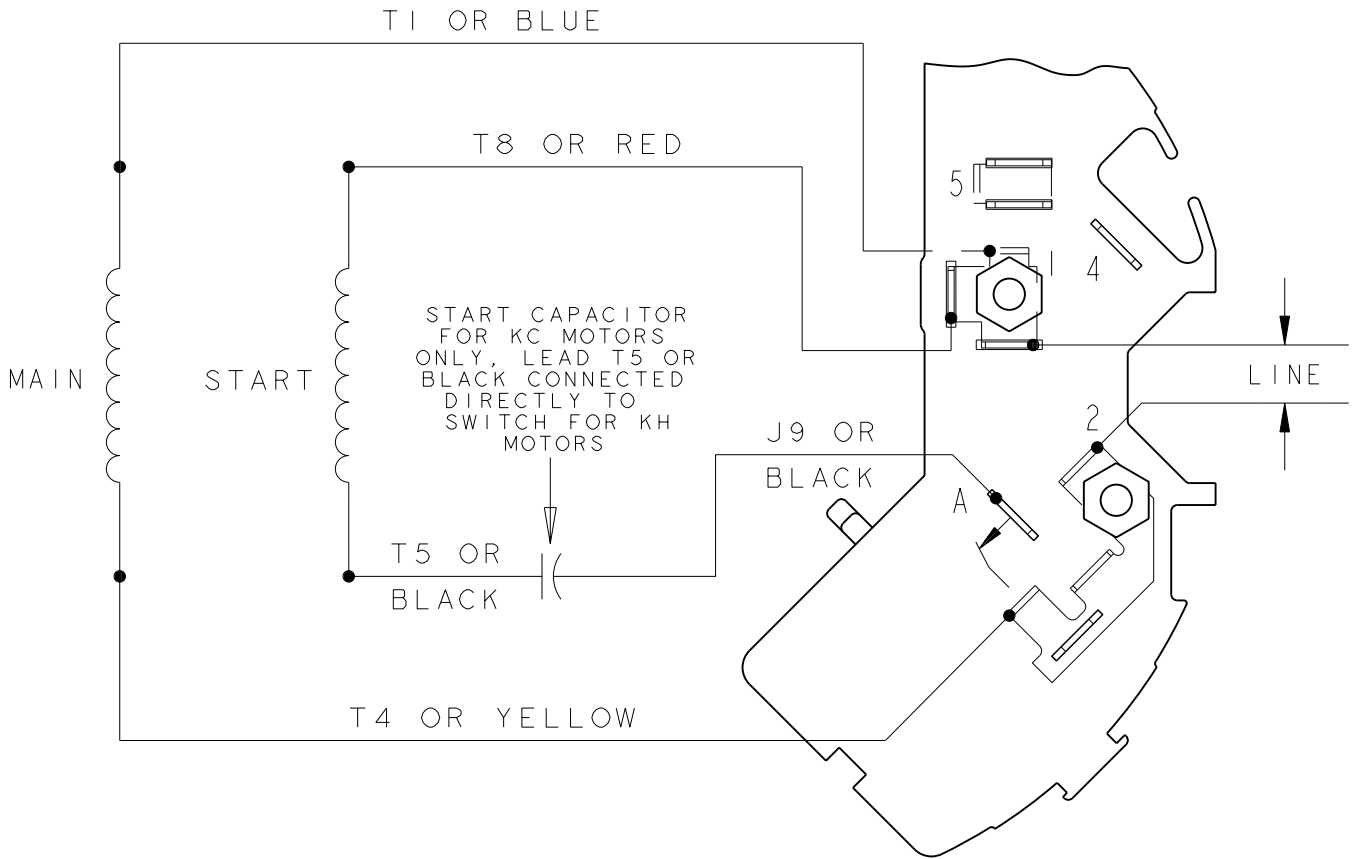

NOTE #1 - TO REVERSE ROTATION INTERCHANGE BLACK (T5-KH OR J9-KC) AND RED (T8) LEADS.

NOTE #2 - WHEN MORE THAN ONE CAPACITOR IS USED CONNECT IN PARALLEL.

REF. DIAG. - 121A850		SWITCH (C) - 115D958AB	
CONNECTION LABEL - 52X332047			
SIGNATURES	DATE	REGAL-BELOIT CORPORATION CONNECTION DIAGRAM FMF: 30 FRAME SWITCH REDESIGN	
MODEL M.D. PAPE	06/29/87		
DETAIL	.		
CHECKED	.		
ENGRG	.		
MFG	.		
FOR ADDITIONAL INFO REFER TO:	QUALITY	SIZE	DRAWING
APPLIED PRACTICES	ISSUED M.D.P. 06/29/87	A	52A105377AA
DIMENSIONS ARE IN INCHES ✓	SOLID MODEL: 52A105377AA	SCALE: 1.000	REF. No: .
MATERIAL			SHEET 1 of 1



MODEL #: 48S17D2058 N

CONN. DIAGRAM: 52A105377AA

OUTLINE: 52A111273P2

MOUNTING: F1 ONLY

WINDING #: 52X331851P1 0

TYPICAL MOTOR PERFORMANCE DATA

HP	kW	SYNC. RPM	F.L. RPM	FRAME	ENCLOSURE	KVA CODE	DESIGN
1/2	0.37	1800	1725	48Y	DP	M	NO DESIGN CODE

PH	Hz	VOLTS	AMPS	START TYPE	DUTY	INSL	S.F.	AMB°C
1	60	115	7.5	ACROSS THE LINE	CONTINUOUS	B3	1.25	40

FULL LOAD EFF:	66	3/4 LOAD EFF:	68	1/2 LOAD EFF:	64	GTD. EFF		ELEC. TYPE	
FULL LOAD PF:	69.6	3/4 LOAD PF:	61	1/2 LOAD PF:	49	70		SPLIT PHASE	

F.L. TORQUE	LOCKED ROTOR AMPS	L.R. TORQUE	B.D. TORQUE	F.L. RISE°C
36.5 OZ-FT	44.2	49.4 OZ-FT 135 %	79 OZ-FT 216 %	75

SOUND PRESSURE @ 3 FT.	SOUND POWER	ROTOR WK^2	MAX. WK^2	SAFE STALL TIME	STARTS / HOUR	APPROX. MOTOR WGT
- dBA	- dBA	0 LB-FT^2	- LB-FT^2	10 SEC.	-	22 LBS.

***** SUPPLEMENTAL INFORMATION *****

DE BRACKET TYPE	ODE BRACKET TYPE	MOUNT TYPE	ORIENTATION	SEVERE DUTY	HAZARDOUS LOCATION	DRIP COVER	SCREENS	PAINT
STANDARD	STANDARD	RESILIENT BASE-EXTENDED STUDS	HORIZONTAL	FALSE	NONE	FALSE	NONE	GRAY (POWDER)

BEARINGS		GREASE	SHAFT TYPE	SPECIAL DE	SPECIAL ODE	SHAFT MATERIAL	FRAME MATERIAL
DE	ODE						
BALL	BALL	BEACON 325	SGL SPL EXT	0.500 x 1.88 IN SEF WITH 1.62 IN FULL FLAT	NONE	1144 STRESSPROOF (C-223)	ROLLED STEEL
6203	6203						

THERMO-PROTECTORS				THERMISTORS	CONTROL	SPACE HEATERS
THERMOSTATS	PROTECTORS	WDG RTDs	BRG RTDs			
NONE	NOT	NONE	NONE	NONE	FALSE	NONE VOLTS

*
N
O
T
E
S
*

INVERTER TORQUE: NONE
INV. HP SPEED RANGE: NONE
ENCODER: NONE
NONE NONE
NONE NONE PPR
BRAKE: NONE NONE
NONE P/N NONE
NONE NONE
NONE FT-LB NONE V NONE Hz