

PRODUCT INFORMATION PACKET



Model No: 098007.00
Catalog No: 098007.00
SCR Motor, 0.50 HP, 180 V, 2500 RPM, SS56C Frame, TEFC



Regal and LEESON are trademarks of Regal Rexnord Corporation or one of its affiliated companies.
©2025 Regal Rexnord Corporation, All Rights Reserved. MC017097E





Nameplate Specifications

Output HP	0.50 Hp	Output KW	0.37 kW
Voltage	180 V	Speed	2500 rpm
Service Factor	1.0	Frame	SS56C
Enclosure	Totally Enclosed Fan Cooled	Thermal Protection	No Protection
Efficiency	80.5 %	Ambient Temperature	40 °C
Current	2.5 A	Duty	Continuous
Insulation Class	F	Drive End Bearing Size	6203
Opp Drive End Bearing Size	6203	UL	Recognized
CSA	Y	CE	N

Technical Specifications

Rotation	Reversible	Mounting	Rigid C base
Overall Length	10.81 in	Frame Length	6.50 in
Shaft Diameter	0.625 in	Shaft Extension	2.06 in
Torque	12.6 LB-IN		
Outline Drawing	027620-098007	Connection Drawing	00531901

This is an uncontrolled document once printed or downloaded and is subject to change without notice. Date Created:04/08/2025

RBC PROPRIETARY AND CONFIDENTIAL INFORMATION
 This document is the property of REGAL BELOIT CORPORATION ("RBC") including its subsidiaries and divisions and contains proprietary information of RBC. This document is loaned on the express condition that neither it nor the information contained therein shall be disclosed to others without the express written consent of RBC, and that the information shall be used by the recipient only as approved expressly by RBC. This document shall be returned to RBC upon its request. This document may be subject to certain restrictions under U.S. export control laws and regulations.

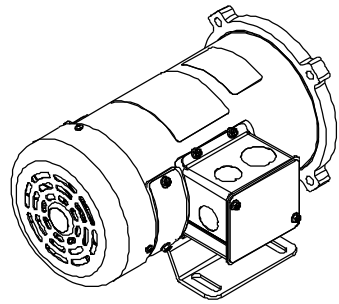
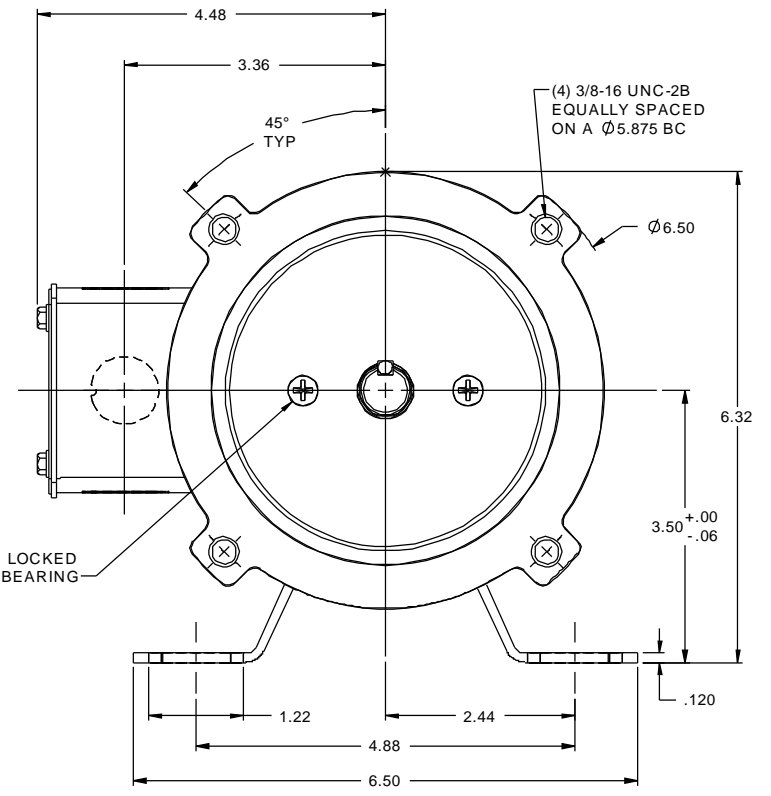
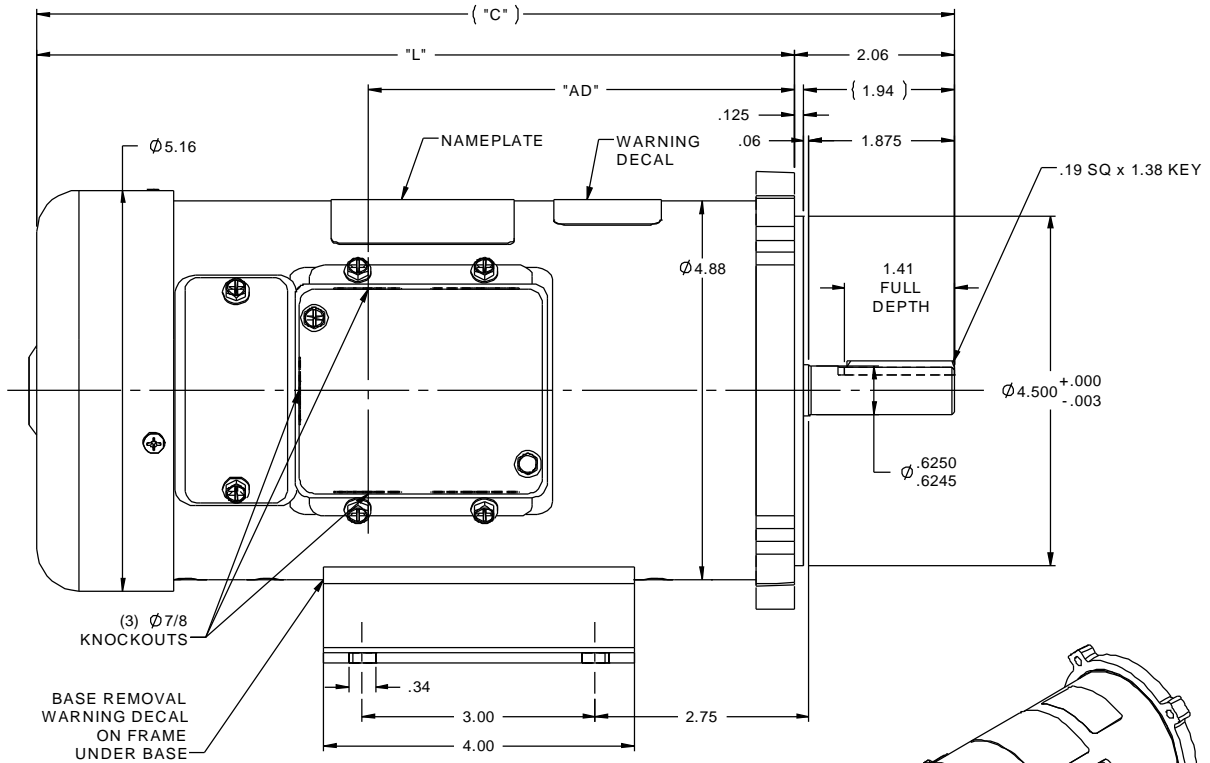

- NOTES:
 1) MAXIMUM FACE RUNOUT .004 T.I.R.
 2) MAXIMUM PILOT ECCENTRICITY .004 T.I.R.
 3) PERMISSIBLE SHAFT RUNOUT .002 T.I.R.
 4) GASKETS THROUGHOUT.

098382.00	10.81	8.75	4.49	48	1/2	1800
098381.00	10.81	8.75	4.49	36	1/2	1800
098069.00	13.81	11.75	7.49	180	3/4	1750
098032.00	13.81	11.75	7.49	90	3/4	1750
098010.00	11.81	9.75	5.49	180	3/4	2500
098009.00	11.81	9.75	5.49	90	3/4	2500
098008.00	11.81	9.75	5.49	180	1/2	1750
098007.00	10.81	8.75	4.49	180	1/2	2500
098006.00	10.81	8.75	4.49	90	1/2	2500
098005.00	11.31	9.25	4.99	180	1/3	1750
098004.00	11.31	9.25	4.99	90	1/3	1750
098003.00	11.31	9.25	4.99	180	1/4	1750
098002.00	10.81	8.75	4.49	90	1/4	1750
098000.00	11.81	9.75	5.49	90	1/2	1750
CATALOG No.	"C"	"L"	"AD"	VOLTS	H.P.	RPM

		TOLERANCES UNLESS SPECIFIED		DRAWN JRA 5/11/95	
		DEC INCHES		CHK	
		X ±.1		APPR	
08	REDRAWN IN SOLIDWORKS, MODIFIED TABLE PER NEW STANDARD	IPG 9/8/2011	XX ±.03	TITLE OUTLINE	SCALE 5:8
			XXX ±.005	42 FRAME DC - SS56C MOUNT	REF RDOUT42DC8
07	ADDED FAN GUARD HOLE PLUG, ISAAC 10-4174	IPG 10/11/10	XXXX ±.0005	MATL	FMF C42D17FK1
NO	REVISION	BY & DATE	CHK LANG ±1/2°	FINISH	PAGE OF
THIRD ANGLE PROJECTION		RFP	PREV	SIZE	DRAWING NO
		NETWORK FILE NAME 027620		B	027620
				REV	08



ELECTRIC MOTORS
 GEARMOTORS
 AND DRIVES

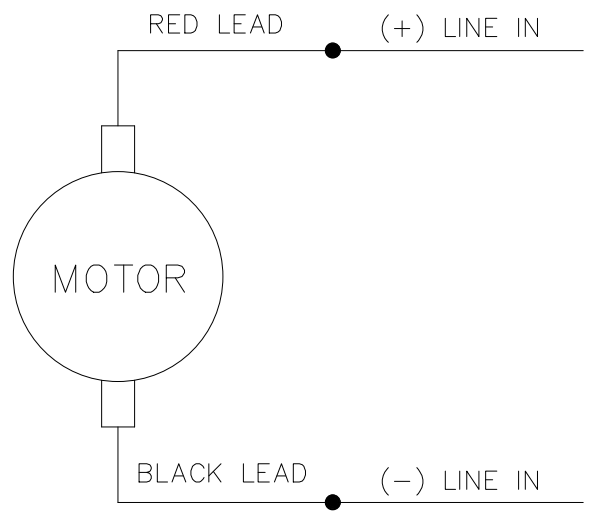

CONNECTIONS SHOWN FOR CCW ROTATION FACING LEAD END OF THE MOTOR
 TO REVERSE ROTATION INTERCHANGE LINE LEADS

				TOLERANCES UNLESS SPECIFIED		 Regal Beloit America, Inc.	DRAWN TJF 11/15/97			
				DEC.	INCHES		CHK			
F	CHG FROM LEESON TO RRX TEMPLATE AS PER ECR-0237142	KVDG 09/19/24	DS	.X	±.1	TITLE	EXTERNAL WIRING DIAGRAM			
E	"MOTOR" WAS "ARMATURE", ECO-0163602	IPG 3/14/19		.XX	±.01		PMDC MOTOR			
D	UPDATED TO MAKE IT GENERIC, ECO-0163547	IPG 3/13/19		.XXX	±.005		SCALE 1=2			
01	REDRAWN ON CAD. REVISED NOTES.	SJB 9/20/2005		.XXXX	±.0005	MAT'L.	REF			
NO.	REVISION	BY & DATE	CHK	ANG	±1/2"		FINISH	FMF		
THIS DRAWING IN DESIGN AND DETAIL IS OUR PROPERTY AND MUST NOT BE USED EXCEPT IN CONNECTION WITH OUR WORK ALL RIGHTS OF DESIGN AND INVENTION ARE RESERVED THIS IS AN ELECTRONICALLY GENERATED DOCUMENT - DO NOT SCALE THIS PRINT				RFP	CAD FILE		00531901	SIZE	DRAWING NO.	REV.
				DIST				A	005319.01	F
										4 of 5

LEESON ELECTRIC CORPORATION

TYPICAL PERFORMANCE CURVE FOR DIRECT CURRENT PERMANENT MAGNET MOTOR

Model No. <u>C42D28FK2C</u>	Catalog No. <u>098007.00</u>	
HP <u>0.500</u>	RPM <u>2500</u>	DC Volts <u>180.0</u>
F.F. <u>1.38</u>	Encl <u>TEFC</u>	Type <u>DF</u>
Max. Amb. <u>40.0 Deg C</u>	Insul. <u>F</u>	Frame <u>LSS56C</u>
		N.P. FLA <u>2.50</u>
		S.F. <u>1.00</u>
		Duty <u>Cont</u>

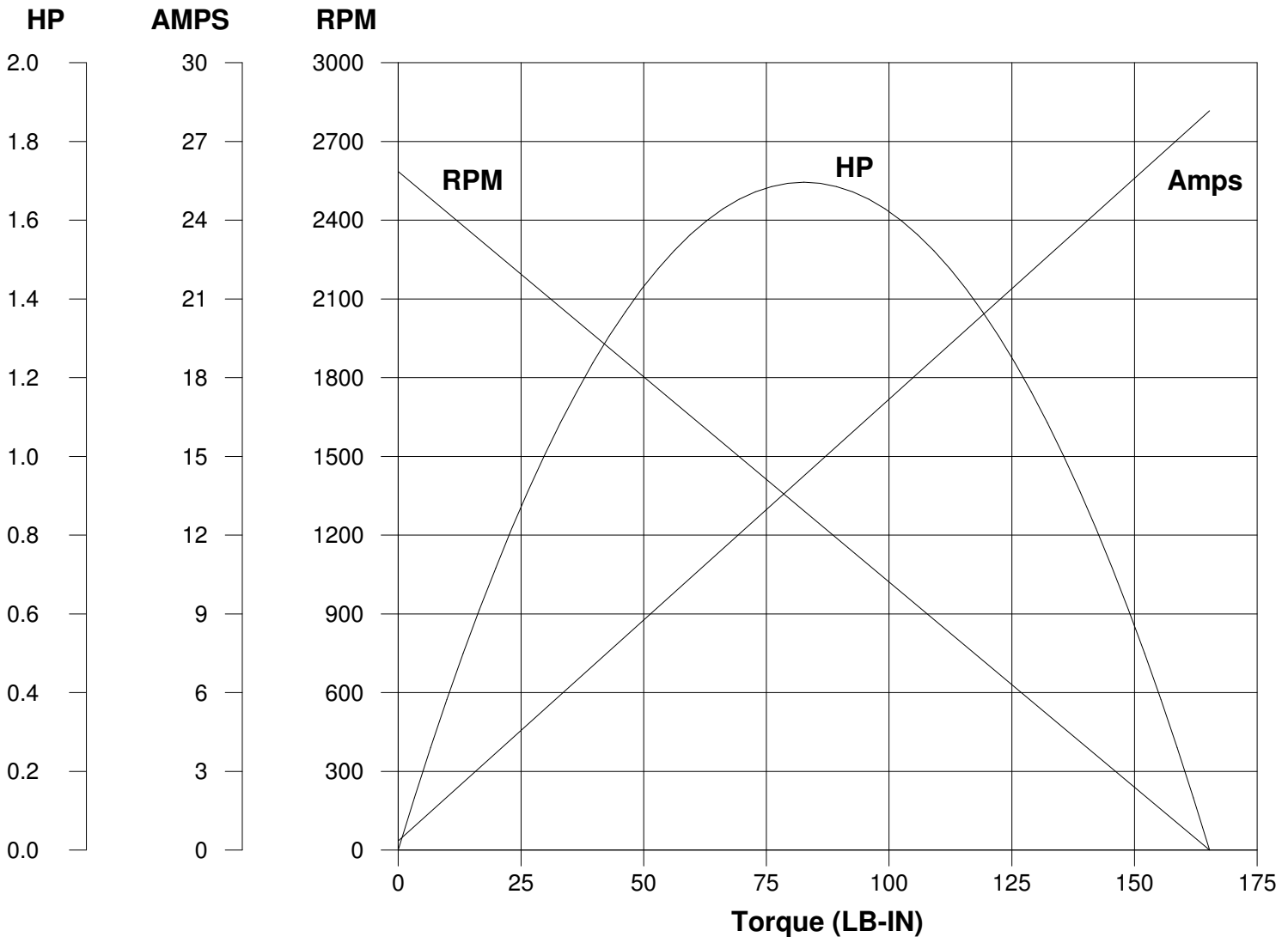

Ra	<u>3.2500</u>	Ohms
La	<u>39.00</u>	mHenrys
Ja	<u>5.625</u>	LB-IN ²
Ke	<u>69.31</u>	V/KRPM

Kt	<u>5.858</u>	LB-IN/AMP
Imax	<u>31.2</u>	AMPS Allowed
FL Torque	<u>12.60</u>	LB-IN
FL EFF	<u>80.40</u>	%

Winding W- D47219-1 Prepared by V. Boehlen Date 04-29-2005