

PRODUCT INFORMATION PACKET



Model No: 116641.00

Catalog No: 116641.00

White Duck™ General Purpose Motor, 0.33 & 0.25 HP, 3 Ph, 60 & 50 Hz, 230/460 & 190/380 V,
3600 & 3000 RPM, 56C Frame, TENV

Operational at 208-230/460 V @60HZ



Regal and LEESON are trademarks of Regal Rexnord Corporation or one of its affiliated companies.
©2026 Regal Rexnord Corporation, All Rights Reserved. MC017097E





Nameplate Specifications

Phase	3	Output HP	0.33 & 0.25 Hp
Output KW	0.25 & 0.19 kW	Voltage	230/460 & 190/380 V
Speed	3450 & 2850 rpm	Service Factor	1.15 & 1.15
Frame	56C	Enclosure	Totally Enclosed Non Ventilated
Thermal Protection	No Protection	Efficiency	77 & 66 %
Ambient Temperature	40 °C	Frequency	60 & 50 Hz
Current	1.1/.55 & 1/.5 A	Power Factor	75
Duty	Continuous	Insulation Class	F
Design Code	B	KVA Code	L
Drive End Bearing Size	6205	Opp Drive End Bearing Size	6203
UL	Recognized	CSA	Y
CE	N	IP Code	55
Number of Speeds	1		

Technical Specifications

Electrical Type	Squirrel Cage Induction Run	Starting Method	Across The Line
Poles	2	Rotation	Reversible
Resistance Main	50.4 Ohms	Mounting	Round
Motor Orientation	Horizontal	Drive End Bearing	Ball
Opp Drive End Bearing	Ball	Frame Material	Rolled Steel
Shaft Type	NEMA 56	Overall Length	10.08 in
Frame Length	5.00 in	Shaft Diameter	0.625 in
Shaft Extension	1.88 in	Assembly/Box Mounting	F1 ONLY
Connection Drawing	005010.01	Outline Drawing	034907-550

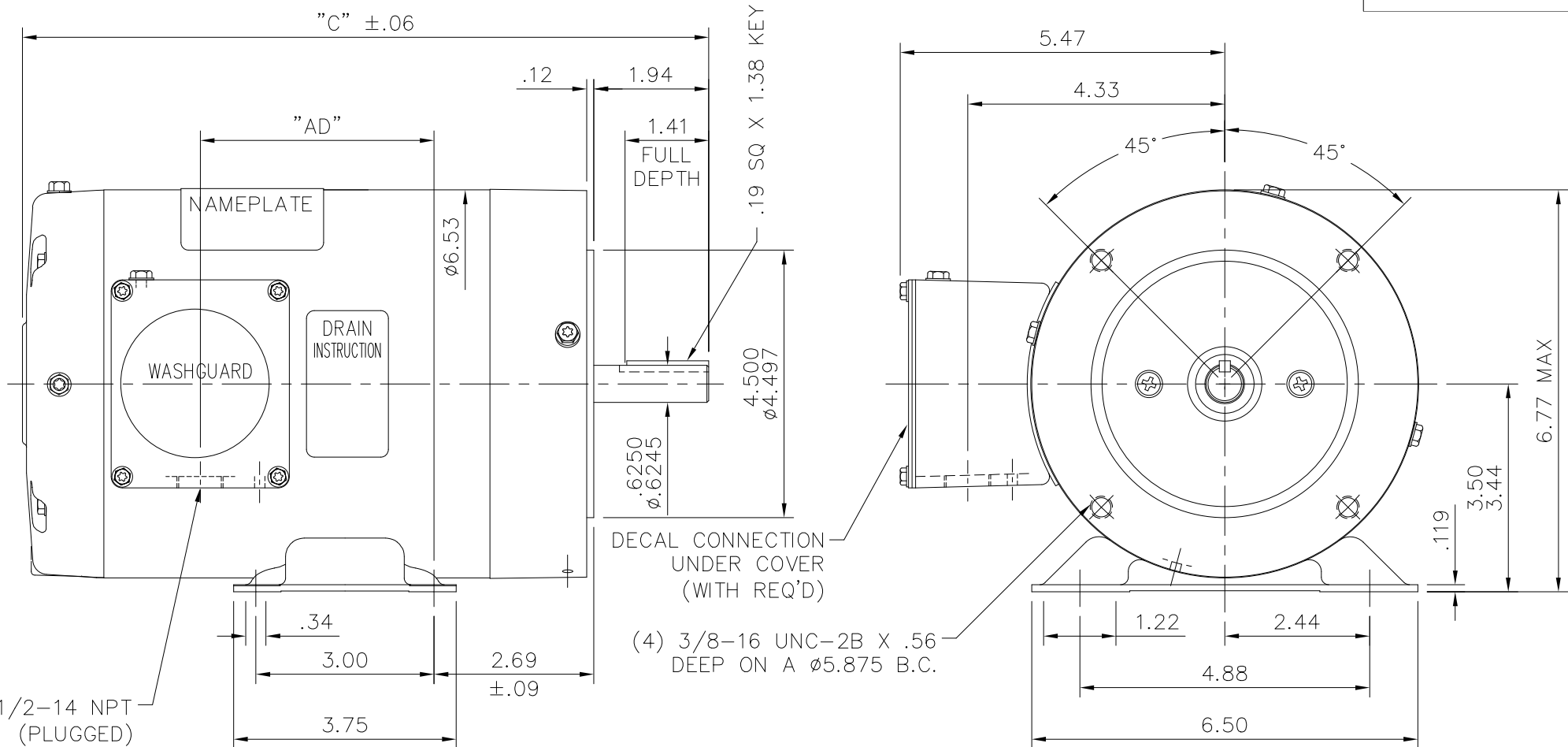

SPECIAL FEATURES:

- 1) SHAFT SEALS & V-RING
- 2) DRAIN HOLES IN BOTH ENDBELLS & CONDUIT BOX
- 3) GASKETS THROUGHOUT
- 4) STAINLESS STEEL SHAFT, HARDWARE & NAMEPLATE

DASH NO.	"C"	"AD"
550	10.08	2.44
600	10.58	2.94
650	11.08	3.44
700	11.58	3.94

MAXIMUM FACE RUNOUT .004 T.I.R.
 MAXIMUM PILOT ECCENTRICITY .004 T.I.R.
 PERMISSIBLE SHAFT RUNOUT .002 T.I.R.

			TOLERANCES UNLESS SPECIFIED		REGAL BELOIT	REGAL-BELOIT CORPORATION	DRAWN		
			DEC.	INCHES			RDW		
04	UPDATED DASH NO AS PER ECR	GKB 03/16/26	BAN	.X	±.1		CHK		
03	SHAFT END E.B. WAS 021255-19 PER ECO 04-1702	LST 9/17/04		.XX	±.03	TITLE	APPD KMM 12/12/01		
02	REVISED OUTLINE TO CURRENT STNDS	RDW 2/11/03	SW	.XXX	±.005	OUTLINE - 56 FRAME	SCALE 3=8		
01	L.E. ENDBELL WAS 021209.27	KMM 8/19/02		.XXXX	±.0005	TENV - RIGID "C"	REF 033694		
NO.	REVISION	BY & DATE	CHK	ANG	±1/2"	MAT'L.	FMF		
			RFP		1/29/05	FINISH	PREV		
THIS DRAWING IN DESIGN AND DETAIL IS OUR PROPERTY AND MUST NOT BE USED EXCEPT IN CONNECTION WITH OUR WORK ALL RIGHTS OF DESIGN AND INVENTION ARE RESERVED THIS IS AN ELECTRONICALLY GENERATED DOCUMENT - DO NOT SCALE THIS PRINT			DIST			CAD FILE	SIZE	DRAWING NO.	REV.
						034907	A	034907	04

VIEW FROM OUTSIDE OF MOTOR AT SWITCH END.

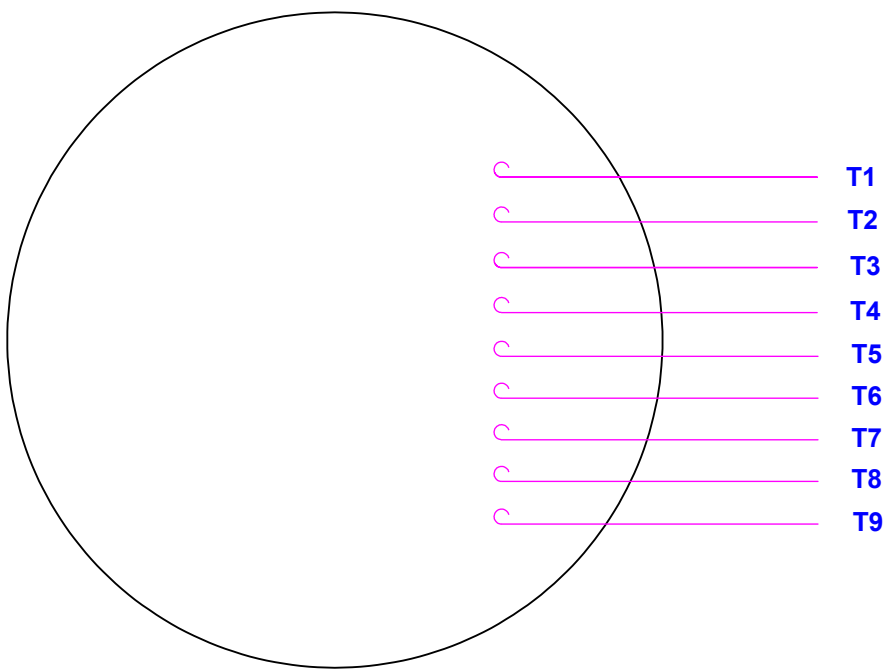

LINE LEADS

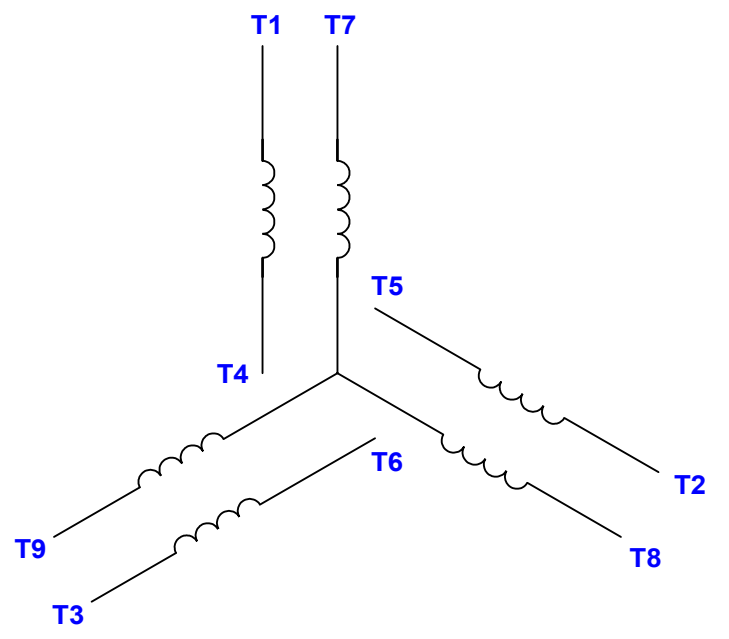

VOLTAGE	L1	L2	L3	JOIN & INSULATE
HIGH	T1	T2	T3	(T4, T7) (T5, T8) (T6, T9)
LOW	T1, T7	T2, T8	T3, T9	T4, T5, T6

RBC PROPRIETARY AND CONFIDENTIAL INFORMATION
 This document is the property of REGAL BELOIT CORPORATION ("RBC") including its subsidiaries and divisions and contains proprietary information of RBC. This document is loaned on the express condition that neither it nor the information contained therein shall be disclosed to others without the express written consent of RBC, and that the information shall be used by the recipient only as approved expressly by RBC. This document shall be returned to RBC upon its request. This document may be subject to certain restrictions under U.S. export control laws and regulations.

				TOLERANCES UNLESS SPECIFIED		DRAWN RDW 04/12/02	
				DEC	INCHES	CHK	
				.X	±.1	APPR	
12	CHG FROM LEESON TO RRX TEMPLATE AS PER ECR-0237142	KVDG 09/19/24	DS	.XX	±.01	TITLE EXTERNAL WIRING DIAGRAM	
--	REDRAWN IN SOLIDWORKS	VJB 02/08/11		.XXX	±.005	3 PHASE W/O PROTECTOR	
11	ADD REV TO MATCH ORACLE	KJH 06/08/09	MDN	.XXX	±.0005	MAT'L DECAL - 004014	
NO	REVISION	BY & DATE	CHK	ANG	±1/2°	FINISH	
			RFP	04/12/02	PREV	SIZE	DRAWING NO
THIRD ANGLE PROJECTION			NETWORK FILE NAME		00501001	A	005010-01
							REV
							12





**1051 CHEYENNE AVE.
GRAFTON, WI 53024
PH. 262-377-8810**

CERTIFICATION DATA SHEET

CATALOG #: 116641.00

CONN. DIAGRAM: 005010.01

OUTLINE: 034907-500

MOUNTING: F1 ONLY

WINDING #: T632186 FR 3 C

TYPICAL MOTOR PERFORMANCE DATA

HP	kW	SYNC. RPM	F.L. RPM	FRAME	ENCLOSURE	KVA CODE	DESIGN
1/3&1/4	0.25&0.19	3600	3450&2850	56C	TENV	L	B

PH	Hz	VOLTS	AMPS	START TYPE	DUTY	INSL	S.F.	AMB°C
3	60/50	208-230/460&190/380	1.1/.55&1/.5	ACROSS THE LINE	CONTINUOUS	F4	1.15/1.15	40

FULL LOAD EFF:	77&66	3/4 LOAD EFF:	86.4	1/2 LOAD EFF:	77.2	GTD. EFF		ELEC. TYPE	
FULL LOAD PF:	75&70.7	3/4 LOAD PF:	69	1/2 LOAD PF:	49.9	0		SQ CAGE IND RUN	

F.L. TORQUE	LOCKED ROTOR AMPS	L.R. TORQUE	B.D. TORQUE	F.L. RISE°C
8 OZ-FT	8.8 / 4.4	24.36 OZ-FT 325 %	35.3 OZ-FT 450 %	77

SOUND PRESSURE @ 3 FT.	SOUND POWER	ROTOR WK^2	MAX. WK^2	SAFE STALL TIME	STARTS / HOUR	APPROX. MOTOR WGT
0 dBA	10 dBA	0.032 LB-FT^2	0 LB-FT^2	10 SEC.	0	- LBS.

***** SUPPLEMENTAL INFORMATION *****

DE BRACKET TYPE	ODE BRACKET TYPE	MOUNT TYPE	ORIENTATION	SEVERE DUTY	HAZARDOUS LOCATION	DRIP COVER	SCREENS	PAINT
C-FACE	STANDARD	ROUND	HORIZONTAL	FALSE	NONE	FALSE	NONE	WHITE - LEESON (EPOXY)

BEARINGS		GREASE	SHAFT TYPE	SPECIAL DE	SPECIAL ODE	SHAFT MATERIAL	FRAME MATERIAL
DE	ODE						
BALL	BALL	POLYREX EM	STANDARD 56	NONE	NONE	303 STAINLESS (C-501)	ROLLED STEEL
6205	6203						

THERMO-PROTECTORS				THERMISTORS	CONTROL	SPACE HEATERS
THERMOSTATS	PROTECTORS	WDG RTDs	BRG RTDs			
NONE	NOT	NONE	NONE	NONE	FALSE	NONE VOLTS

*
N
O
T
E
S

INVERTER TORQUE: NONE
INV. HP SPEED RANGE: NONE
ENCODER: NONE
NONE NONE
NONE NONE PPR
BRAKE: NONE NONE
NONE P/N NONE
NONE NONE
NONE FT-LB NONE V NONE Hz

Data Sheet

Date: 1/17/2018

116641.00



Data @ **460 V**

Motor Load Data

Load	0%	25%	50%	75%	100%	115%	125%	LR
Current (Amps)	0.34	0.36	0.41	0.46	0.54	0.58	0.62	4.4
Torque (ft-lb)	0.00	31.9	64.6	113	129	2,370	163	394
RPM	3600	3571	3550	3531	3506	3,497	3483	0
Efficiency (%)		53.9	77.2	86.4	77.1	78.0	78.9	
P.F. (%)	18.5	40.4	49.9	69.0	75.1	77.7	80.2	0.0

Motor Speed Data

	LR	Pull-Up	BD	Rated	Idle
Speed (RPM)	0	229	2600	3506	3600
Current (Amps)	4.4	4.3	2.90	0.54	0.34
Torque (ft-lb)	394	386	571	129	0.00

Information Block				
HP	0.3			
Sync. RPM	3600			
Frame	140			
Enclosure	TEFC			
Construction	NA			
Voltage	208-230/460#190/380 V			
Frequency	60 Hz			
Design	B			
LR Code letter	L			
Service Factor	1.15			
Temp Rise @ FL	45 °C			
Duty	CONT			
Ambient	40 °C			
Elevation	1,000 feet			
Rotor/Shaft wk ²	0.03 Lb-Ft ²			
Ref Wdg	T632186 FR			
Sound Pressure @ 1M	0 dBA			
VFD Rating	NONE			
Outline Dwg	034907-500			
Conn. Diag	005010.01			
Additional Specifications:				
0				
0				
EQUIV CKT (OHMS / PHASE)				
R1	R2	X1	X2	Xm
0.0000	0.0000	0.0000	0.0000	0.0000

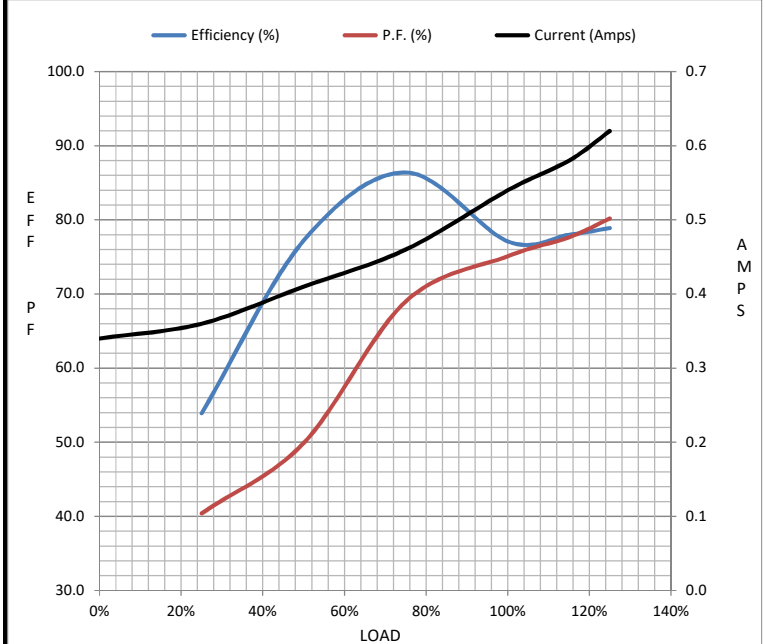

Speed - Torque Curve

