

PRODUCT INFORMATION PACKET



Model No: 145THTN8043
Catalog No: Y987
Brake Motor, 2 HP, 3 Ph, 60 Hz, 230/460 V, 1800 RPM, 145TC Frame, TENV



Regal and LEESON are trademarks of Regal Rexnord Corporation or one of its affiliated companies.
©2025 Regal Rexnord Corporation, All Rights Reserved. MC017097E





Nameplate Specifications

Phase	3	Output HP	2 Hp
Output KW	1.5 kW	Voltage	230/460 V
Speed	1750 rpm	Service Factor	1.0
Frame	145TC	Enclosure	Totally Enclosed Non Ventilated
Thermal Protection	Thermostat	Efficiency	85.5 %
Ambient Temperature	40 °C	Frequency	60 Hz
Current	6.0/3.0 A	Power Factor	78
Duty	Continuous	Insulation Class	F
Design Code	INV	KVA Code	M
Drive End Bearing Size	6205	Opp Drive End Bearing Size	6205
UL	Recognized	CSA	Y
CE	Y	IP Code	43
Number of Speeds	1		

Technical Specifications

Electrical Type	Squirrel Cage Inverter Duty	Starting Method	Inverter Only
Poles	4	Rotation	Reversible
Resistance Main	6.48 Ohms	Mounting	Rigid Base
Motor Orientation	Horizontal	Drive End Bearing	Ball
Opp Drive End Bearing	Ball	Frame Material	Cast Iron
Shaft Type	T	Overall Length	18.00 in
Frame Length	6.25 in	Shaft Diameter	0.875 in
Shaft Extension	2.12 in	Assembly/Box Mounting	F1/F2 CAPABLE
Inverter Load	CONSTANT 2000:1		
Outline Drawing	104965-625	Connection Drawing	EE7308T

4

3

2

1

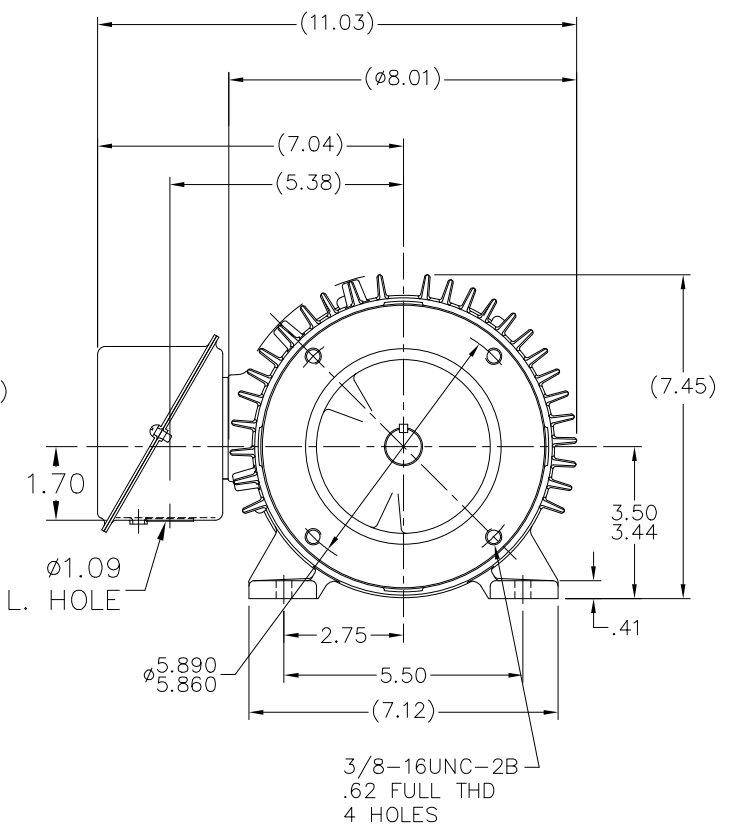
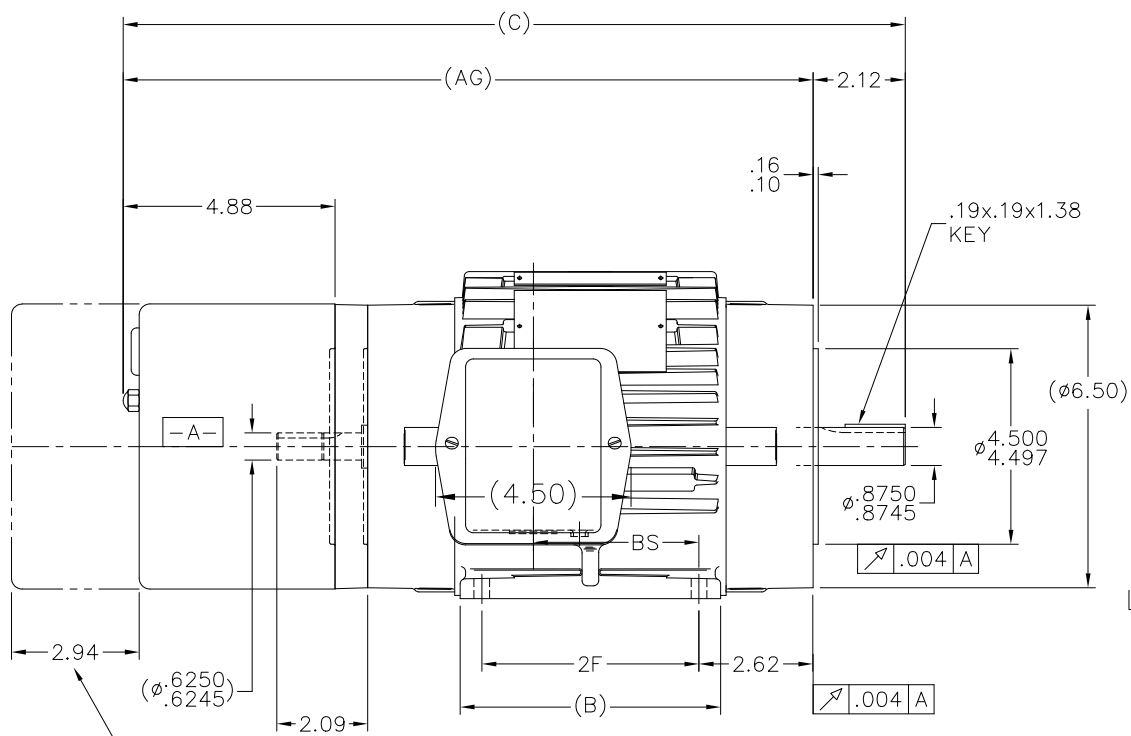

- NOTES:
 1- BOX CAN BE ROTATED IN 90° STEPS.
 2- BOX CAN BE MOUNTED ON OPPOSITE SIDE BY REMOVING BRACKETS AND TURNING FRAME 180°.
 3- NAMEPLATE READ FROM CONDUIT BOX SIDE.

525	143T	17.00	14.88	5.00	4.00	2.81	
625	145T	18.00	15.88	6.00	5.00	3.81	
DASH	FRAME	C	AG	B	2F	BS	

DRAWING REVISION 06	REVISION BY KVDG	REV DATE/ DATE 05/20/2025
REQUEST NUMBER ECR-0242944	APPROVED BY DS	DATE 05/20/2025
REQUEST NUMBER DESCRIPTION UPDATED THE DRAWING TO RRX TEMPLATE.		
<small>COPYRIGHT (PER REVISION DATE) REGAL BELOIT AMERICA, INC. ALL RIGHTS RESERVED. PROPRIETARY AND CONFIDENTIAL INFORMATION - THIS DOCUMENT IS THE PROPERTY OF REGAL BELOIT AMERICA, INC. (OWNER) AND CONTAINS OWNER'S PROPRIETARY INFORMATION. ANY PERSON, CORPORATION OR OTHER FIRM RECEIVING IT IS DEEMED, BY RECEIVING IT, TO AGREE THAT IT, AND/OR ANY PART OF IT, SHALL NOT BE DISCLOSED TO ANY PERSON, CORPORATION OR OTHER ENTITY, DUPLICATED, AND/OR USED, EXCEPT AS EXPRESSLY APPROVED IN WRITING IN ADVANCE BY OWNER. THIS DOCUMENT SHALL BE RETURNED TO OWNER UPON REQUEST. IT MAY BE SUBJECT TO CERTAIN RESTRICTIONS UNDER APPLICABLE EXPORT CONTROL LAWS AND REGULATIONS.</small>		

TOLERANCES (EXCEPT AS NOTED):
 DEC. INCH mm ANGLE
 .X ±0.1 [±3] ±0.5°
 .XX ±0.01 [±0.3]
 .XXX ±0.005 [±0.13]
 .XXXX ±0.0005 [±0.013]
 REMOVE BURRS & BREAK SHARP
 EDGES: .003/.015 [.08/.38] X 45
 CORNER FILLETS: R.02 [.5]
 MACHINED SURFACES: 125/ 3.2/
 INCH mm
 mm DIMENSIONS IN [BRACKETS]
 ARE FOR REFERENCE ONLY

DRAWN BY DRS
DATE 05/24/2001
APPROVED BY GK
DATE 06/19/2001
REFERENCE
THIRD ANGLE PROJECTION

Regal Beloit America, Inc.	
DESCRIPTION OUTLINE - C' FACE - TS - TENV 140T FR. - BRAKE & PROVISIONS FOR TACH.	
MAT'L	PROCESS/FINISH
SIZE B	DRAWING NUMBER 104965
	SHEET 1 OF 1

4

3

2

1

HIGH VOLTAGE

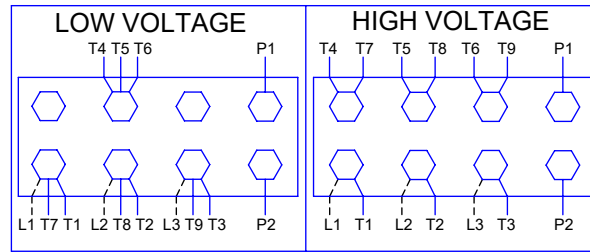

**THREE PHASE
DUAL VOLTAGE MOTOR**

THERMO-PROTECTORS
CONNECTED IN SERIES



NOTE FOR FACTORY USE ONLY:
TO SURGE TEST FOR COMMON CONNECT:
HIGH VOLT: CONNECT P1 TO T1
THEN P2 TO L1
LOW VOLT: CONNECT P1 TO T1 & T7,
THEN P2 TO L1

LOW VOLTAGE

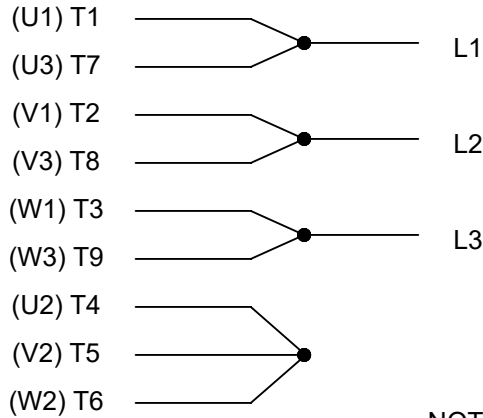

VIEW OF TERMINAL END

NOTE: LEAD'S COLOR CAN BE YELLOW OR WHITE FOR MT2 PLANT

DRAWING REVISION T	REVISION BY ZR	DATE 01-14-2019		DRAWN BY SMC	Regal Beloit America, Inc.
ECO ECO-0159915	APPROVED BY DR	DATE 01-15-2019		DATE 05-13-1992	
ECO DESCRIPTION ADDED TERMINAL CONNECTION DIAGRAM				APPROVED BY TB	DESCRIPTION CONN DIAGRAM-INTERNAL 3 PHASE - DUAL VOLTAGE MOTOR
<small>COPYRIGHT REGAL BELOIT AMERICA, INC. ALL RIGHTS RESERVED. PROPRIETARY AND CONFIDENTIAL INFORMATION - THIS DOCUMENT IS THE PROPERTY OF REGAL BELOIT AMERICA, INC. ("OWNER") AND CONTAINS OWNER'S PROPRIETARY INFORMATION. ANY PERSON, CORPORATION OR OTHER FIRM RECEIVING IT IS DEEMED, BY RECEIVING IT, TO AGREE THAT IT, AND/OR ANY PART OF IT, SHALL NOT BE DISCLOSED TO ANY PERSON, CORPORATION OR OTHER ENTITY, DUPLICATED, AND/OR USED, EXCEPT AS EXPRESSLY APPROVED IN WRITING IN ADVANCE BY OWNER. THIS DOCUMENT SHALL BE RETURNED TO OWNER UPON REQUEST. IT MAY BE SUBJECT TO CERTAIN RESTRICTIONS UNDER APPLICABLE EXPORT CONTROL LAWS AND REGULATIONS.</small>			DATE 05-13-1992	MATERIAL	PROCESS/FINISH
			REFERENCE EE7308/EE7300	THIRD ANGLE PROJECTION	SIZE A

CERTIFICATION DATA SHEET

Model#: 145THTN8043 AA WINDING#: ZT490 F 3
 CONN. DIAGRAM: A-EE7308T ASSEMBLY: F1/F2 CAPABLE
 OUTLINE: A-104965-625

TYPICAL MOTOR PERFORMANCE DATA

HP	KW	SYNC. RPM	F.L. RPM	FRAME	ENCLOSURE	KVA CODE	DESIGN
2	1.49	1800	1750	145TC	TENV	M	INV

PH	Hz	VOLTS	FL AMPS	START TYPE	DUTY	INSL	S.F	AMB°C	ELEVATION
3	60	230/460	6/3	INVERTER ONLY	CONTINUOUS	F3	1.0	40	3300

FULL LOAD EFF: 85.5	3/4 LOAD EFF: 84	1/2 LOAD EFF: 82	GTD. EFF	ELEC. TYPE	NO LOAD AMPS
FULL LOAD PF: 78	3/4 LOAD PF: 66	1/2 LOAD PF: 53.5	82.5	SQ CAGE INV DUTY	3.4 / 1.7

F.L. TORQUE	LOCKED ROTOR AMPS	L.R. TORQUE	B.D. TORQUE	F.L. RISE°C
6 LB-FT	50 / 25	21.8 LB-FT 363	28.5 LB-FT 475	85

SOUND PRESSURE @ 3 FT.	SOUND POWER	ROTOR WK^2	MAX. WK^2	SAFE STALL TIME	STARTS / HOUR	APPROX. MOTOR WGT
62 dBA	72 dBA	0.13 LB-FT^2	0 LB-FT^2	0 SEC.	0	83 LBS.

EQUIVALENT WYE CKT.PARAMETERS (OHMS PER PHASE)

R1	R2	X1	X2	XM
3.834	2.8968	5.9498	5.6374	154.78

RM	ZREF	XR	TD	TD0
6560.4	142	1.6	0.0061	0.147

*** SUPPLEMENTAL INFORMATION ***

DE BRACKET TYPE	ODE BRACKET TYPE	MOUNT TYPE	ORIENTATION	SEVERE DUTY	HAZARDOUS LOCATION	DRIP COVER	SCREENS	PAINT
C-FACE	BRAKE AND ENCODER	RIGID	HORIZONTAL	FALSE	NONE	FALSE	NONE	BLUE (POWDER)

BEARINGS		GREASE	SHAFT TYPE	SPECIAL DE	SPECIAL ODE	SHAFT MATERIAL	FRAME MATERIAL
DE	OPE						
BALL	BALL	POLYREX EM	T	NONE	NONE	1144 STRESSPROOF (C-223)	CAST IRON
6205	6205						

THERMO-PROTECTORS				THERMISTORS	CONTROL	SPACE /n HEATERS
THERMOSTATS	PROTECTORS	WDG RTDs	BRG RTDs			
TSTATS (N/C)	NOT	NONE	NONE	NONE	FALSE	NONE VOLTS

If Inverter equals NONE, contact factory for further information

* N O T E S *	INVERTER TORQUE: CONSTANT 2000:1
	INV. HP SPEED RANGE: 2.0 X BASE SPEED
	ENCODER: PROVISIONS ONLY
	NONE NONE NONE NONE PPR
BRAKE: REGAL SUPPLIED AND MOUNT	

NONE	
STEARNS	P/N 91697-10A1KB
56,000	NEMA 2
10 FT-LB	208-230/460-190/380 V
60/50 Hz	

DATE: 06/23/2017 02:00:24 AM
FORM 3531 REV.3 02/07/99
** Subject to change without notice.

Data Sheet

Date: 19-06-2017
 Customer: _____
 Attention: _____
 Submitted by: FAREEDA DUDEKULA



145THTN8043

Submittal

Data @ 460 V

Motor Load Data

Load	0%	25%	50%	75%	100%	115%	125%	LR
Current (Amps)	1.70	1.90	2.10	2.50	3.0	3.3	3.5	25.0
Torque (ft-lb)	0.00	1.50	3.0	4.5	6.0	6.8	7.5	21.8
RPM	1800	1788	1776	1765	1750	1,746	1740	0
Efficiency (%)		73.5	82.0	84.0	85.5	85.3	85.0	
P.F. (%)	7.8	34.5	53.5	66.0	78.0	79.5	81.0	65.0

Motor Speed Data

	LR	Pull-Up	BD	Rated	Idle
Speed (RPM)	0	900	1500	1750	1800
Current (Amps)	25.0	22.5	18.5	3.0	1.70
Torque (ft-lb)	21.8	19.5	28.5	6.0	0.00

Information Block				
HP	2.0			
Sync. RPM	1800			
Frame	145			
Enclosure	TENV			
Construction	TTN			
Voltage	230/460 V			
Frequency	60 Hz			
Design	B			
LR Code letter	M			
Service Factor	1.0			
Temp Rise @ FL	90 ° C			
Duty	CONT			
Ambient	40 ° C			
Elevation	1,000 feet			
Rotor/Shaft wk ²	0.13 Lb-Ft ²			
Ref Wdg	ZT490 F			
Sound Pressure @ 1M	62 dBA			
VFD Rating	CONSTANT 2000:1			
Outline Dwg	A-104965-625			
Conn. Diag	A-EE7308T			
Additional Specifications:				
0				
365THFS8036				
EQUIV CKT (OHMS / PHASE)				
R1	R2	X1	X2	Xm
3.8340	2.8970	5.9500	5.6370	154.7800

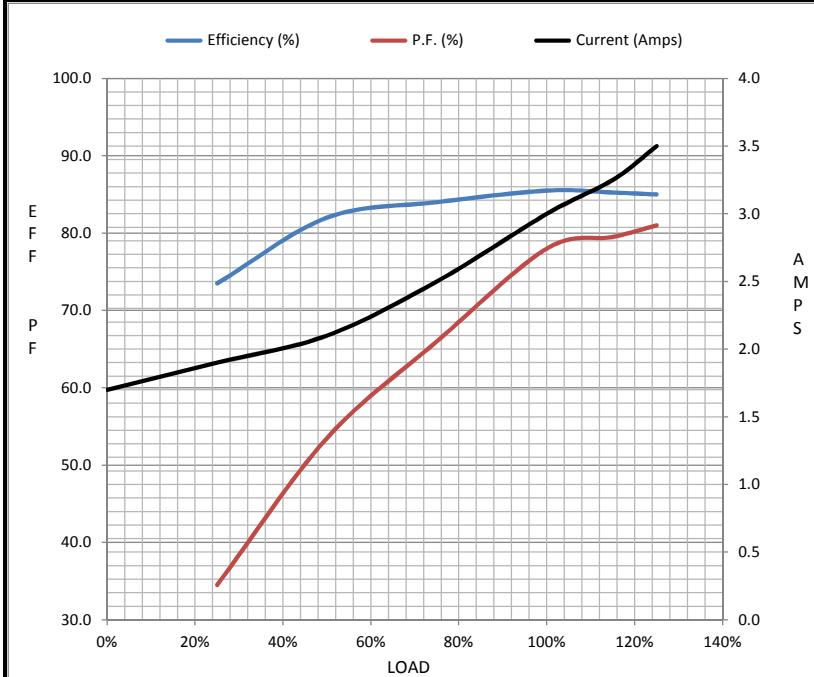

Speed - Torque Curve

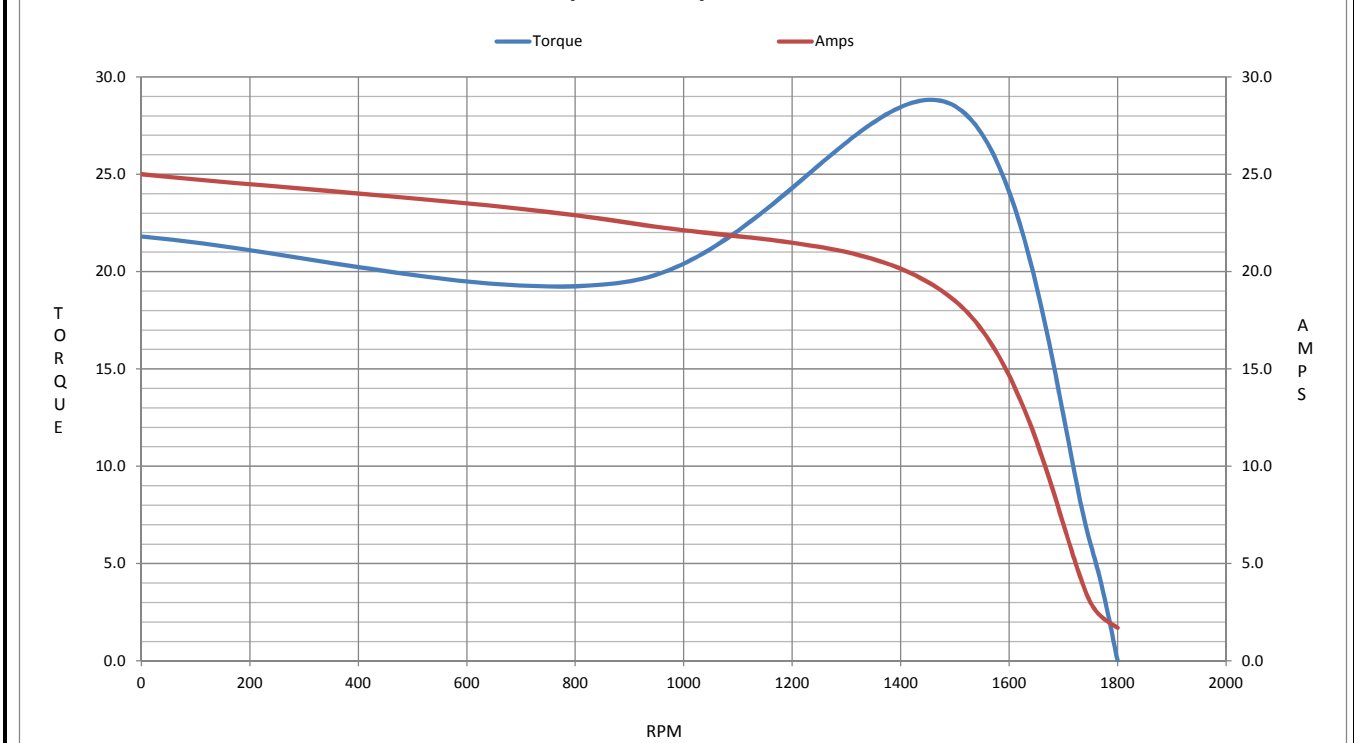

EC Declaration of Conformity

The undersigned representing
the manufacturer:

Regal Beloit America
1946 West Cook Road
Fort Wayne, IN 46818

and the authorized representative
established within the Community:

Regal Beloit Italy
Via Modena, 18
24040 Ciserano(BG) - Italy

are committed to providing customers with products that comply with applicable regulations and international protocols to which they are subject, including the requirements of the European Parliament Directive on the Harmonization of the laws relating to electrical equipment designed for use within certain voltage limits (2014/35/EU).

Regal Beloit America declares that the following product(s), to which this declaration relates, are in conformity with the relevant sections of the EC standards listed below.

This statement supersedes any statements previously issued pertaining to the product(s) listed below and is subject to change without notice.

Model No : 145THTN8043

(Model No. may contain prefix and/or suffix characters)

Catalog No : Y987

Rework No : N/A

Directives :

Low Voltage Directive 2014/35/EU

Harmonized Standards Used :

EN 60034-1: 2010 (IEC 60034-1: 2010)

EN 60034-5: 2001/A1:2007 (IEC 60034-5: 2000/A1:2006)

Authorized Representative:



Zach Stauffer
Vice President, Engineering

Authorized Representative in the Community:



Stefano Casiraghi
Technology Director, Engineering

Created on 07/08/2025

CE 25