

PRODUCT INFORMATION PACKET



Model No: 258
Catalog No: 258
50 WATT Refrigeration Motor, 1500 RPM, 115 Volts, Unit Bearing, TEAO



Regal and Century are trademarks of Regal Rexnord Corporation or one of its affiliated companies.
©2022 Regal Rexnord Corporation, All Rights Reserved. MC017097E





Nameplate Specifications

Output Watts	50 W	Frequency	60 Hz
Voltage	115 V	Current	1.7 A
Speed	1500 rpm	Service Factor	1
Phase	1	Duty	Continuous
Insulation Class	A	Frame	UNIT BEARING
Enclosure	Totally Enclosed Air Over	Thermal Protection	Thermally Protected
Ambient Temperature	40 °C	UL	Recognized
CSA	Y	CE	N
Number of Speeds	1		

Technical Specifications

Electrical Type	Shaded Pole	Starting Method	Across The Line
Poles	4	Rotation	Clockwise Lead End
Mounting	2 BOSS/OSE 3 HOLES	Drive End Bearing	Unit
Opp Drive End Bearing	Unit	Frame Material	Cast Iron
Shaft Type	Flat	Frame Length	4.79 in
Shaft Diameter	0.375 in	Shaft Extension	1.6 in
Outline Drawing	258-S01		

This is an uncontrolled document once printed or downloaded and is subject to change without notice. Date Created:11/29/2022

REV	ECO	REV BY	DATE	APPD	DATE
H	0025432	O. CARVAJAL	04-16-2012	D. BALDERRAMA	04-16-2012

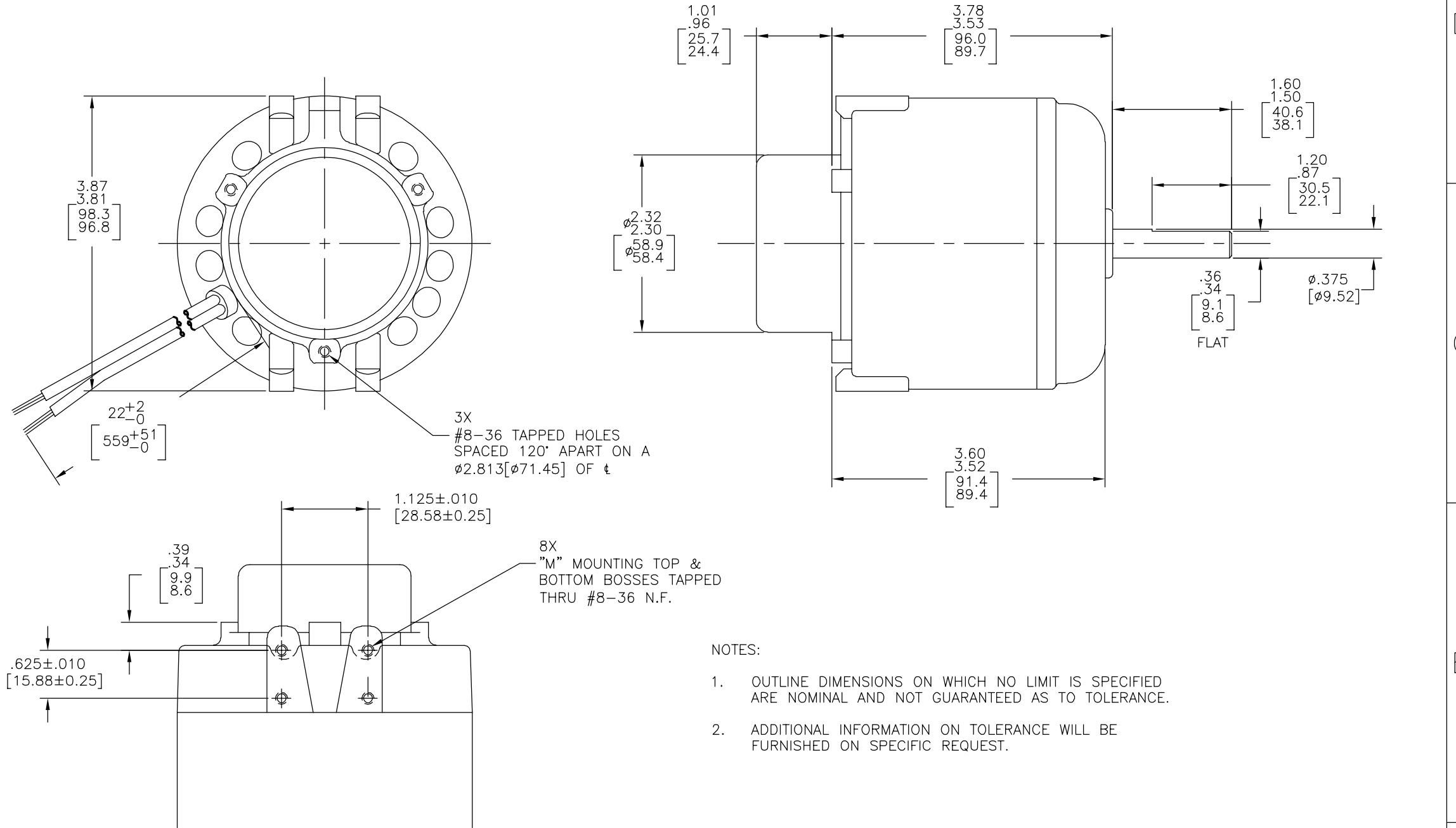

- NOTES:
1. OUTLINE DIMENSIONS ON WHICH NO LIMIT IS SPECIFIED ARE NOMINAL AND NOT GUARANTEED AS TO TOLERANCE.
 2. ADDITIONAL INFORMATION ON TOLERANCE WILL BE FURNISHED ON SPECIFIC REQUEST.

ESP-OL50EM1
115V 60HZ CW
CUST NO. 258

<p>GEOMETRIC CHARACTERISTICS & SYMBOLS</p> <ul style="list-style-type: none"> □ FLATNESS — STRAIGHTNESS ∠ ANGULARITY ⊥ PERPENDICULARITY (SQUARENESS) // PARALLELISM ○ ROUNDNESS (CIRCULARITY) ⊘ CYLINDRICITY △ PROFILE OF ANY SURFACE ∩ PROFILE OF ANY LINE ↗ RUNOUT ⊕ TRUE POSITION ◎ CONCENTRICITY ≡ SYMMETRY <p>ASME Y14.5M 1994</p>	<p>UNLESS OTHERWISE SPECIFIED DIM. TOLERANCES ARE AS FOLLOWS:</p> <p>INCH X XX XXX XXXX mm ±0.5 ±0.13 ±0.013</p> <p>ANG. ±50 DEG</p> <p>REMOVE BURRS & BREAK SHARP EDGES: INCH .003-.015 mm 0.1-0.4</p> <p>CORNER FILLETS TO: INCH .020 mm 0.5</p> <p>MACHINE SURFACES: INCH 125 mm 3.2</p> <p>METRIC DIMS. SHOWN IN [BRACKETS]</p>	DR BY: J. NICHTER	03-24-1993		
		APPD:			DESCRIPTION OUTLINE
		THIRD ANGLE PROJECTION	EDS DATE 11-11-2011 FORMAT REV G	SIZE C	DWG NO 258
		CONFIDENTIAL: THIS DRAWING AND ITS INFORMATION ARE THE EXCLUSIVE AND CONFIDENTIAL PROPERTY OF REGAL-BELOIT CORPORATION AND ARE NOT TO BE DISCLOSED, DUPLICATED, DISTRIBUTED OR OTHERWISE USED WITHOUT THE WRITTEN CONSENT OF REGAL-BELOIT CORPORATION. -ALL RIGHTS RESERVED.		SCALE NONE	SHEET 1

REVISION:	ECO	REVISADO POR:	FECHA:	APROBADO POR:	FECHA:
H	0025432	O. CARVAJAL	04-16-2012	D. BALDERRAMA	04-16-2012

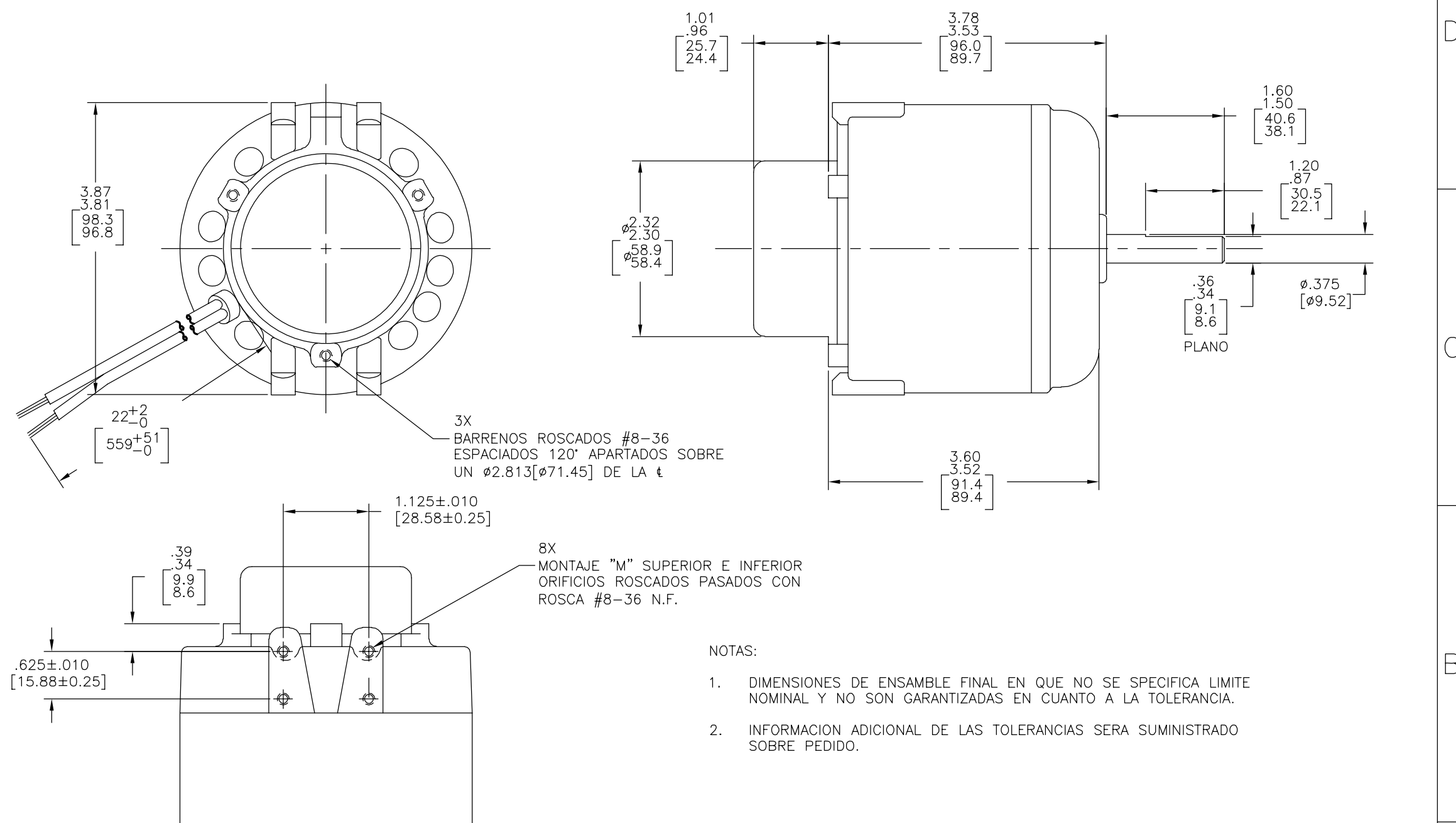

ESP-OL50EM1
115V 60HZ CW
NUMERO DE
CLIENTE 258

CARACTERISTICAS DE GEOMETRIA Y SIMBOLOS ▽ PLANICIDAD — RECTITUD ∠ ANGULARIDAD ⊥ PERPENDICULARIDAD (A ESCUADRA) // PARALELISMO ○ REDONDEZ (CIRCULARIDAD) ∅ CILINDRICIDAD △ PERFIL DE CUALQUIER SUPERFICIE ▲ PERFIL DE CUALQUIER LINEA ↗ VARIACION ⊕ POSICION REAL ⊙ CONCENTRICIDAD = SIMETRIA	A MENOS QUE SE ESPECIFIQUE DE OTRA MANERA, LAS TOLERANCIAS DE LAS DIMS; SON LAS SIGUIENTES: PULG ±.1 ±.02 ±.005 ±.0005 mm ±0.5 ±0.13 ±0.013 ANG. ±50 GRADOS ELIMINAR REBABAS Y ORILLAS FILOSAS DEL BORDE. PULG .003-.015 mm 0.1-0.4 FILETEAR ESQUINA: PULG .020 mm 0.5 MAQUINAR SUPERFICIES PULG 125 mm 3.2 DIMS METRICAS MOSTRADAS [PARENTESIS]	DIBUJADO POR: J. NICTER	03-24-1993	DESCRIPCION: OUTLINE
		APROBADO POR:		
CONFIDENCIAL: ESTE DIBUJO Y SU INFORMACION SON PROPIEDAD DE USO EXCLUSIVO Y CONFIDENCIAL DE REGAL-BELOIT CORPORATION. Y NO DEBERAN SER REVELADOS, DUPLICADOS, DISTRIBUIDOS O USARSE DE OTRA MANERA SIN EL CONSENTIMIENTO ESCRITO DE REGAL-BELOIT CORPORATION. -TODOS LOS DERECHOS RESERVADOS.				ESCALA: NONE HOJA: 1

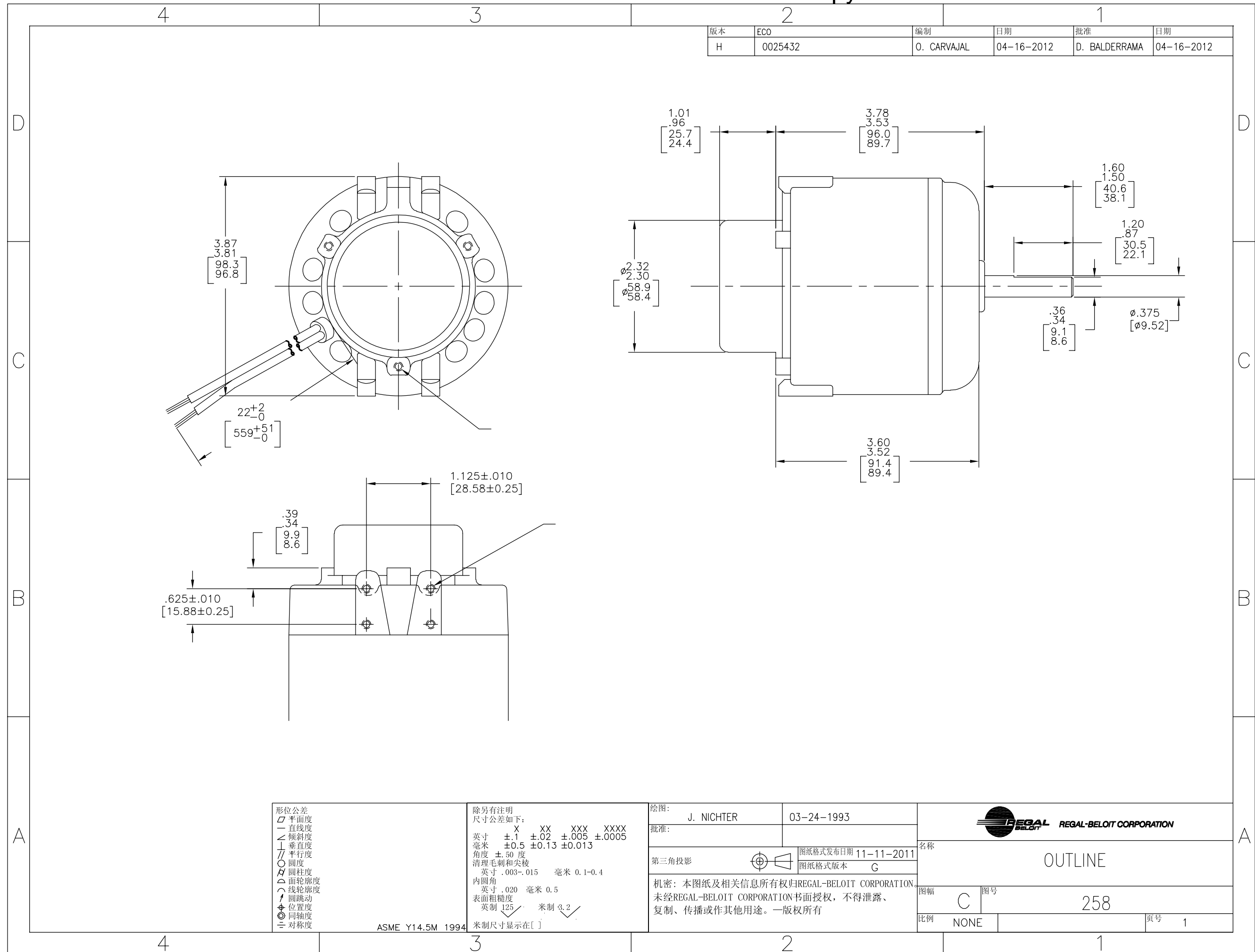

版本	ECO	编制	日期	批准	日期
H	0025432	O. CARVAJAL	04-16-2012	D. BALDERRAMA	04-16-2012

形位公差 □ 平面度 — 直线度 ∠ 倾斜度 ⊥ 垂直度 ∥ 平行度 ○ 圆度 ⊘ 圆柱度 △ 面轮廓度 ⌒ 线轮廓度 ↗ 圆跳动 ⊕ 位置度 ⊙ 同轴度 ≡ 对称度	除另有注明 尺寸公差如下: 英寸 X XX XXX XXXX 毫米 ±.1 ±.02 ±.005 ±.0005 毫米 ±0.5 ±0.13 ±0.013 角度 ±.50 度 清理毛刺和尖棱 英寸 .003-.015 毫米 0.1-0.4 内圆角 英寸 .020 毫米 0.5 表面粗糙度 英制 125 米制 3.2
--	--

绘图:	J. NICHTER	03-24-1993
批准:		
第三角投影		图纸格式发布日期 11-11-2011 图纸格式版本 G
机密: 本图纸及相关信息所有权归REGAL-BELOIT CORPORATION 未经REGAL-BELOIT CORPORATION书面授权, 不得泄露、 复制、传播或作其他用途。—版权所有		

名称	OUTLINE
图幅	C
图号	258
比例	NONE
页号	1

ASME Y14.5M 1994

米制尺寸显示在 []