

PRODUCT INFORMATION PACKET



Model No: 782A

Catalog No: 782A

Condenser Fan Motor, 1/4 HP, 1 Ph, 60 Hz, 460 V, 1625 RPM, 2 Speed, 48 Frame, SEMI ENCL



Regal and Century are trademarks of Regal Rexnord Corporation or one of its affiliated companies.

©2025 Regal Rexnord Corporation, All Rights Reserved. MC017097E





Nameplate Specifications

Phase	1	Output HP	1/4 Hp
Output KW	0.19 kW	Voltage	460 V
Speed	1625 rpm	Service Factor	1.0
Frame	F48Y	Enclosure	Semi Enclosed
Thermal Protection	Automatic	Ambient Temperature	60 °C
Frequency	60 Hz	Current	0.74/0.58 A
Duty	Air Over	Insulation Class	B
UL	Recognized	CSA	Y
CE	N	Number of Speeds	2

Technical Specifications

Electrical Type	Permanent Split Capacitor	Starting Method	Across The Line
Poles	4	Rotation	Reversible
Mounting	Extended Studs	Motor Orientation	Any
Drive End Bearing	Ball	Opp Drive End Bearing	Ball
Frame Material	Rolled Steel	Shaft Type	Double Flat
Overall Length	11.36 in	Frame Length	4.25 in
Shaft Diameter	0.500 in	Shaft Extension	6.06 in
Outline Drawing	F48Z69A01	Connection Drawing	614131-349

This is an uncontrolled document once printed or downloaded and is subject to change without notice. Date Created:02/10/2025

REV	ECO	REV BY	DATE	APPD	DATE
E	0025527	J.AGUILERA	04-24-2012	R.RASCON	04-24-2012

GENERAL INFORMATION:

SHAFT RUNOUT: .001 [.03] T.I.R. PER INCH LENGTH OF EXTENSION

BEARINGS: BALL

MOUNTING POSITION: ALL ANGLE

ELECTRICAL DATA:

OVERLOAD PROTECTOR: AUTOMATIC RESET (T.I. 7AM 036)

LEADS: NO. 18 GA., .06 [1.5] THK. PVC 105°C INSUL.

REVERSING LEADS: NO. 18 GA., .03 [.8] THK. 125' INSUL.

GROUND LEAD: NO. 16 GA., .03 [.8] THK. (GREEN/YELLOW) INSUL.

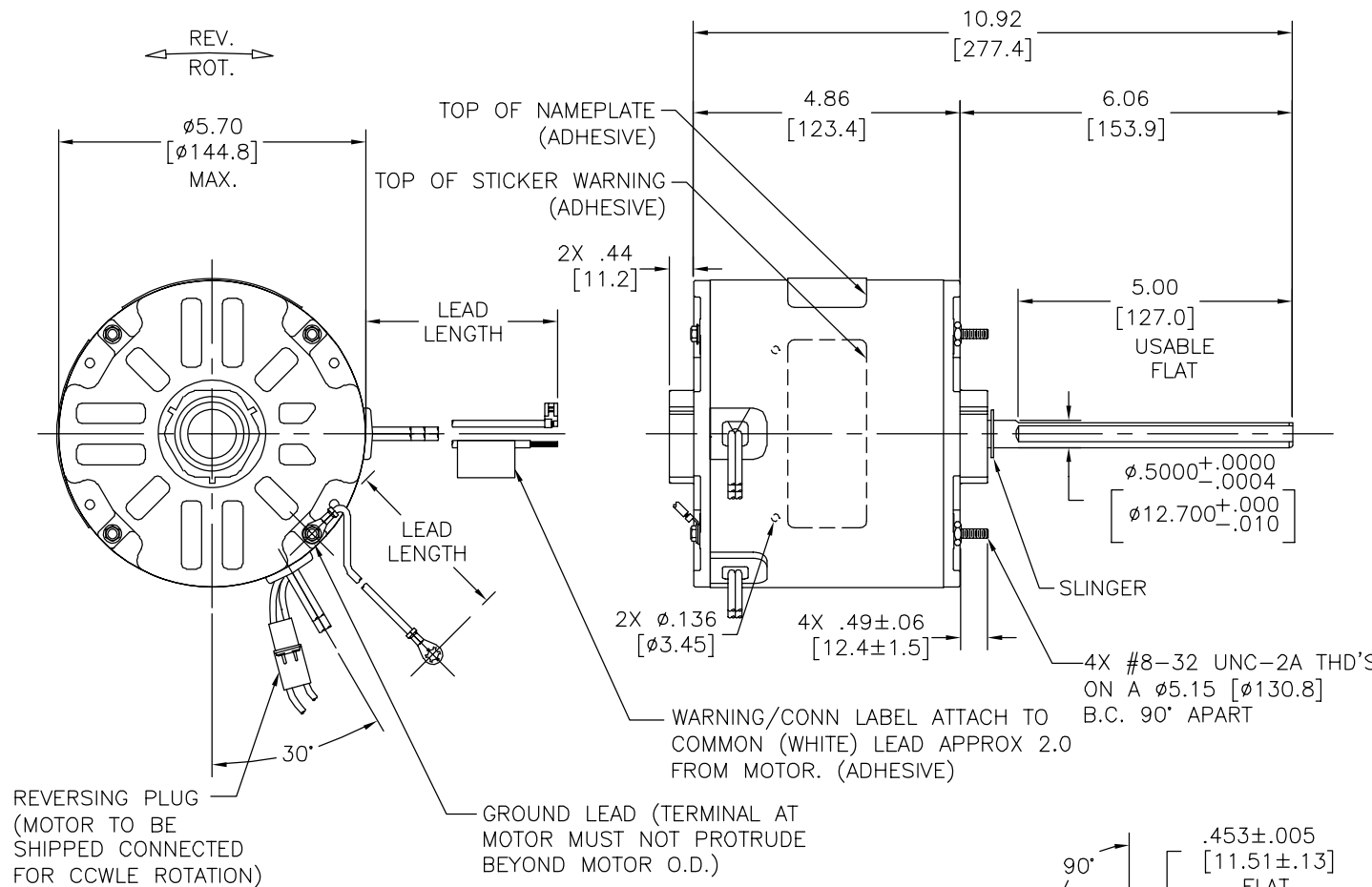

COLOR	LENGTH	TERMINAL OR STRIP LENGTH
GRN/YEL (GRD)	11.0/13.0 [279/330]	#10 EYELET
WHITE/BLACK	4.0/6.0 [102/152]	REVERSING PLUG
BROWN/WHITE	26.0/28.0 [660/711]	.25 [6.4] FLAG
BROWN	26.0/28.0 [660/711]	.25 [6.4] FLAG
RED	26.0/28.0 [660/711]	.50 [12.7] STRIP
PURPLE	26.0/28.0 [660/711]	.50 [12.7] STRIP
BLACK	26.0/28.0 [660/711]	.50 [12.7] STRIP
WHITE	26.0/28.0 [660/711]	.50 [12.7] STRIP

NOTES:
 1 CONDUIT BOX 52P7468-1-E308
 2 COVERS 46P93-1-E308
 1 GASKET 24P75-1
 4 SCREWS 21P258-25
 TO BE SHIPPED SEPARATE IN EACH CARTON WITH MOTOR.

MAIN FRAME - OLE	ENCLOSED
END FRAME - OLE	ENCLOSED
MAIN FRAME - LE	ENCLOSED
END FRAME - LE	OPEN

CUSTOMER	DISTRIBUTION SERVICES
----------	-----------------------

NAMEPLATE DATA:	EXTERNAL CONNECTION DIAGRAM
MODEL NO.: F48Z69A01 CUST. P/N: 782A HP: 1/4 ROT.: REVERSIBLE RPM: 1625/2 SPD TYPE: UF FRAME: 48Y VOLTS: 460 PH: 1 AMPS: 0.74/0.58 HZ: 60 INS.: B AMB.: 60° C DUTY: AIR OVER CAP.: 5 MFD/370 V ENCL: SEMI-ENCL UL LOGO CSA LOGO THERMALLY PROTECTED	

PERFORMANCE CURVE NO.	TORQUE @ 1625 RPM (25°C)	APPROVED SAMPLE	UL COMPONENT	CSA
C32724	16.1 OZ. FT.	0604338B	FILE # E46412 PRGY2	FILE # LR43341 CLASS # 4211-01

GEOMETRIC CHARACTERISTICS & SYMBOLS

- FLATNESS
- STRAIGHTNESS
- ∠ ANGULARITY
- ⊥ PERPENDICULARITY (SQUARENESS)
- ∥ PARALLELISM
- ROUNDNESS (CIRCULARITY)
- ∅ CYLINDRICITY
- △ PROFILE OF ANY SURFACE
- ∩ PROFILE OF ANY LINE
- ↗ RUNOUT
- ⊕ TRUE POSITION
- ◎ CONCENTRICITY
- ≡ SYMMETRY

ASME Y14.5M 1994

REGAL-BELOIT CORPORATION (RBC) PROVIDES TECHNICAL ASSISTANCE TO OUR CUSTOMERS IN SEVERAL AREAS. SINCE RBC DOES NOT RECEIVE ALL DATA CONCERNING THE USE AND APPLICATION OF THE MOTOR, THE SUITABILITY OF THE MOTOR FOR THE APPLICATION MUST BE DETERMINED BY THE CUSTOMER.

DIMENSIONS WITHOUT TOLERANCES ARE FOR REFERENCE ONLY.

DR BY: RALF. CHEN 07-04-2007

APPD:

THIRD ANGLE PROJECTION

EDS DATE 11-11-2011
 FORMAT REV G

CONFIDENTIAL: THIS DRAWING AND ITS INFORMATION ARE THE EXCLUSIVE AND CONFIDENTIAL PROPERTY OF REGAL-BELOIT CORPORATION AND ARE NOT TO BE DISCLOSED, DUPLICATED, DISTRIBUTED OR OTHERWISE USED WITHOUT THE WRITTEN CONSENT OF REGAL-BELOIT CORPORATION. -ALL RIGHTS RESERVED.

REGAL-BELOIT CORPORATION

DESCRIPTION: MODEL-RFHP-48FR OUTLINE

SIZE: C DWG NO: F48Z69A01

SCALE: NONE SHEET: 1

REVISION:	ECO	REVISADO POR:	FECHA:	APROBADO POR:	FECHA:
E	0025527	J.AGUILERA	04-24-2012	R.RASCON	04-24-2012

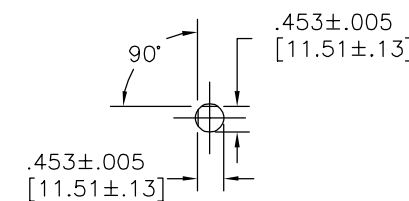
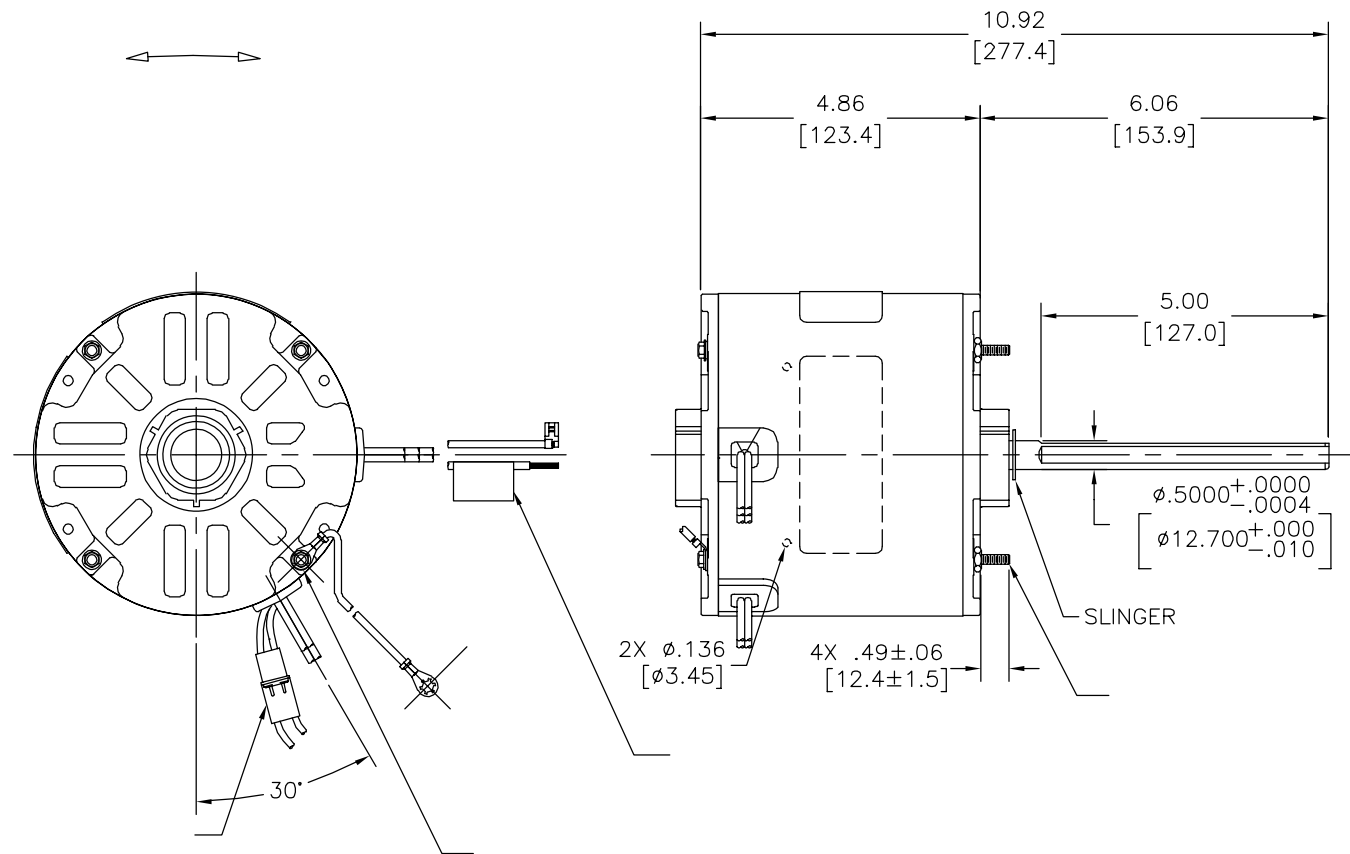

- NOTES:
- 1 CONDUIT BOX 52P7468-1-E308
 - 2 COVERS 46P93-1-E308
 - 1 GASKET 24P75-1
 - 4 SCREWS 21P258-25
- TO BE SHIPPED SEPARATE IN EACH CARTON WITH MOTOR.

CUERPO PPAL. -OLE	
TAPA FINAL- OLE	
CUERPO PPAL. -LE	
TAPA FINAL - LE	

	11.0/13.0	
	[279/330]	
	4.0/6.0	
	[102/152]	
	26.0/28.0	.25 [6.4] FLAG
	[660/711]	
	26.0/28.0	.25 [6.4] FLAG
	[660/711]	
	26.0/28.0	.50 [12.7] STRIP
	[660/711]	
	26.0/28.0	.50 [12.7] STRIP
	[660/711]	
	26.0/28.0	.50 [12.7] STRIP
	[660/711]	
	26.0/28.0	.50 [12.7] STRIP
	[660/711]	
COLOR	LONGITUD	TERMIANL O LONGITUD DE DESFORRE

F48Z69A01 782A	BROWN SEP. CAP.
1/4 REVERSIBLE 1625/2 SPD UF 48Y 460	BRN/WHT WHITE BLACK HI LINE PURPLE RED HI SPEED
1 0.74/0.58 60 B 60° C AIR OVER 5 MFD/370 V SEMI-ENCL	WHITE BLACK PURPLE ILINE RED LO LOW SPEED
	BLACK ROTATION BLACK WHITE CWLE WHITE BLACK CWLE WHITE WHITE CWLE BLACK

614131-349

CURVAS DE FUNCIONAMIENTO	TORSION @ 1625 RPM (25°C)	MUESTRA APROVADA	COMPONENTE UL	CSA
C32724	16.1 OZ. FT.	0604338B	#ARCHIVO CCN #	#ARCHIVO #CLASE
			E46412 PRGY2 LR43341	4211-01

CARACTERISTICAS DE GEOMETRIA Y SIMBOLOS

- ∠ PLANICIDAD
- RECTITUD
- ∠ ANGULARIDAD
- ⊥ PERPENDICULARIDAD (A ESCUADRA)
- // PARALELISMO
- REDONDEZ (CIRCULARIDAD)
- ∅ CILINDRICIDAD
- △ PERFIL DE CUALQUIER SUPERFICIE
- ∩ PERFIL DE CUALQUIER LINEA
- ∧ VARIACION
- ⊕ POSICION REAL
- ◎ CONCENTRICIDAD
- = SIMETRIA

ASME Y14.5M 1994

REGAL-BELOIT CORPORATION (RBC) PROVEE ASISTENCIA TECNICA A NUESTROS CLIENTES EN VARIAS AREAS. DESDE QUE RBC NO RECIBE TODOS LOS DATOS EN RELACION AL USO Y A LA APLICACION DEL MOTOR, LA APLICACION ADECUADA DEL MOTOR DEBE SER DETERMINADA POR EL CLIENTE.

DIMENSIONES SIN TOLERANCIA SON DE REFERENCIA SOLAMENTE

DIBUJADO POR: RALF. CHEN 07-04-2007

APROBADO POR:

TERCER ANGULO DE PROYECCION

FECHA EDS: 11-11-2011
REV. FORMATO: G

CONFIDENCIAL: ESTE DIBUJO Y SU INFORMACION SON PROPIEDAD DE USO EXCLUSIVO Y CONFIDENCIAL DE REGAL-BELOIT CORPORATION. Y NO DEBERAN SER REVELADOS, DUPLICADOS, DISTRIBUIDOS O USARSE DE OTRA MANERA SIN EL CONSENTIMIENTO ESCRITO DE REGAL-BELOIT CORPORATION. -TODOS LOS DERECHOS RESERVADOS.

REGAL-BELOIT CORPORATION

DESCRIPCION: MODEL-RFHP-48FR OUTLINE

TAMAÑO: C NUMERO DE DIBUJO: F48Z69A01

ESCALA: NONE HOJA: 1

版本	ECO	编制	日期	批准	日期
E	0025527	J.AGUILERA	04-24-2012	R.RASCON	04-24-2012

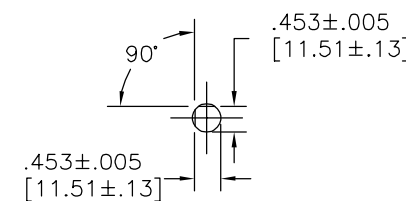
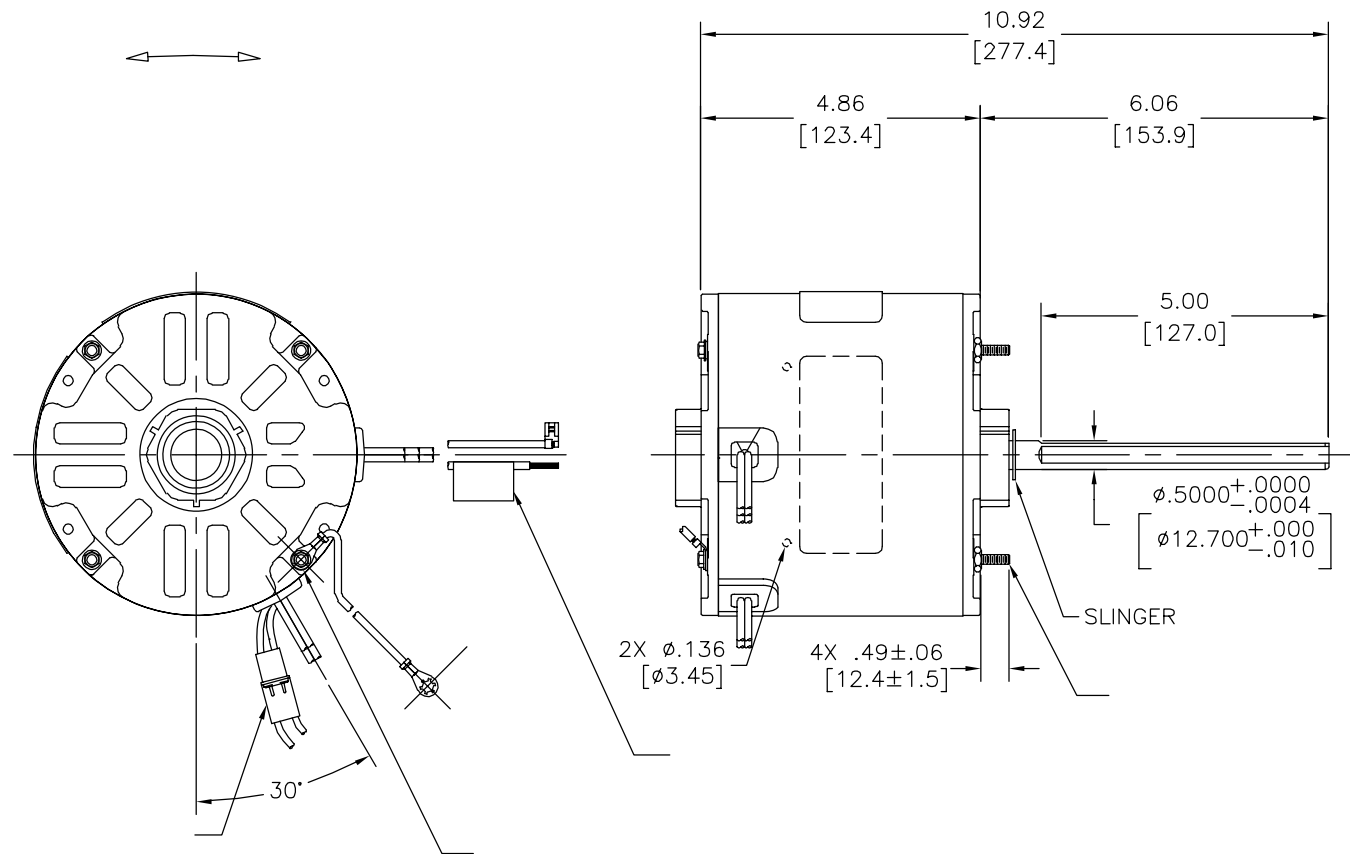

- NOTES:
- 1 CONDUIT BOX 52P7468-1-E308
 - 2 COVERS 46P93-1-E308
 - 1 GASKET 24P75-1
 - 4 SCREWS 21P258-25
- TO BE SHIPPED SEPARATE IN EACH CARTON WITH MOTOR.

	11.0/13.0	
	[279/330]	
	4.0/6.0	
	[102/152]	
	26.0/28.0	.25 [6.4] FLAG
	[660/711]	
	26.0/28.0	.25 [6.4] FLAG
	[660/711]	
	26.0/28.0	.50 [12.7] STRIP
	[660/711]	
	26.0/28.0	.50 [12.7] STRIP
	[660/711]	
	26.0/28.0	.50 [12.7] STRIP
	[660/711]	
	26.0/28.0	.50 [12.7] STRIP
	[660/711]	

F48Z69A01 782A	BROWN SEP. CAP.
1/4 REVERSIBLE 1625/2 SPD UF 48Y 460	BRN/WHT WHITE BLACK HI LINE PURPLE RED HI SPEED
1 0.74/0.58 60 B 60° C AIR OVER 5 MFD/370 V SEMI-ENCL	WHITE BLACK PURPLE ILINE RED LO LOW SPEED
	BLACK ROTATION BLACK WHITE CCWLE WHITE BLACK CWLE WHITE WHITE CWLE BLACK

614131-349

				CCN #	CSA
C32724	16.1 OZ. FT.	0604338B	E46412	PRGY2	LR43341 4211-01

- 形位公差
- 平面度
 - 直线度
 - ∠ 倾斜度
 - ⊥ 垂直度
 - // 平行度
 - 圆度
 - ⊘ 圆柱度
 - ⊖ 面轮廓度
 - △ 线轮廓度
 - ↗ 圆跳动
 - ⊕ 位置度
 - ⊙ 同轴度
 - ≡ 对称度

ASME Y14.5M 1994

REGAL-BELOIT CORPORATION (RBC) 在个别领域为客户提供技术支持。鉴于RBC未收到任何涉及电机使用和应用环境的数据，电机的适用性由客户自己决定。

未注公差尺寸仅供参考。

绘图: RALF. CHEN 07-04-2007

批准:

第三角投影

机密: 本图纸及相关信息所有权归REGAL-BELOIT CORPORATION。未经REGAL-BELOIT CORPORATION书面授权, 不得泄露、复制、传播或作其他用途。一版权所有

图纸格式发布日期 11-11-2011
图纸格式版本 G



MODEL-RFHP-48FR
OUTLINE

图号 F48Z69A01

名称	MODEL-RFHP-48FR OUTLINE	
图幅	C	图号 F48Z69A01
比例	NONE	页号 1

REV	ECO	REV BY	DATE	APPD	DATE
C	0007303	JLG	7-17-09	TR	7-17-09

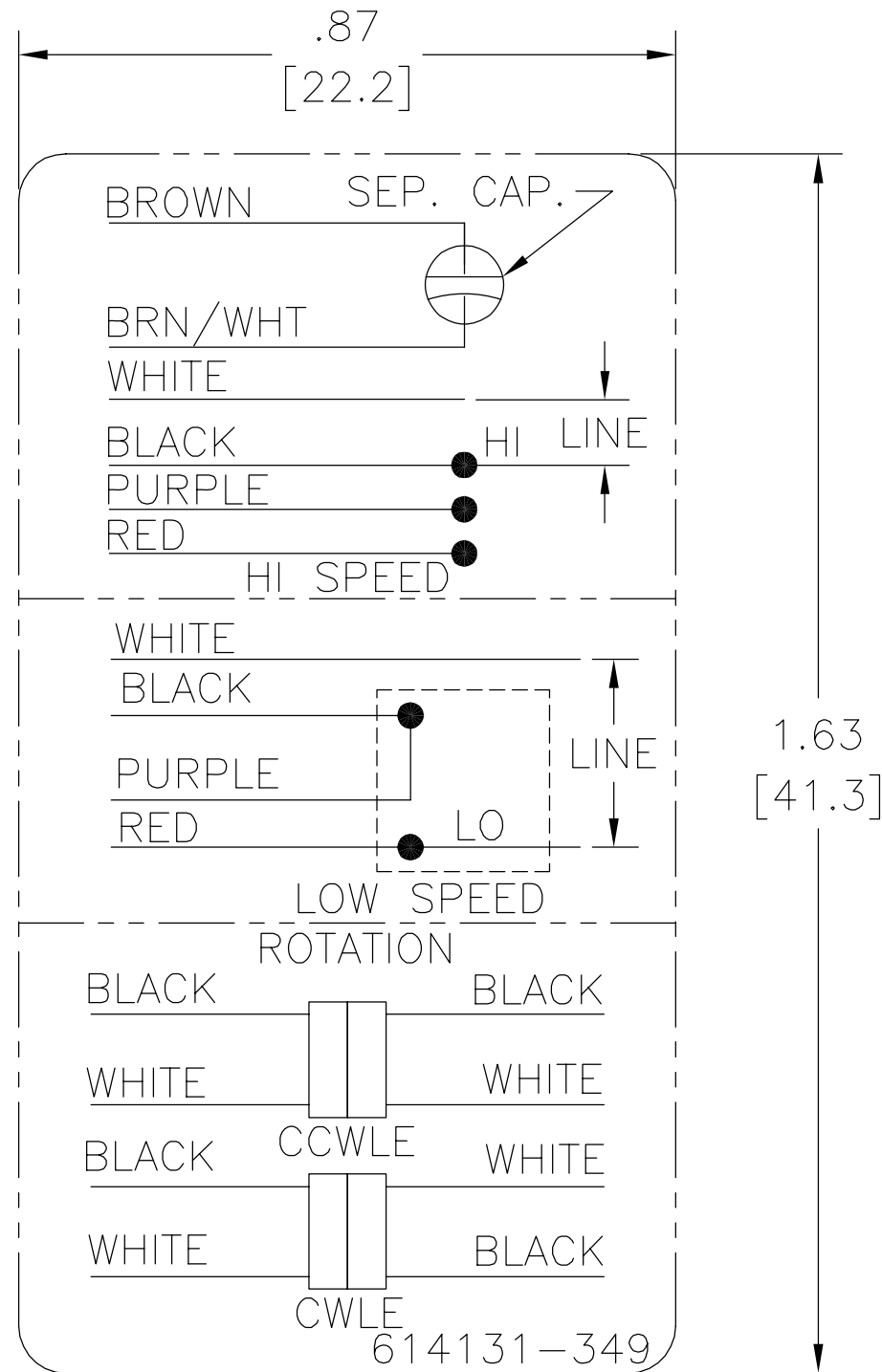

NOTES:

1. FOR USE WITH 614129 NAMEPLATE BLANK
2. ———— INDICATES DIMENSION LIMITS
3. DIE TO BE MADE FROM MASTER SUPPLIED BY A. O. SMITH CORPORATION
4. DIE MUST PRODUCE A LEGIBLE IMPRESSION.

GEOMETRIC CHARACTERISTICS & SYMBOLS
 ▭ FLATNESS
 — STRAIGHTNESS
 < ANGLARITY
 ⊥ PERPENDICULARITY (SQUARENESS)
 // PARALLELISM
 ○ ROUNDNESS (CIRCULARITY)
 ∅ CYLINDRICITY
 △ PROFILE OF ANY SURFACE
 ∩ PROFILE OF ANY LINE
 ↑ RUNOUT
 ⊕ TRUE POSITION
 ◎ CONCENTRICITY
 = SYMMETRY

UNLESS OTHERWISE SPECIFIED
 DIM. TOLERANCES ARE AS FOLLOWS:
 INCH X XX XXX XXXX
 ±.1 ±.02 ±.005 ±.0005
 mm ±0.5 ±0.13 ±0.013
 ANG. ±.50 DEG
 REMOVE BURRS & BREAK SHARP EDGES:
 INCH .003-.015 mm 0.1-0.4
 CORNER FILLETS TO:
 INCH .020 mm 0.5
 MACHINE SURFACES:
 INCH 125 mm 3.2
 METRIC DIMS. SHOWN IN [BRACKETS]

DR BY: L. Grado 02-05-2009
 APPD: C. Contreras 02-05-2009
 THIRD ANGLE PROJECTION
 EDS DATE 2-22-08
 FORMAT REV F
 CONFIDENTIAL: THIS DRAWING AND ITS INFORMATION ARE THE EXCLUSIVE AND CONFIDENTIAL PROPERTY OF A.O. SMITH CORP. AND ARE NOT TO BE DISCLOSED, DUPLICATED, DISTRIBUTED OR OTHERWISE USED WITHOUT THE WRITTEN CONSENT OF A.O. SMITH CORP.
 -ALL RIGHTS RESERVED. ASME Y14.5M 1994

ACSmith Innovation has a name.		ELECTRICAL PRODUCTS COMPANY A DIVISION OF A. O. SMITH CORPORATION	
DESCRIPTION CONN DIAGRAM-EXTERNAL			
SIZE A	DWG NO 614131-349		SHEET 1
SCALE NONE			

REVISION:	ECO	REVISADO POR:	FECHA:	APROBADO POR:	FECHA:
C	0007303	JLG	7-17-09	TR	7-17-09

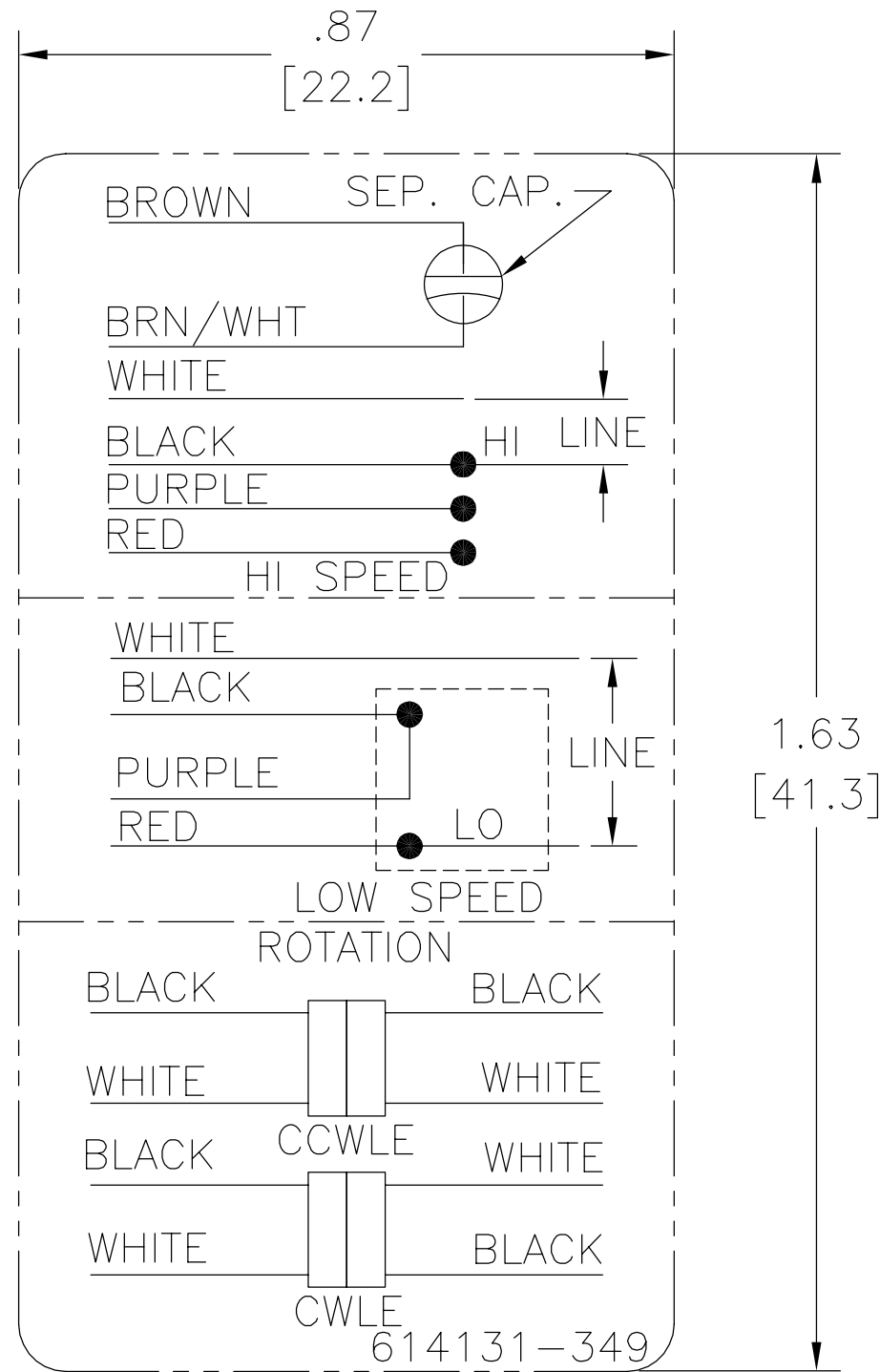

NOTAS:

1. PARA USAR CON 614129 PLACA DE DATOS EN BLANCO.
2. ———— INDICA LIMITES DE DIMENSION
3. EL MOLDE DEBE ESTAR HECHO DESDE EL PROVEEDOR PRINCIPAL POR A. O. SMITH CORPORATION
4. EL MOLDE DEBE PRODUCIR UNA IMPRESION LEGIBLE.

CARACTERISTICAS DE GEOMETRIA Y SIMBOLOS

- ▭ PLANICIDAD
- RECTITUD
- ∠ ANGULARIDAD
- ⊥ PERPENDICULARIDAD (A ESCUADRA)
- // PARALELISMO
- REDONDEZ (CIRCULARIDAD)
- ⊘ CILINDRICIDAD
- ⊖ PERFIL DE CUALQUIER SUPERFICIE
- ⌒ PERFIL DE CUALQUIER LINEA
- ↑ VARIACION
- ⊕ POSICION REAL
- ◎ CONCENTRICIDAD
- ≡ SIMETRIA

A MENOS QUE SE ESPECIFIQUE DE OTRA MANERA, LAS TOLERANCIAS DE LAS DIMS; SON LAS SIGUIENTES:

PULG	±.1	±.02	±.005	±.0005
mm	±0.5	±0.13	±0.013	

ANG. ±.50 GRADOS
 ELIMINAR REBABAS Y ORILLAS FILOSAS DEL BORDE.
 PULG .003-.015 mm 0.1-0.4
 FILETEAR ESQUINA: PULG .020 mm 0.5
 MAQUINAR SUPERFICIES
 PULG 125 mm 3.2
 DIMS METRICAS MOSTRADAS [PARENTESIS]

DIBUJADO POR: L. Grado	02-05-2009
APROBADO POR: C. Contreras	02-05-2009
TERCER ANGULO DE PROYECCION	FECHA EDS: 2-22-08 REV. FORMATO: F
CONFIDENCIAL: ESTE DIBUJO Y SU INFORMACION SON PROPIEDAD DE USO EXCLUSIVO Y CONFIDENCIAL DE A.O.SMITH CORP. Y NO DEBERAN SER REVELADOS, DUPLICADOS, DISTRIBUIDOS O USARSE DE OTRA MANERA SIN EL CONSENTIMIENTO ESCRITO DE A.O. SMITH CORP. -TODOS LOS DERECHOS RESERVADOS.ASME Y14.5M 1994	

 ELECTRICAL PRODUCTS COMPANY <small>A DIVISION OF A. O. SMITH CORPORATION</small>	
DESCRIPCION: CONN DIAGRAM-EXTERNAL	
TAMAÑO: A	NUMERO DE DIBUJO: 614131-349
ESCALA:NONE	HOJA: 1

??	ECO	??	??	??
C	0007303	JLG	7-17-09	TR

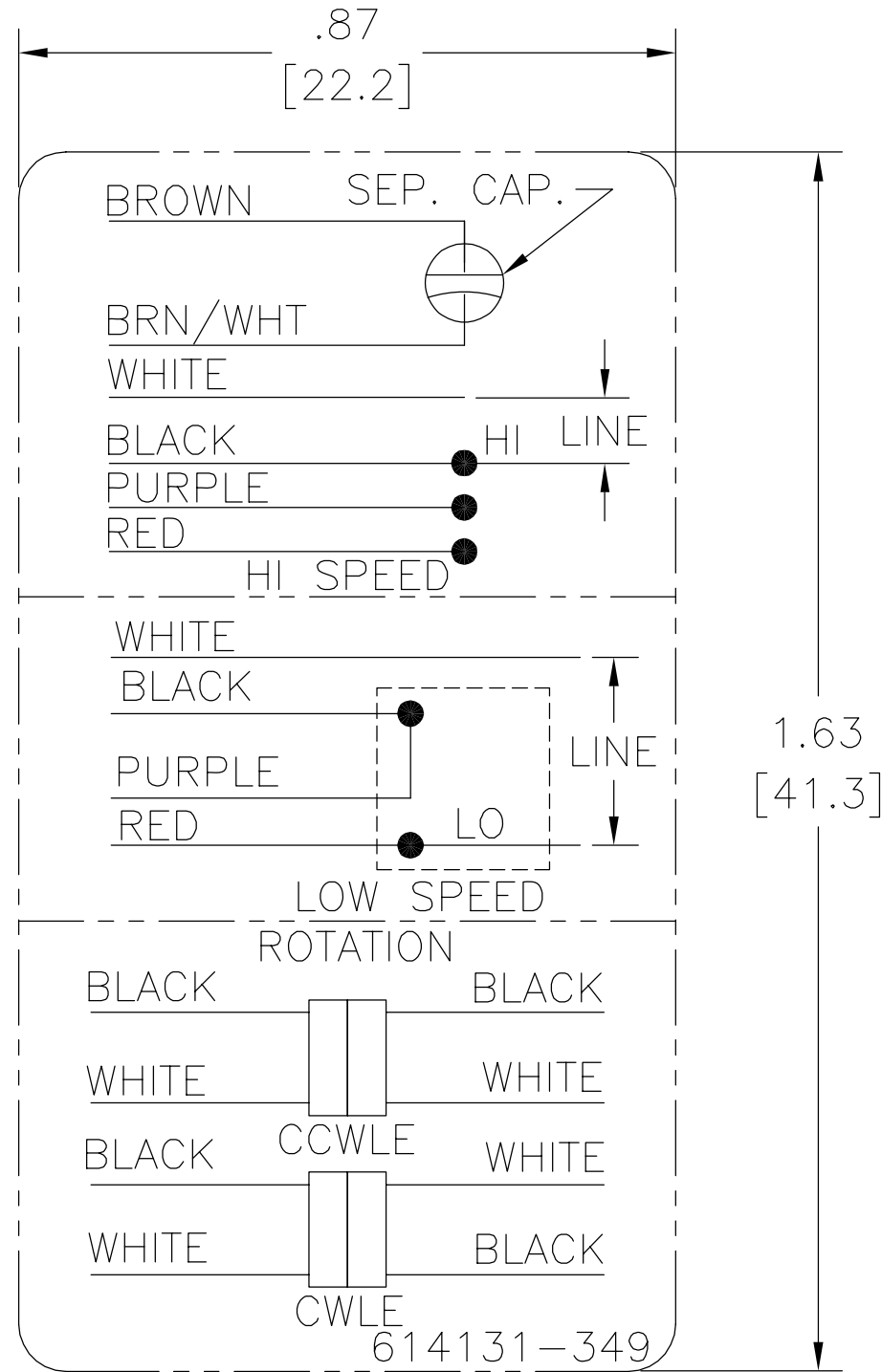

□ ???
 - ???
 < ???
 ⊥ ???
 // ???
 ○ ???
 ⊕ ???
 △ ???
 ∩ ???
 ↑ ???
 ⊕ ???
 ⊙ ???
 = ???

?????
 ??????
 ?? X XX XXX XXXX
 ?? ±.1 ±.02 ±.005 ±.0005
 ?? ±0.5 ±0.13 ±0.013
 ?? ±.50 ?
 ??????
 ?? .003-.015 ?? 0.1-0.4
 ???
 ?? .020 ?? 0.5
 ?????
 ?? 125 ?? 3.2
 ??????[]

??:	L. Grado	02-05-2009
??:	C. Contreras	02-05-2009
?????	⊕	?????? 2-22-08
		????? F
??:	????????????????A.O.SMITH?????	
??:	??A.O.SMITH????????????????????	
?????	?????--?????	
	ASME Y14.5M 1994	

		ELECTRICAL PRODUCTS COMPANY <small>A DIVISION OF A. O. SMITH CORPORATION</small>	
CONN DIAGRAM-EXTERNAL			
??	A	??	614131-349
??	NONE	??	1