

PRODUCT INFORMATION PACKET



Model No: 9432A

Catalog No: 9432A

Fan Coil & Air Conditioner Motor, 1/4,1/6,1/8 HP, 1 Ph, 60 Hz, 277 V, 1075 RPM, 3 Speed, 48 Frame,
OPEN



Regal and Century are trademarks of Regal Rexnord Corporation or one of its affiliated companies.
©2024 Regal Rexnord Corporation, All Rights Reserved. MC017097E





Nameplate Specifications

| | | | |
|--------------------|------------|---------------------|-----------------|
| Phase | 1 | Output HP | 1/4,1/6,1/8 Hp |
| Output KW | 0.19 kW | Voltage | 277 V |
| Speed | 1075 rpm | Service Factor | 1 |
| Frame | 48Y | Enclosure | Open Enclosed |
| Thermal Protection | Automatic | Ambient Temperature | 60 °C |
| Frequency | 60 Hz | Current | 1.2, .75, .55 A |
| Duty | Air Over | Insulation Class | B |
| UL | Recognized | CSA | Y |
| CE | N | Number of Speeds | 3 |

Technical Specifications

| | | | |
|-------------------|---------------------------|-----------------------|-----------------|
| Electrical Type | Permanent Split Capacitor | Starting Method | Across The Line |
| Poles | 6 | Rotation | Reversible |
| Mounting | Lug | Motor Orientation | Horizontal |
| Drive End Bearing | Ball | Opp Drive End Bearing | Ball |
| Frame Material | Rolled Steel | Shaft Type | Flat |
| Overall Length | 9.74 in | Frame Length | 3.63 in |
| Shaft Diameter | 0.500 in | Shaft Extension | 5.5 in |
| Outline Drawing | 9432A-S01 | Connection Drawing | 614131-351 |

This is an uncontrolled document once printed or downloaded and is subject to change without notice. Date Created:10/30/2024

GENERAL INFORMATION:

SHAFT RUNOUT: .001 [.03] T.I.R. PER INCH LENGTH OF EXTENSION

BEARINGS: BALL

MOUNTING POSITION: HORIZONTAL

ELECTRICAL DATA:

OVERLOAD PROTECTOR: AUTOMATIC RESET (T.I. 7AM 036)

LEADS: NO. 18 GA., .06 [1.5] THK., 105°C. PVC INSUL.
 REVERSING LEADS: NO. 18 GA., .03 [0.8] THK., 125°C. XLPE. INSUL.
 GROUND LEAD: NO. 18 GA., .03 [0.8] THK. GREEN/YELLOW INSUL.

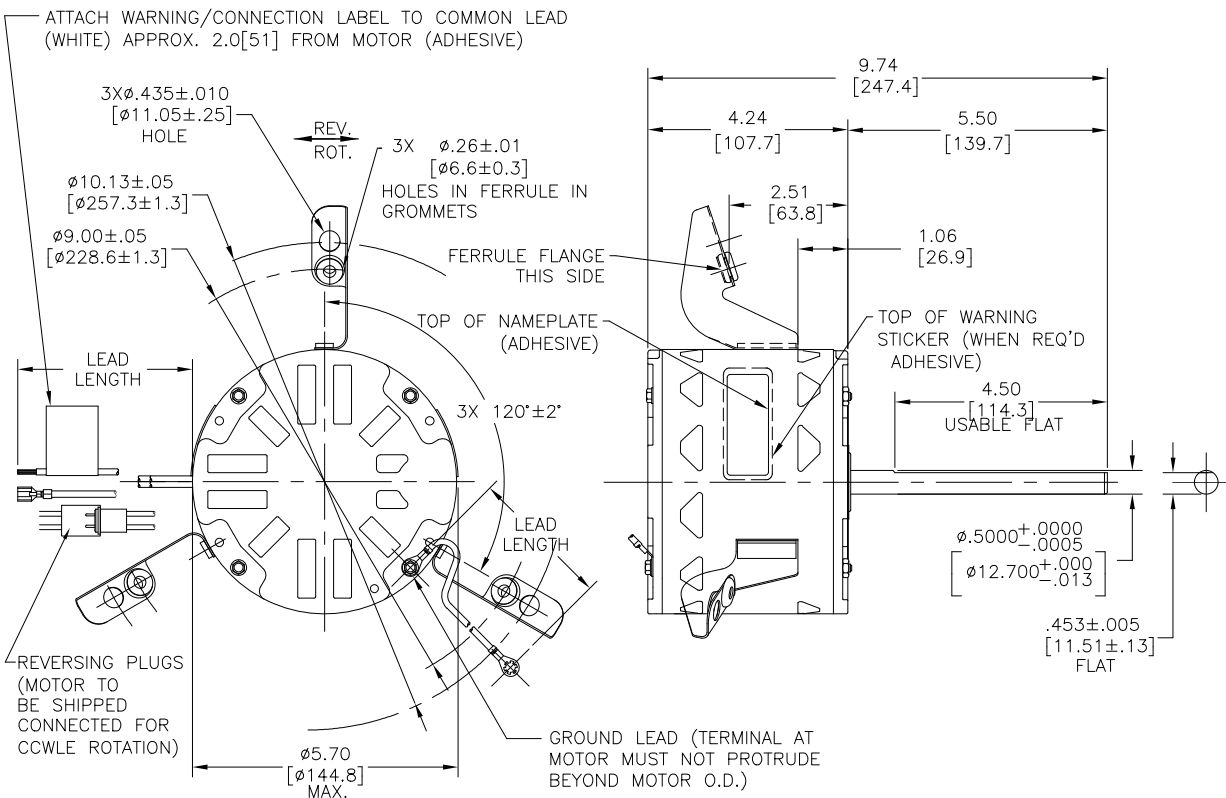

| NAMEPLATE DATA: | EXTERNAL CONNECTION DIAGRAM |
|------------------------------------------------------------------------------------------------------------------------------------------------------------------------------------------------------------------------------------------------------------------------------------------------------------------|-----------------------------|
| MODEL NO.: F48Y94A01 CUST. P/N: 9432A HP: 1/4 1/6, 1/8 ROT.: REV. RPM: 1075/3 SPD. TYPE: UF FRAME: 48Y VOLTS: 277 PH: 1 AMPS: 1.2, 0.75, 0.55 HZ: 60 INS.: B AMB.: 60° C DUTY: AIR OVER CAP.: 5 MFD/370 V ENCL.: OPEN UL LOGO CSA LOGO THERMALLY PROTECTED | |
| 614131-351 | |

| | | |
|--------------------|---------------------|--------------------------|
| GREEN/YELLOW (GRD) | 11.0/13.0 [279/330] | #10 EYELET |
| BLACK/WHITE | 3.0/5.0 [76/127] | REVERSING PLUG (MALE) |
| BLACK/WHITE | 3.0/5.0 [76/127] | REVERSING PLUG (FEMALE) |
| BROWN | 24.0/26.0 [610/660] | .25[6.4] FEMALE SPADE |
| BROWN/WHITE | 24.0/26.0 [610/660] | .25[6.4] FEMALE SPADE |
| RED | 24.0/26.0 [610/660] | .50[12.7] SKIN |
| BLUE | 24.0/26.0 [610/660] | .50[12.7] SKIN |
| WHITE | 24.0/26.0 [610/660] | .50[12.7] SKIN |
| BLACK | 24.0/26.0 [610/660] | .50[12.7] SKIN |
| COLOR | LENGTH | TERMINAL OR STRIP LENGTH |

REGAL-BELOIT CORPORATION (RBC) PROVIDES TECHNICAL ASSISTANCE TO OUR CUSTOMERS IN SEVERAL AREAS. SINCE RBC DOES NOT RECEIVE ALL DATA CONCERNING THE USE AND APPLICATION OF THE MOTOR, THE SUITABILITY OF THE MOTOR FOR THE APPLICATION MUST BE DETERMINED BY THE CUSTOMER.

DIMENSIONS WITHOUT TOLERANCES ARE FOR REFERENCE ONLY.

| | |
|------------------|------|
| MAIN FRAME - OLE | OPEN |
| END FRAME - OLE | OPEN |
| MAIN FRAME - LE | OPEN |
| END FRAME - LE | OPEN |

| PERFORMANCE CURVE NO. | TORQUE @ 1075 RPM (25°C) | APPROVED SAMPLE | UL COMPONENT | | | | CSA | |
|-----------------------|--------------------------|-----------------|--------------|-------|---------|---------|-----|--|
| C32683 | 22.1 OZ.FT | 0603138B | FILE # | CCN # | FILE # | CLASS # | | |
| | | | E46412 | PRGY2 | LR43341 | 4211-01 | | |

| | | | |
|--------------------------------------------|-------------------------------------------------------------------------------------------------------------------------------------------------------------------------------------------------------------------------------------------------------------------------------------------------------------------------------------------------------------------------------------------------------------------------------------------------------------------------------------------------------------------------------------------------------------------------------------------------------------------------------------------------------------------|---------------|------------|
| CRITICAL TO QUALITY CHARACTERISTICS (CTQs) | DRAWING REVISION | REVISION BY | DATE |
| | EEO | MINJING JIANG | 10-24-2024 |
| PROCESS | ECO | APPROVED BY | DATE |
| | NMR-0234769 | DEXIANJU | 10-24-2024 |
| ENGINEERING | UPDATE HOLE FOR MAIN FRME | | |
| | COPYRIGHT REGAL-BELOIT AMERICA, INC. ALL RIGHTS RESERVED. PROPRIETARY AND CONFIDENTIAL INFORMATION - THIS DOCUMENT IS THE PROPERTY OF REGAL-BELOIT AMERICA, INC. (OWNER) AND COMPANY OWNER'S PROPRIETARY INFORMATION. ANY PERSON, CORPORATION OR OTHER ENTITY, DUPLICATED, AND/OR USED, BY RECEIVING IT, TO AGREE THAT IT, AND/OR ANY PART OF IT, SHALL NOT BE DISCLOSED TO ANY PERSON, CORPORATION OR OTHER ENTITY, DUPLICATED, AND/OR USED, EXCEPT AS EXPRESSLY APPROVED IN WRITING IN ADVANCE BY OWNER. THIS DOCUMENT SHALL BE RETURNED TO OWNER UPON REQUEST. IT MAY BE SUBJECT TO CERTAIN RESTRICTIONS UNDER APPLICABLE EXPORT CONTROL LAWS AND REGULATIONS. | | |
| APPLICATION | | | |
| REGULATORY | | | |
| LIFE | | | |

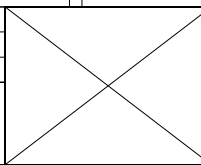

| | | | |
|-----------|--|--------------------------------------|--|
| ENCLOSURE | | DRAWN BY: B.Z. | |
| | | DATE: 04-19-2011 | |
| | | APPROVED BY: C.Z. | |
| | | DATE: 04-19-2011 | |
| | | PROCESS/FINISH | |
| | | THIRD ANGLE PROJECTION | |
| | | REGAL-BELOIT America, Inc. | |
| | | DESCRIPTION: MODEL-RFHP-48FR OUTLINE | |
| | | MATERIAL: - | |
| | | SIZE DWG NO: 9432A | |
| | | SHEET 1 | |

NOTE
 1. CTQ REQUIREMENT SEE EP000105-008.
 2. RoHS & REACH ETC REQUIREMENT SEE EP000014

| | | | | | |
|-----|---------|--------|------------|--------|------------|
| REV | ECO | REV BY | DATE | APPD | DATE |
| C | 0027023 | N.HONG | 06-24-2012 | B.SHEN | 06-24-2012 |

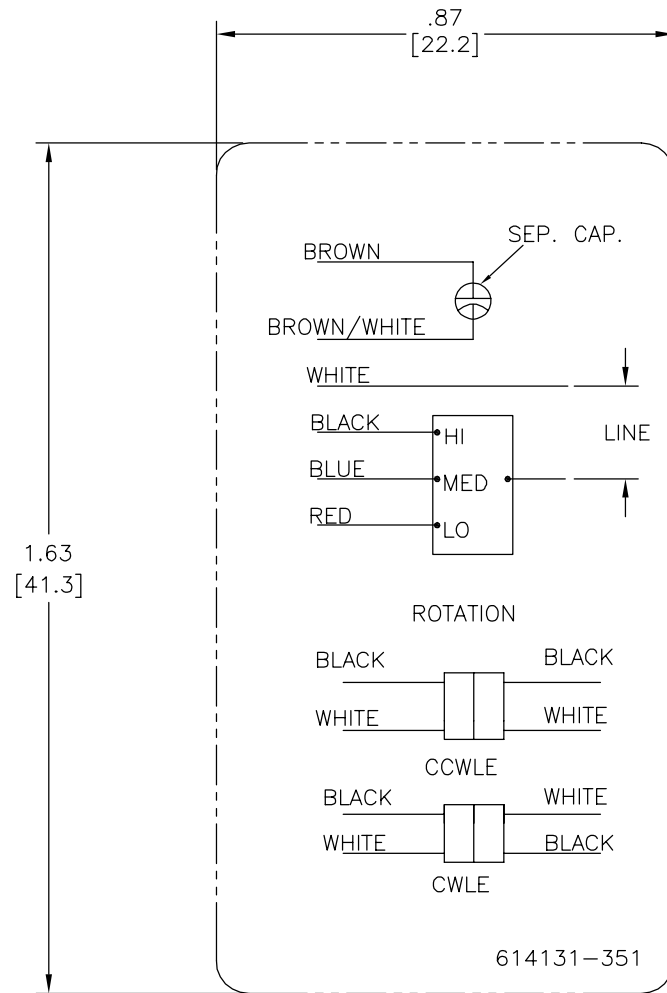

NOTES:

1. FOR USE WITH 614129 OR 2513020-001 NAMEPLATE BLANKS;
2. ——— INDICATES DIMENSION LIMITS

| GEOMETRIC CHARACTERISTICS & SYMBOLS | |
|-------------------------------------|-------------------------------|
| ▭ | FLATNESS |
| — | STRAIGHTNESS |
| ∠ | ANGULARITY |
| ⊥ | PERPENDICULARITY (SQUARENESS) |
| // | PARALLELISM |
| ○ | ROUNDNESS (CIRCULARITY) |
| ⊘ | CYLINDRICITY |
| △ | PROFILE OF ANY SURFACE |
| ∧ | PROFILE OF ANY LINE |
| ↗ | RUNOUT |
| ⊕ | TRUE POSITION |
| ◎ | CONCENTRICITY |
| ≡ | SYMMETRY |

| | |
|---------------------------------------------------------------|-------------------------------------|
| UNLESS OTHERWISE SPECIFIED DIM. TOLERANCES ARE AS FOLLOWS: | |
| INCH | X ±.1 XX ±.02 XXX ±.005 XXXX ±.0005 |
| mm | ±0.5 ±0.13 ±0.013 |
| ANG. ±.50 DEG | |
| REMOVE BURRS & BREAK SHARP EDGES: | |
| INCH | .003-.015 mm 0.1-0.4 |
| CORNER FILLETS TO: | |
| INCH | .020 mm 0.5 |
| MACHINE SURFACES: | |
| INCH | 125 mm 3.2 |
| METRIC DIMS. SHOWN IN [BRACKETS] | |

| | | |
|------------------------------------------------------------------------------------------------------------------------------------------------------------------------------------------------------------------------------------------------------------------------------|----|-------------------------------------|
| DR BY: | YL | 04-08-2011 |
| APPD: | CZ | 04-08-2011 |
| THIRD ANGLE PROJECTION | ⊕ | EDS DATE 11-11-2011 FORMAT REV H |
| CONFIDENTIAL: THIS DRAWING AND ITS INFORMATION ARE THE EXCLUSIVE AND CONFIDENTIAL PROPERTY OF REGAL-BELOIT CORPORATION AND ARE NOT TO BE DISCLOSED, DUPLICATED, DISTRIBUTED OR OTHERWISE USED WITHOUT THE WRITTEN CONSENT OF REGAL-BELOIT CORPORATION. -ALL RIGHTS RESERVED. | | |

| | |
|---------------------------------------|----------------------|
| REGAL REGAL-BELOIT CORPORATION | |
| DESCRIPTION CONN DIAGRAM-NAMEPLATE | |
| SIZE C | DWG NO 614131-351 |
| SCALE NONE | SHEET 1 |

4

3

2

1

| | | | | | |
|-----------|---------|---------------|------------|---------------|------------|
| REVISION: | ECO | REVISADO POR: | FECHA: | APROBADO POR: | FECHA: |
| C | 0027023 | N.HONG | 06-24-2012 | B.SHEN | 06-24-2012 |

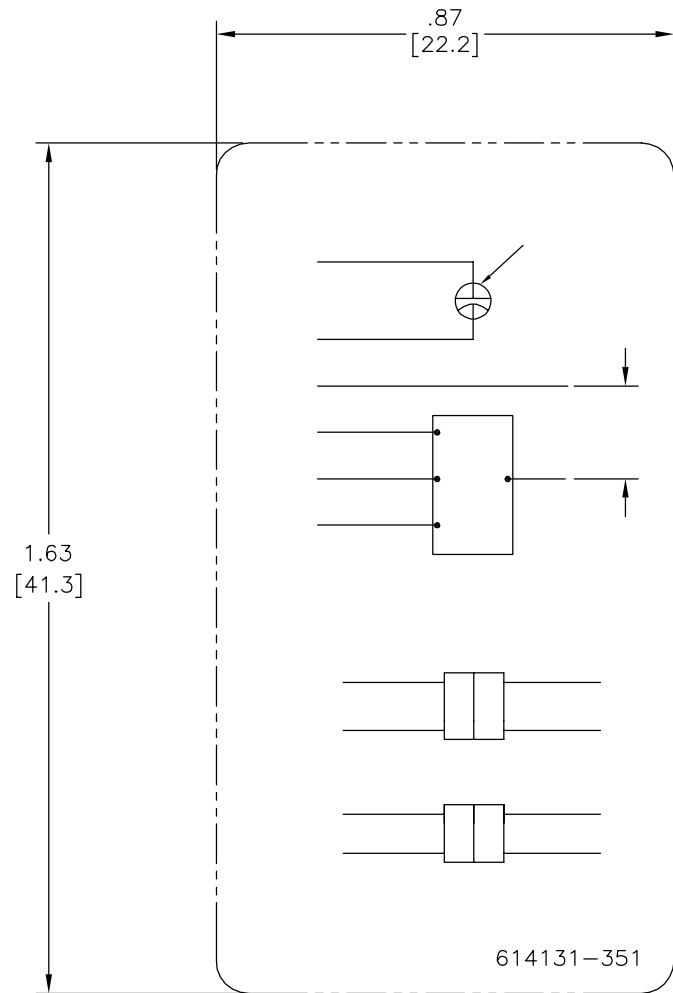

CARACTERISTICAS DE GEOMETRIA Y SIMBOLOS

- ▧ PLANICIDAD
- RECTITUD
- ∠ ANGULARIDAD
- ⊥ PERPENDICULARIDAD (A ESCUADRA)
- // PARALELISMO
- REDONDEZ (CIRCULARIDAD)
- ⊘ CILINDRICIDAD
- △ PERFIL DE CUALQUIER SUPERFICIE
- ▽ PERFIL DE CUALQUIER LINEA
- ↗ VARIACION
- ⊕ POSICION REAL
- ◎ CONCENTRICIDAD
- ≡ SIMETRIA

ASME Y14.5M 1994

A MENOS QUE SE ESPECIFIQUE DE OTRA MANERA, LAS TOLERANCIAS DE LAS DIMS; SON LAS SIGUIENTES:

| | | | | | |
|--|------|------|-------|--------|--------|
| | PULG | ±.1 | ±.02 | ±.005 | ±.0005 |
| | mm | ±0.5 | ±0.13 | ±0.013 | |

ANG. ± 50 GRADOS
ELIMINAR REBABAS Y ORILLAS FILOSAS DEL BORDE.

| | | | | |
|--|------|-----------|----|---------|
| | PULG | .003-.015 | mm | 0.1-0.4 |
|--|------|-----------|----|---------|

FILETEAR ESQUINA: PULG .020 mm 0.5
MAQUINAR SUPERFICIES
PULG 125 mm 3.2

DIMS METRICAS MOSTRADAS [PARENTESIS]

| | | |
|-----------------------------------------------------------------------------------------------------------------------------------------------------------------------------------------------------------------------------------------------------------------------------------------------|----|------------------------------------------|
| DIBUJADO POR: | YL | 04-08-2011 |
| APROBADO POR: | CZ | 04-08-2011 |
| TERCER ANGULO DE PROYECCION | ⊕ | FECHA EDS: 11-11-2011 REV. FORMATO: H |
| CONFIDENCIAL: ESTE DIBUJO Y SU INFORMACION SON PROPIEDAD DE USO EXCLUSIVO Y CONFIDENCIAL DE REGAL-BELOIT CORPORATION. Y NO DEBERAN SER REVELADOS, DUPLICADOS, DISTRIBUIDOS O USARSE DE OTRA MANERA SIN EL CONSENTIMIENTO ESCRITO DE REGAL-BELOIT CORPORATION. -TODOS LOS DERECHOS RESERVADOS. | | |

| | |
|----------------------------------------|---------------------------------|
| REGAL REGAL-BELOIT CORPORATION | |
| DESCRIPCION: CONN DIAGRAM-NAMEPLATE | |
| TAMAÑO: C | NUMERO DE DIBUJO: 614131-351 |
| ESCALA: NONE | HOJA: 1 |

4

3

2

1

4

3

2

1

| | | | | | |
|----|---------|--------|------------|--------|------------|
| 版本 | ECO | 编制 | 日期 | 批准 | 日期 |
| C | 0027023 | N.HONG | 06-24-2012 | B.SHEN | 06-24-2012 |

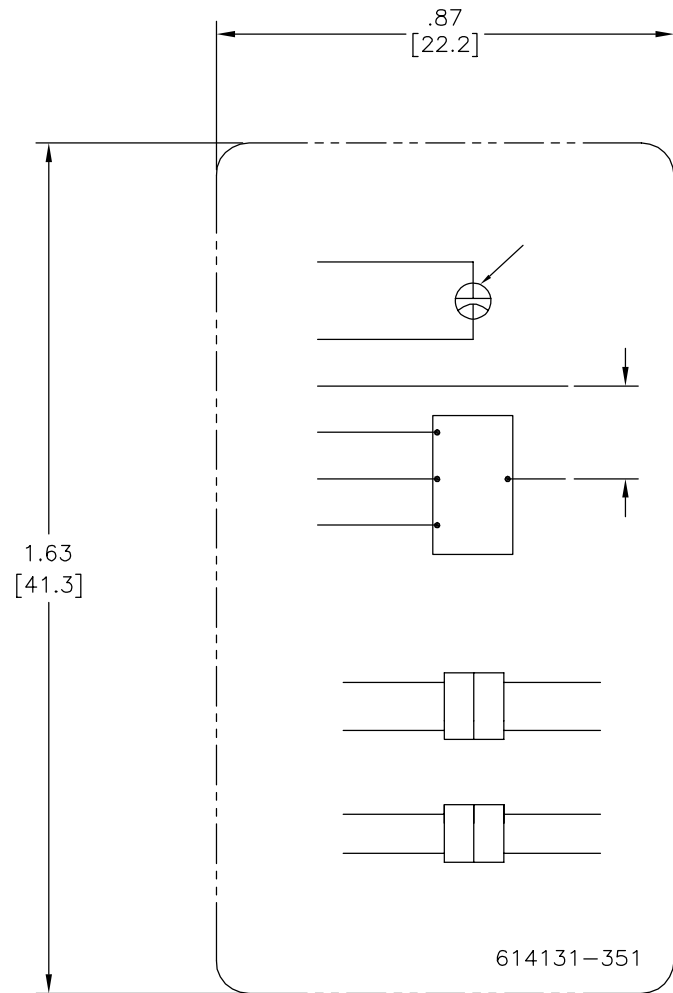

| |
|--------|
| 形位公差 |
| □ 平面度 |
| — 直线度 |
| ∠ 倾斜度 |
| ⊥ 垂直度 |
| // 平行度 |
| ○ 圆度 |
| ⊘ 圆柱度 |
| △ 面轮廓度 |
| ∩ 线轮廓度 |
| ↗ 圆跳动 |
| ⊕ 位置度 |
| ⊙ 同轴度 |
| ≡ 对称度 |

| |
|------------------------------|
| 除另有注明 尺寸公差如下: |
| 英寸 X XX XXX XXXX |
| 毫米 ±0.1 ±0.02 ±0.005 ±0.0005 |
| 角度 ±.50 度 |
| 清理毛刺和尖棱 |
| 英寸 .003-.015 毫米 0.1-0.4 |
| 内圆角 |
| 英寸 .020 毫米 0.5 |
| 表面粗糙度 |
| 英制 125 米制 3.2 |
| 米制尺寸显示在 [] |

| | | |
|--------------------------------------------------------------------------------------------------------|----|---------------------------------|
| 绘图: | YL | 04-08-2011 |
| 批准: | CZ | 04-08-2011 |
| 第三角投影 | | 图纸格式发布日期 11-11-2011 图纸格式版本 H |
| 机密: 本图纸及相关信息所有权归REGAL-BELOIT CORPORATION 未经REGAL-BELOIT CORPORATION书面授权, 不得泄露、 复制、传播或作其他用途。—版权所有 | | |

| | |
|---------------------------------|------------------------|
| REGAL-BELOIT CORPORATION | |
| 名称 | CONN DIAGRAM-NAMEPLATE |
| 图幅 | C |
| 图号 | 614131-351 |
| 比例 | NONE |
| 页号 | 1 |

4

3

2

1

TRACKING #: 10053995
 SBU: Heating & Air Cond
 ENGINEER: JAMES PENG
 TECHNICIAN: DAN THOMPSON
 TORQUE CELL: 250-1 inlb
 NP RPM: 1075
 # SPEEDS: 3
 MOTOR #: 1
 COMMENT 2:

CUSTOMER: DISTRIBUTION SERVICES
 MODEL: 0603138B
 FRAME: 48
 PHASES: 1
 VOLTS: 277.0
 HERTZ: 60
 RUN CAP: 5.00
 COMMENT1:
 COMMENT 3:

DESCRIPTION: SYNC-0
 TYPE: PSC
 BENCH: 1
 HP: 0.25
 ROTATION: CW
 BDT: 16.77
 LRA: 1.50
 LRT: 4.02
 COMMENT 4:

Resistance:

Friction: -0.9735 ozft @ 200 RPM
 Friction + Wind: -1.2822 ozft @ 1080 RPM
 Inertia: 0.0179 ozft

| | Start | Main1 | |
|--------|--------|--------|----------|
| | 03-02 | 01-02 | |
| Spec | 10.00 | 0.00 | |
| Before | 81.283 | 55.188 | @23.5 °C |
| After | 81.722 | 55.607 | @23.2 °C |

Down Results (Torque In ozft):

| % Load | Torque | RPM | VLine | VCap | VStart | ILine | IMain | IStart | WLine | WOut | % Eff | % PF | HP |
|--------|--------|--------|-------|-------|--------|-------|-------|--------|-------|-------|-------|-------|------|
| NL | 0.00 | 1191.9 | 277.1 | 336.4 | 219.1 | 0.21 | 0.55 | 0.64 | 56.7 | 0.0 | 0.0 | 97.4 | 0.00 |
| NP+100 | 3.85 | 1175.0 | 276.8 | 323.4 | 213.8 | 0.30 | 0.49 | 0.61 | 83.4 | 40.1 | 48.1 | 100.0 | 0.05 |
| NP+80 | 6.97 | 1155.0 | 276.6 | 308.3 | 206.8 | 0.40 | 0.47 | 0.59 | 111.1 | 71.4 | 64.3 | 100.0 | 0.10 |
| NP+60 | 9.43 | 1135.0 | 276.4 | 294.6 | 199.7 | 0.49 | 0.49 | 0.56 | 136.2 | 95.0 | 69.7 | 100.0 | 0.13 |
| NP-50* | 10.49 | 1125.0 | 276.3 | 288.2 | 196.2 | 0.54 | 0.51 | 0.55 | 147.7 | 104.7 | 70.9 | 99.0 | 0.14 |
| NP+40 | 11.44 | 1115.0 | 276.1 | 282.1 | 192.6 | 0.58 | 0.54 | 0.54 | 158.7 | 113.2 | 71.3 | 99.1 | 0.15 |
| NP-25* | 12.67 | 1100.0 | 276.1 | 274.0 | 187.5 | 0.64 | 0.58 | 0.52 | 174.3 | 123.7 | 71.0 | 98.6 | 0.17 |
| NP+20 | 13.04 | 1095.0 | 276.3 | 271.7 | 185.9 | 0.66 | 0.60 | 0.52 | 179.5 | 126.7 | 70.6 | 98.4 | 0.17 |
| NP | 14.40 | 1075.0 | 277.7 | 263.5 | 180.3 | 0.74 | 0.68 | 0.50 | 200.3 | 137.4 | 68.6 | 97.5 | 0.18 |
| NP-20 | 15.42 | 1055.0 | 278.4 | 255.9 | 174.2 | 0.81 | 0.75 | 0.49 | 217.9 | 144.4 | 66.3 | 96.6 | 0.19 |
| NP+25* | 15.62 | 1050.0 | 278.5 | 254.2 | 172.8 | 0.82 | 0.77 | 0.48 | 221.8 | 145.5 | 65.6 | 97.1 | 0.20 |
| NP-40 | 16.10 | 1035.0 | 278.6 | 249.1 | 168.2 | 0.86 | 0.82 | 0.47 | 232.4 | 147.9 | 63.6 | 97.0 | 0.20 |
| NP+50* | 16.33 | 1025.0 | 278.3 | 245.7 | 165.1 | 0.89 | 0.86 | 0.47 | 238.4 | 148.5 | 62.3 | 96.3 | 0.20 |
| NP-60 | 16.44 | 1015.0 | 277.7 | 242.4 | 161.9 | 0.92 | 0.89 | 0.46 | 243.4 | 148.1 | 60.8 | 95.3 | 0.20 |
| NP-80 | 16.62 | 995.0 | 277.2 | 237.0 | 156.1 | 0.96 | 0.95 | 0.45 | 253.3 | 146.7 | 57.9 | 95.2 | 0.20 |
| NP-100 | 16.76 | 975.0 | 277.2 | 232.7 | 150.9 | 1.01 | 1.01 | 0.44 | 262.7 | 145.0 | 55.2 | 93.8 | 0.19 |
| MT | 16.77 | 965.1 | 277.2 | 230.9 | 148.4 | 1.03 | 1.03 | 0.44 | 266.8 | 143.6 | 53.8 | 93.4 | 0.19 |
| BDT | 16.77 | 965.1 | 277.2 | 230.9 | 148.4 | 1.03 | 1.03 | 0.44 | 266.8 | 143.6 | 53.8 | 93.4 | 0.19 |
| NP-200 | 16.12 | 875.0 | 277.2 | 220.1 | 128.5 | 1.17 | 1.24 | 0.42 | 293.9 | 125.2 | 42.6 | 90.6 | 0.17 |
| NP-300 | 14.45 | 775.0 | 277.0 | 216.3 | 111.5 | 1.28 | 1.40 | 0.41 | 310.2 | 99.4 | 32.0 | 87.5 | 0.13 |
| NP-400 | 12.65 | 675.0 | 276.9 | 216.5 | 98.2 | 1.36 | 1.51 | 0.41 | 319.2 | 75.8 | 23.7 | 84.8 | 0.10 |
| HS | 11.33 | 600.0 | 276.8 | 217.8 | 90.2 | 1.40 | 1.58 | 0.41 | 322.7 | 60.3 | 18.7 | 83.3 | 0.08 |
| PUT | 4.01 | 30.0 | 277.4 | 237.8 | 51.1 | 1.51 | 1.78 | 0.45 | 332.5 | 1.1 | 0.3 | 79.4 | 0.00 |
| LR | 4.02 | 0.0 | 277.1 | 237.6 | 51.1 | 1.50 | 1.78 | 0.45 | 331.5 | 0.0 | 0.0 | 79.8 | 0.00 |

LRA=LOCKED ROTOR AMPS BDT =BREAKDOWN TORQUE MT=MAX TORQUE
 LRT=LOCKED ROTOR TORQUE NP RPM=NAMEPLATE RPM

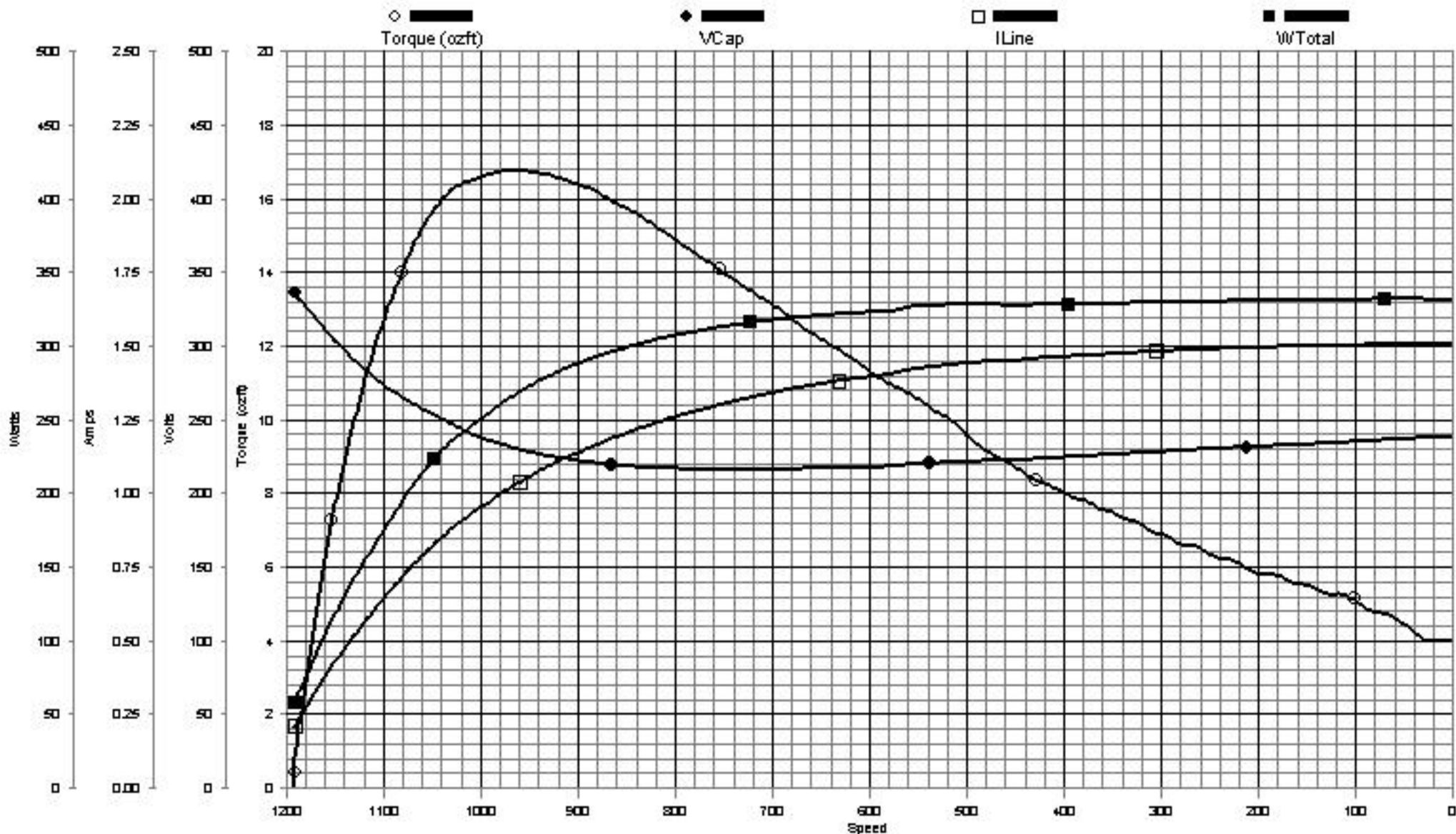

TRACKING #: 10053995
 SBU: Heating & Air Cond
 ENGINEER: JAMES PENG
 TECHNICIAN: DAN THOMPSON
 TORQUE CELL: 250-1 inlb
 NP RPM: 1075
 # SPEEDS: 3
 MOTOR #: 1
 COMMENT 2:

CUSTOMER: DISTRIBUTION SERVICES
 MODEL: 0603138B
 FRAME: 48
 PHASES: 1
 VOLTS: 277.0
 HERTZ: 60
 RUN CAP: 5.00
 COMMENT 1:
 COMMENT 3:

DESCRIPTION: SYNC-0
 TYPE: PSC
 BENCH: 1
 HP: 0.25
 ROTATION: CW
 EDT: 16.77
 LRA: 1.50
 LET: 4.02
 COMMENT 4:

TRACKING #: 10053995
 SBU: Heating & Air Cond
 ENGINEER: JAMES PENG
 TECHNICIAN: DAN THOMPSON
 TORQUE CELL: 250-1 inlb
 NP RPM: 1075
 # SPEEDS: 3
 MOTOR #: 1
 COMMENT 2:

CUSTOMER: DISTRIBUTION SERVICES
 MODEL: 0603138B
 FRAME: 48
 PHASES: 1
 VOLTS: 277.0
 HERTZ: 60
 RUN CAP: 5.00
 COMMENT1:
 COMMENT 3:

DESCRIPTION: SYNC-0
 TYPE: PSC
 BENCH: 1
 HP: 0.25
 ROTATION: CW
 BDT: 12.90
 LRA: 1.15
 LRT: 3.30
 COMMENT 4:

Resistance:

Friction: -1.0402 ozft @ 200 RPM
 Friction + Wind: -1.2751 ozft @ 1080 RPM
 Inertia: 0.0180 ozft

| | Start | Main1 | |
|--------|--------|--------|----------|
| | 03-02 | 01-02 | |
| Spec | 10.00 | 0.00 | |
| Before | 81.262 | 71.036 | @23.2 °C |
| After | 81.565 | 71.377 | @23.1 °C |

Down Results (Torque In ozft):

| % Load | Torque | RPM | VLine | VCap | VStart | ILine | IMain | IStart | WLine | WOut | % Eff | % PF | HP |
|--------|--------|--------|-------|-------|--------|-------|-------|--------|-------|-------|-------|-------|------|
| NL | 0.00 | 1190.9 | 277.3 | 291.6 | 200.3 | 0.15 | 0.48 | 0.55 | 42.7 | 0.0 | 0.0 | 100.0 | 0.00 |
| NP+100 | 2.91 | 1175.0 | 277.0 | 280.4 | 197.6 | 0.23 | 0.43 | 0.53 | 62.5 | 30.3 | 48.5 | 98.1 | 0.04 |
| NP+80 | 5.31 | 1155.0 | 276.8 | 266.8 | 193.4 | 0.31 | 0.40 | 0.51 | 84.8 | 54.4 | 64.2 | 98.8 | 0.07 |
| NP+60 | 7.20 | 1135.0 | 276.6 | 254.5 | 189.0 | 0.38 | 0.40 | 0.48 | 103.5 | 72.5 | 70.1 | 98.5 | 0.10 |
| NP-50* | 8.01 | 1125.0 | 276.5 | 248.8 | 186.8 | 0.41 | 0.41 | 0.47 | 112.0 | 80.0 | 71.4 | 98.8 | 0.11 |
| NP+40 | 8.72 | 1115.0 | 276.4 | 243.5 | 184.6 | 0.44 | 0.43 | 0.46 | 120.2 | 86.3 | 71.8 | 98.8 | 0.12 |
| NP-25* | 9.61 | 1100.0 | 276.3 | 236.1 | 181.2 | 0.48 | 0.46 | 0.45 | 131.6 | 93.8 | 71.3 | 99.2 | 0.13 |
| NP+20 | 9.89 | 1095.0 | 276.2 | 233.8 | 180.1 | 0.50 | 0.47 | 0.44 | 135.2 | 96.1 | 71.1 | 97.9 | 0.13 |
| NP | 10.89 | 1075.0 | 276.5 | 225.6 | 175.8 | 0.55 | 0.53 | 0.43 | 149.9 | 103.9 | 69.3 | 98.6 | 0.14 |
| NP-20 | 11.70 | 1055.0 | 277.6 | 219.1 | 172.0 | 0.61 | 0.58 | 0.42 | 163.7 | 109.5 | 66.9 | 96.7 | 0.15 |
| NP+25* | 11.85 | 1050.0 | 277.8 | 217.6 | 171.0 | 0.62 | 0.59 | 0.41 | 166.8 | 110.4 | 66.2 | 96.8 | 0.15 |
| NP-40 | 12.21 | 1035.0 | 277.8 | 213.1 | 167.8 | 0.65 | 0.63 | 0.40 | 174.8 | 112.1 | 64.2 | 96.8 | 0.15 |
| NP+50* | 12.42 | 1025.0 | 277.9 | 210.4 | 165.8 | 0.68 | 0.66 | 0.40 | 179.8 | 113.0 | 62.8 | 95.1 | 0.15 |
| NP-60 | 12.61 | 1015.0 | 278.2 | 208.1 | 164.0 | 0.70 | 0.69 | 0.40 | 184.8 | 113.6 | 61.5 | 94.9 | 0.15 |
| NP-80 | 12.84 | 995.0 | 278.3 | 203.6 | 160.1 | 0.73 | 0.73 | 0.39 | 193.3 | 113.4 | 58.7 | 95.1 | 0.15 |
| BDT | 12.90 | 980.0 | 277.9 | 200.4 | 157.0 | 0.76 | 0.77 | 0.38 | 198.3 | 112.2 | 56.6 | 93.9 | 0.15 |
| MT | 12.90 | 980.0 | 277.9 | 200.4 | 157.0 | 0.76 | 0.77 | 0.38 | 198.3 | 112.2 | 56.6 | 93.9 | 0.15 |
| NP-100 | 12.89 | 975.0 | 277.7 | 199.3 | 156.0 | 0.77 | 0.78 | 0.38 | 199.7 | 111.5 | 55.8 | 93.4 | 0.15 |
| NP-200 | 12.40 | 875.0 | 277.2 | 187.8 | 139.1 | 0.90 | 0.96 | 0.36 | 224.0 | 96.3 | 43.0 | 89.8 | 0.13 |
| NP-300 | 11.16 | 775.0 | 277.2 | 184.5 | 126.1 | 0.98 | 1.09 | 0.35 | 237.1 | 76.8 | 32.4 | 87.3 | 0.10 |
| NP-400 | 9.81 | 675.0 | 277.2 | 184.9 | 115.8 | 1.04 | 1.18 | 0.35 | 243.8 | 58.8 | 24.1 | 84.6 | 0.08 |
| HS | 8.78 | 600.0 | 277.1 | 186.2 | 109.5 | 1.07 | 1.24 | 0.35 | 246.3 | 46.7 | 19.0 | 83.1 | 0.06 |
| LR | 3.30 | 0.0 | 277.0 | 203.9 | 77.8 | 1.15 | 1.40 | 0.39 | 251.3 | 0.0 | 0.0 | 78.9 | 0.00 |
| PUT | 3.30 | 0.0 | 277.0 | 203.9 | 77.8 | 1.15 | 1.40 | 0.39 | 251.3 | 0.0 | 0.0 | 78.9 | 0.00 |

LRA=LOCKED ROTOR AMPS BDT =BREAKDOWN TORQUE MT=MAX TORQUE
 LRT=LOCKED ROTOR TORQUE NP RPM=NAMEPLATE RPM

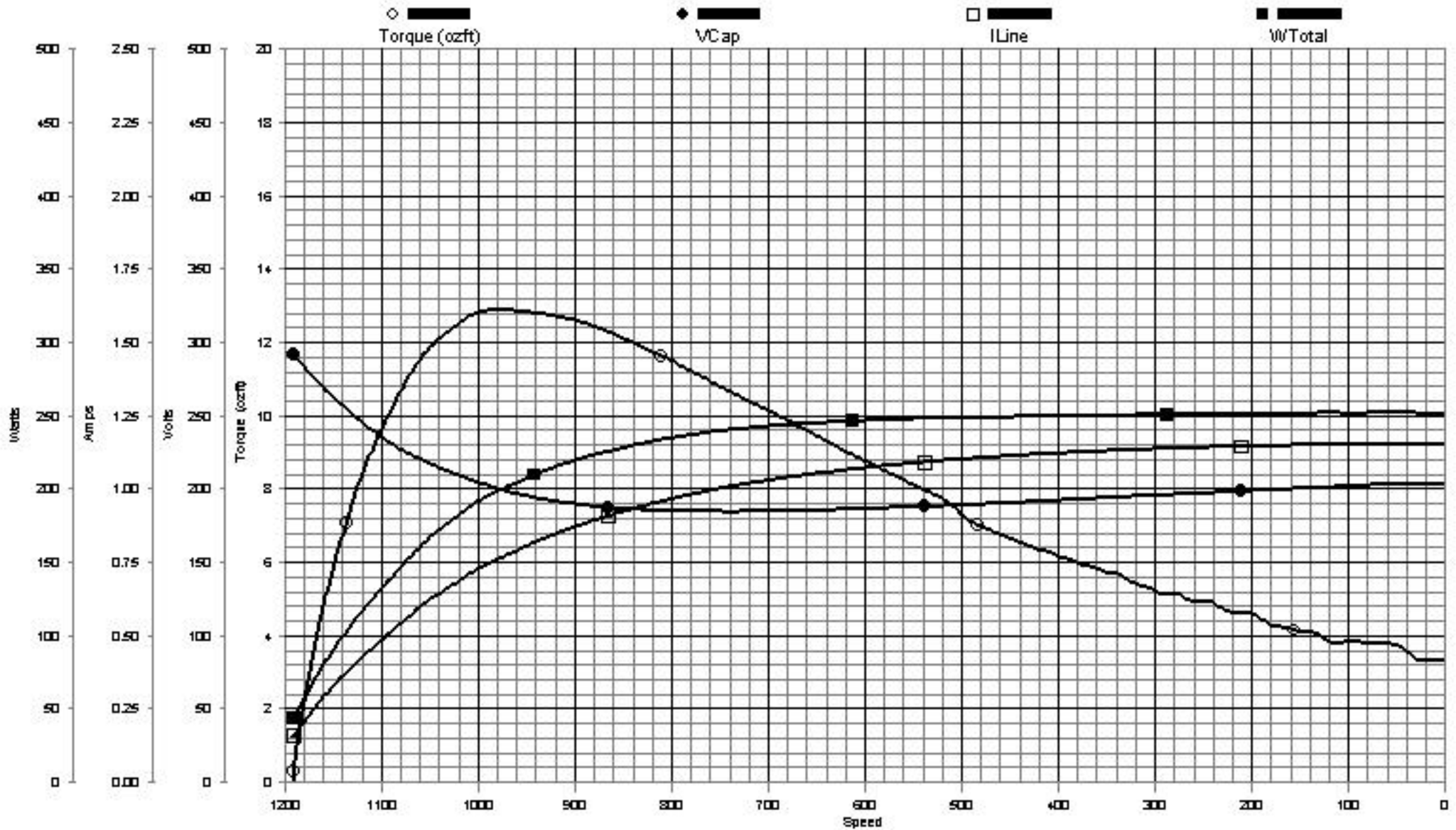

TRACKING #: 10053995
 SBU: Heating & Air Cond
 ENGINEER: JAMES PENG
 TECHNICIAN: DAN THOMPSON
 TORQUE CELL: 250-1 inlb
 NP RPM: 1075
 # SPEEDS: 3
 MOTOR #: 1
 COMMENT 2:

CUSTOMER: DISTRIBUTION SERVICES
 MODEL: 0603138B
 FRAME: 48
 PHASES: 1
 VOLTS: 277.0
 HERTZ: 60
 RUN CAP: 5.00
 COMMENT 1:
 COMMENT 3:

DESCRIPTION: SYNC-0
 TYPE: PSC
 BENCH: 1
 HP: 0.25
 ROTATION: CW
 EDT: 12.90
 LRA: 1.15
 LET: 3.20
 COMMENT 4:

Manual Test Results For 0603138

(High Speed)

12-19-2006

05:53 am

| | | |
|--------------------------|---------------------------------|-------------------|
| TRACKING #: 10053995 | CUSTOMER: DISTRIBUTION SERVICES | DESCRIPTION: IDLE |
| SBU: Heating & Air Cond | MODEL: 0603138B | TYPE: PSC |
| ENGINEER: JAMES PENG | FRAME: 48 | BENCH: 1 |
| TECHNICIAN: DAN THOMPSON | PHASES: 1 | HP: 0.25 |
| TORQUE CELL: 250-1 inlb | VOLTS: 277.0 | ROTATION: CW |
| NP RPM: 1075 | HERTZ: 60 | BDT: 0.00 |
| # SPEEDS: 3 | RUN CAP: 5.00 | LRA: 0.00 |
| MOTOR #: 1 | COMMENT1: | LRT: 0.00 |
| COMMENT 2: | COMMENT 3: | COMMENT 4: |

Resistance:

| | | | |
|---------|--------|--------|----------|
| | Start | Main1 | |
| | 03-02 | 01-02 | |
| Spec | 10.00 | 0.00 | |
| Results | 81.003 | 35.123 | @23.6 °C |

| VLine | VStart | VCap | ILine | IMain | IStart | WLine | TC01 | TC02 | TC03 | TC04 | Time |
|-------|--------|-------|-------|-------|--------|-------|------|------|------|------|-------------|
| 277.2 | 267.0 | 416.0 | 0.33 | 0.74 | 0.79 | 84.5 | OPEN | OPEN | OPEN | OPEN | 05:52:45 am |
| 229.9 | 225.7 | 348.5 | 0.25 | 0.56 | 0.66 | 57.8 | OPEN | OPEN | OPEN | OPEN | 05:53:01 am |

TRACKING #: 10053995
 SBU: Heating & Air Cond
 ENGINEER: JAMES PENG
 TECHNICIAN: DAN THOMPSON
 TORQUE CELL: 250-1 inlb
 NP RPM: 1075
 # SPEEDS: 3
 MOTOR #: 1
 COMMENT 2:

CUSTOMER: DISTRIBUTION SERVICES
 MODEL: 0603138B
 FRAME: 48
 PHASES: 1
 VOLTS: 277.0
 HERTZ: 60
 RUN CAP: 5.00
 COMMENT1:
 COMMENT 3:

DESCRIPTION: SYNC-0
 TYPE: PSC
 BENCH: 1
 HP: 0.25
 ROTATION: CW
 BDT: 26.02
 LRA: 2.30
 LRT: 7.34
 COMMENT 4:

Resistance:

Friction: -1.0156 ozft @ 200 RPM
 Friction + Wind: -1.2607 ozft @ 1080 RPM
 Inertia: 0.0192 ozft

| | | | |
|--------|--------|--------|----------|
| | Start | Main1 | |
| | 03-02 | 01-02 | |
| Spec | 10.00 | 0.00 | |
| Before | 81.240 | 35.219 | @24.1 °C |
| After | 82.004 | 35.733 | @23.8 °C |

Down Results (Torque In ozft):

| % Load | Torque | RPM | VLine | VCap | VStart | ILine | IMain | IStart | WLine | WOut | % Eff | % PF | HP |
|--------|--------|--------|-------|-------|--------|-------|-------|--------|-------|-------|-------|------|------|
| NL | 0.00 | 1193.3 | 277.4 | 417.8 | 265.6 | 0.32 | 0.75 | 0.80 | 82.7 | 0.0 | 0.0 | 93.2 | 0.00 |
| NP+100 | 5.71 | 1175.0 | 276.7 | 402.3 | 257.0 | 0.46 | 0.66 | 0.77 | 126.3 | 59.5 | 47.1 | 99.2 | 0.08 |
| NP+80 | 10.48 | 1155.0 | 276.5 | 386.1 | 246.6 | 0.62 | 0.65 | 0.73 | 169.3 | 107.4 | 63.4 | 98.8 | 0.14 |
| NP+60 | 14.38 | 1135.0 | 276.8 | 371.5 | 236.4 | 0.76 | 0.70 | 0.71 | 209.1 | 144.8 | 69.3 | 99.4 | 0.19 |
| NP-50* | 16.09 | 1125.0 | 277.1 | 365.0 | 231.4 | 0.83 | 0.75 | 0.69 | 228.0 | 160.6 | 70.5 | 99.1 | 0.22 |
| NP+40 | 17.62 | 1115.0 | 277.2 | 358.3 | 226.2 | 0.89 | 0.79 | 0.68 | 245.4 | 174.3 | 71.0 | 99.5 | 0.23 |
| NP-25* | 19.53 | 1100.0 | 277.0 | 348.8 | 218.4 | 0.98 | 0.87 | 0.66 | 269.1 | 190.6 | 70.8 | 99.1 | 0.26 |
| NP+20 | 20.08 | 1095.0 | 276.9 | 345.8 | 215.8 | 1.01 | 0.90 | 0.66 | 276.5 | 195.1 | 70.6 | 98.9 | 0.26 |
| FL | 20.71 | 1089.0 | 276.8 | 342.3 | 212.8 | 1.05 | 0.94 | 0.65 | 285.1 | 200.1 | 70.2 | 98.1 | 0.27 |
| NP | 22.09 | 1075.0 | 276.9 | 334.7 | 205.6 | 1.12 | 1.02 | 0.64 | 304.9 | 210.7 | 69.1 | 98.3 | 0.28 |
| NP-20 | 23.67 | 1055.0 | 277.6 | 326.1 | 196.5 | 1.23 | 1.14 | 0.62 | 331.7 | 221.6 | 66.8 | 97.1 | 0.30 |
| NP+25* | 24.01 | 1050.0 | 278.0 | 324.4 | 194.4 | 1.25 | 1.16 | 0.62 | 338.1 | 223.7 | 66.2 | 97.3 | 0.30 |
| NP-40 | 24.90 | 1035.0 | 278.6 | 319.3 | 188.3 | 1.32 | 1.25 | 0.61 | 355.9 | 228.7 | 64.3 | 96.8 | 0.31 |
| NP+50* | 25.32 | 1025.0 | 278.7 | 315.8 | 184.1 | 1.36 | 1.30 | 0.60 | 366.0 | 230.3 | 62.9 | 96.6 | 0.31 |
| NP-60 | 25.63 | 1015.0 | 278.6 | 312.3 | 179.8 | 1.40 | 1.34 | 0.59 | 374.9 | 230.9 | 61.6 | 96.1 | 0.31 |
| NP-80 | 25.89 | 995.0 | 277.6 | 305.4 | 171.3 | 1.47 | 1.43 | 0.58 | 389.1 | 228.6 | 58.8 | 95.4 | 0.31 |
| NP-100 | 25.99 | 975.0 | 277.2 | 300.1 | 163.6 | 1.54 | 1.52 | 0.57 | 402.3 | 224.9 | 55.9 | 94.2 | 0.30 |
| BDT | 26.02 | 966.2 | 277.1 | 298.2 | 160.5 | 1.56 | 1.55 | 0.57 | 408.0 | 223.1 | 54.7 | 94.4 | 0.30 |
| MT | 26.02 | 966.2 | 277.1 | 298.2 | 160.5 | 1.56 | 1.55 | 0.57 | 408.0 | 223.1 | 54.7 | 94.4 | 0.30 |
| NP-200 | 24.99 | 875.0 | 277.1 | 285.5 | 132.8 | 1.79 | 1.86 | 0.54 | 451.5 | 194.0 | 43.0 | 91.0 | 0.26 |
| NP-300 | 22.44 | 775.0 | 276.9 | 280.9 | 110.7 | 1.96 | 2.09 | 0.53 | 476.5 | 154.3 | 32.4 | 87.8 | 0.21 |
| NP-400 | 19.52 | 675.0 | 276.6 | 280.9 | 94.3 | 2.07 | 2.25 | 0.53 | 489.6 | 116.9 | 23.9 | 85.5 | 0.16 |
| HS | 17.65 | 600.0 | 277.7 | 283.5 | 85.5 | 2.14 | 2.35 | 0.54 | 500.0 | 94.0 | 18.8 | 84.1 | 0.13 |
| PUT | 7.10 | 31.8 | 277.3 | 305.5 | 54.6 | 2.30 | 2.63 | 0.58 | 511.1 | 2.0 | 0.4 | 80.1 | 0.00 |
| LR | 7.34 | 0.0 | 277.7 | 306.0 | 54.4 | 2.30 | 2.62 | 0.58 | 511.9 | 0.0 | 0.0 | 80.1 | 0.00 |

LRA=LOCKED ROTOR AMPS BDT =BREAKDOWN TORQUE MT=MAX TORQUE
 LRT=LOCKED ROTOR TORQUE NP RPM=NAMEPLATE RPM

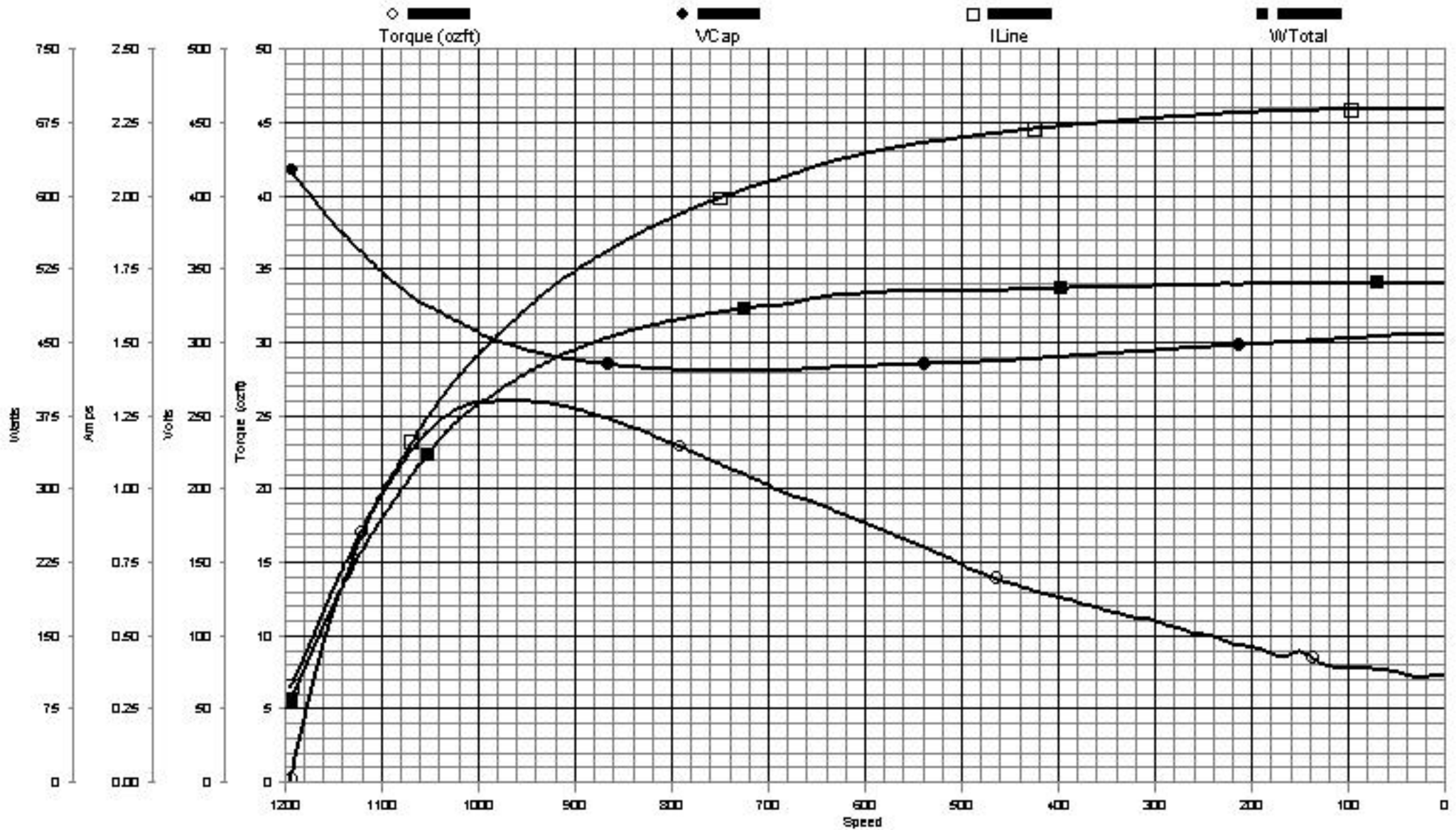

TRACKING #: 10053995
 SBU: Heating & Air Cond
 ENGINEER: JAMES PENG
 TECHNICIAN: DAN THOMPSON
 TORQUE CELL: 250-1 inlb
 NP RPM: 1075
 # SPEEDS: 3
 MOTOR #: 1
 COMMENT 2:

CUSTOMER: DISTRIBUTION SERVICES
 MODEL: 0603138B
 FRAME: 48
 PHASES: 1
 VOLTS: 277.0
 HERTZ: 60
 RUN CAP: 5.00
 COMMENT 1:
 COMMENT 3:

DESCRIPTION: SYNC-0
 TYPE: PSC
 BENCH: 1
 HP: 0.25
 ROTATION: CW
 EDT: 26.02
 LRA: 2.30
 LET: 7.34
 COMMENT 4:

TRACKING #: 10053995
 SBU: Heating & Air Cond
 ENGINEER: JAMES PENG
 TECHNICIAN: DAN THOMPSON
 TORQUE CELL: 250-1 inlb
 NP RPM: 1075
 # SPEEDS: 3
 MOTOR #: 1
 COMMENT 2:

CUSTOMER: DISTRIBUTION SERVICES
 MODEL: 0603138B
 FRAME: 48
 PHASES: 1
 VOLTS: 230.0
 HERTZ: 60
 RUN CAP: 5.00
 COMMENT1:
 COMMENT 3:

DESCRIPTION: SYNC-0
 TYPE: PSC
 BENCH: 1
 HP: 0.25
 ROTATION: CW
 BDT: 11.72
 LRA: 1.24
 LRT: 3.04
 COMMENT 4:

Resistance:

Friction: -0.8939 ozft @ 200 RPM
 Friction + Wind: -1.2025 ozft @ 1080 RPM
 Inertia: 0.0180 ozft

| | Start | Main1 | |
|--------|--------|--------|----------|
| | 03-02 | 01-02 | |
| Spec | 10.00 | 0.00 | |
| Before | 81.009 | 54.993 | @22.9 °C |
| After | 81.303 | 55.260 | @22.8 °C |

Down Results (Torque In ozft):

| % Load | Torque | RPM | VLine | VCap | VStart | ILine | IMain | IStart | WLine | WOut | % Eff | % PF | HP |
|--------|--------|--------|-------|-------|--------|-------|-------|--------|-------|-------|-------|-------|------|
| NL | 0.00 | 1190.8 | 230.2 | 280.0 | 182.7 | 0.17 | 0.44 | 0.53 | 39.2 | 0.0 | 0.0 | 100.0 | 0.00 |
| NP+100 | 2.86 | 1175.0 | 230.0 | 269.1 | 178.3 | 0.25 | 0.40 | 0.51 | 58.1 | 29.8 | 51.3 | 100.0 | 0.04 |
| NP+80 | 5.05 | 1155.0 | 229.9 | 256.4 | 172.2 | 0.34 | 0.38 | 0.49 | 77.8 | 51.8 | 66.5 | 99.5 | 0.07 |
| NP+60 | 6.75 | 1135.0 | 229.8 | 244.7 | 166.0 | 0.41 | 0.40 | 0.46 | 94.8 | 68.0 | 71.7 | 100.0 | 0.09 |
| NP-50* | 7.49 | 1125.0 | 229.8 | 239.3 | 163.0 | 0.45 | 0.42 | 0.45 | 102.6 | 74.8 | 72.9 | 99.2 | 0.10 |
| NP+40 | 8.14 | 1115.0 | 229.7 | 234.3 | 160.0 | 0.48 | 0.45 | 0.45 | 110.1 | 80.5 | 73.2 | 99.9 | 0.11 |
| NP-25* | 8.96 | 1100.0 | 229.7 | 227.4 | 155.6 | 0.53 | 0.49 | 0.43 | 120.7 | 87.5 | 72.5 | 99.1 | 0.12 |
| NP+20 | 9.20 | 1095.0 | 229.6 | 225.3 | 154.2 | 0.55 | 0.50 | 0.43 | 124.0 | 89.4 | 72.1 | 98.2 | 0.12 |
| NP | 10.08 | 1075.0 | 229.9 | 217.6 | 148.7 | 0.61 | 0.56 | 0.41 | 137.2 | 96.2 | 70.1 | 97.8 | 0.13 |
| NP-20 | 10.72 | 1055.0 | 230.0 | 210.9 | 143.5 | 0.66 | 0.62 | 0.40 | 148.5 | 100.4 | 67.6 | 97.8 | 0.13 |
| NP+25* | 10.84 | 1050.0 | 230.0 | 209.4 | 142.1 | 0.68 | 0.64 | 0.40 | 150.9 | 101.0 | 66.9 | 96.5 | 0.14 |
| NP-40 | 11.13 | 1035.0 | 229.9 | 205.1 | 138.3 | 0.71 | 0.68 | 0.39 | 157.8 | 102.2 | 64.8 | 96.7 | 0.14 |
| NP+50* | 11.31 | 1025.0 | 230.0 | 202.7 | 135.9 | 0.74 | 0.71 | 0.39 | 162.3 | 102.9 | 63.4 | 95.4 | 0.14 |
| NP-60 | 11.46 | 1015.0 | 230.3 | 200.6 | 133.6 | 0.76 | 0.74 | 0.38 | 166.7 | 103.2 | 61.9 | 95.2 | 0.14 |
| NP-80 | 11.65 | 995.0 | 230.5 | 196.6 | 129.1 | 0.80 | 0.79 | 0.37 | 174.5 | 102.9 | 58.9 | 94.6 | 0.14 |
| NP-100 | 11.71 | 975.0 | 230.5 | 193.2 | 124.7 | 0.84 | 0.84 | 0.37 | 180.8 | 101.3 | 56.0 | 93.4 | 0.14 |
| MT | 11.72 | 965.4 | 230.5 | 191.7 | 122.7 | 0.85 | 0.86 | 0.36 | 183.5 | 100.4 | 54.7 | 93.7 | 0.13 |
| BDT | 11.72 | 965.4 | 230.5 | 191.7 | 122.7 | 0.85 | 0.86 | 0.36 | 183.5 | 100.4 | 54.7 | 93.7 | 0.13 |
| NP-200 | 11.20 | 875.0 | 230.1 | 182.7 | 105.9 | 0.97 | 1.03 | 0.35 | 201.8 | 87.0 | 43.1 | 90.4 | 0.12 |
| NP-300 | 10.04 | 775.0 | 230.1 | 179.8 | 91.7 | 1.06 | 1.16 | 0.34 | 212.3 | 69.0 | 32.5 | 87.0 | 0.09 |
| NP-400 | 8.78 | 675.0 | 230.0 | 180.2 | 80.8 | 1.12 | 1.26 | 0.34 | 217.6 | 52.6 | 24.2 | 84.5 | 0.07 |
| HS | 7.92 | 600.0 | 230.1 | 181.5 | 74.2 | 1.15 | 1.31 | 0.35 | 220.1 | 42.2 | 19.2 | 83.2 | 0.06 |
| PUT | 2.99 | 31.0 | 230.3 | 198.0 | 42.0 | 1.24 | 1.48 | 0.38 | 224.7 | 0.8 | 0.4 | 78.7 | 0.00 |
| LR | 3.04 | 0.0 | 230.1 | 197.8 | 41.8 | 1.24 | 1.48 | 0.38 | 223.7 | 0.0 | 0.0 | 78.4 | 0.00 |

LRA=LOCKED ROTOR AMPS BDT =BREAKDOWN TORQUE MT=MAX TORQUE
 LRT=LOCKED ROTOR TORQUE NP RPM=NAMEPLATE RPM

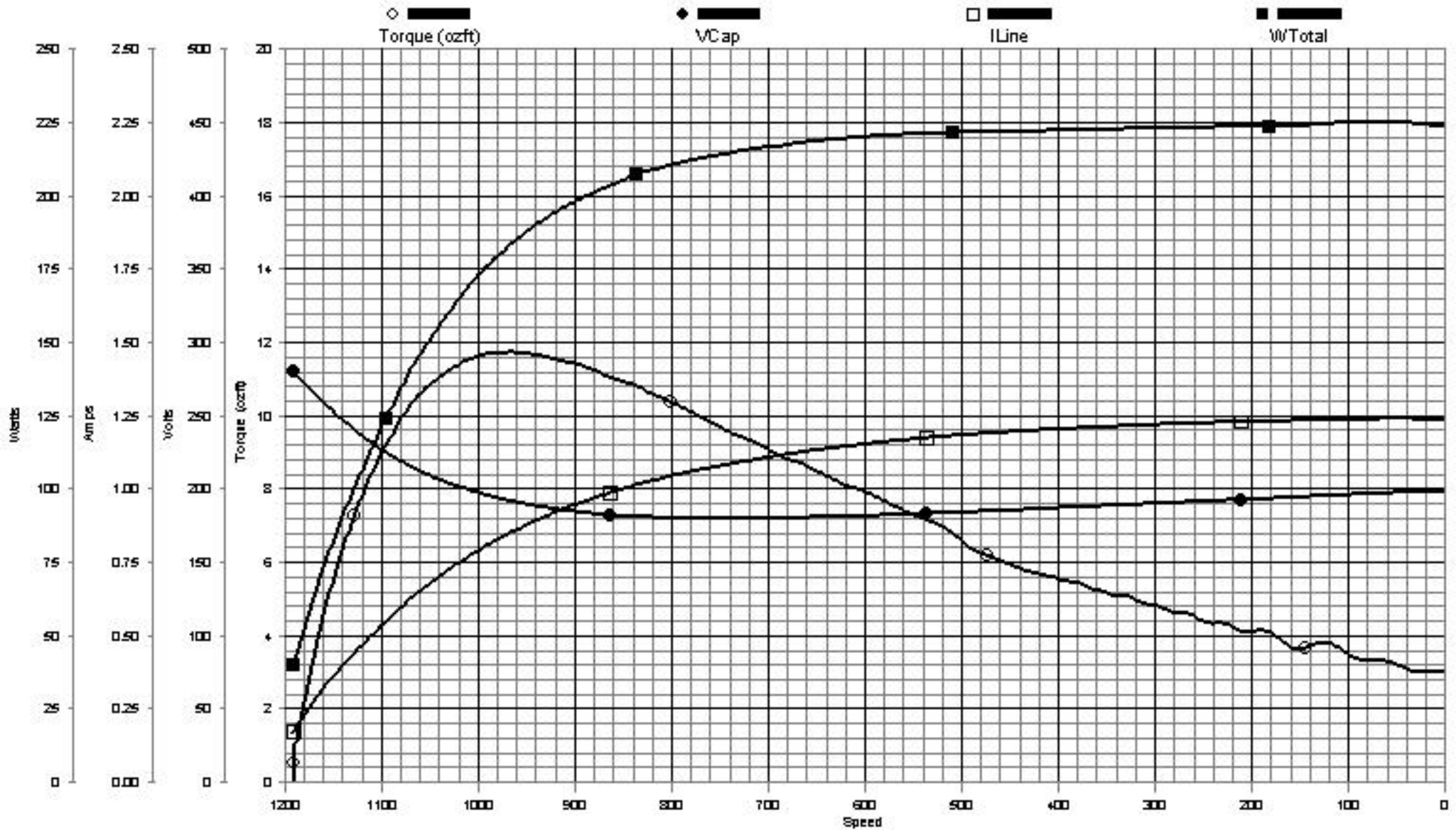

TRACKING #: 10053995
 SBU: Heating & Air Cond
 ENGINEER: JAMES PENG
 TECHNICIAN: DAN THOMPSON
 TORQUE CELL: 250-1 inlb
 NP RPM: 1075
 # SPEEDS: 3
 MOTOR #: 1
 COMMENT 2:

CUSTOMER: DISTRIBUTION SERVICES
 MODEL: 0603138B
 FRAME: 48
 PHASES: 1
 VOLTS: 230.0
 HERTZ: 60
 RUN CAP: 5.00
 COMMENT 1:
 COMMENT 3:

DESCRIPTION: SYNC-0
 TYPE: PSC
 BENCH: 1
 HP: 0.25
 ROTATION: CW
 EDT: 11.72
 LRA: 1.24
 LET: 3.04
 COMMENT 4:

TRACKING #: 10053995
 SBU: Heating & Air Cond
 ENGINEER: JAMES PENG
 TECHNICIAN: DAN THOMPSON
 TORQUE CELL: 250-1 inlb
 NP RPM: 1075
 # SPEEDS: 3
 MOTOR #: 1
 COMMENT 2:

CUSTOMER: DISTRIBUTION SERVICES
 MODEL: 0603138B
 FRAME: 48
 PHASES: 1
 VOLTS: 230.0
 HERTZ: 60
 RUN CAP: 5.00
 COMMENT1:
 COMMENT 3:

DESCRIPTION: SYNC-0
 TYPE: PSC
 BENCH: 1
 HP: 0.25
 ROTATION: CW
 BDT: 9.02
 LRA: 0.95
 LRT: 2.07
 COMMENT 4:

Resistance:

| | Start | Main1 | |
|--------|--------|--------|----------|
| | 03-02 | 01-02 | |
| Spec | 10.00 | 0.00 | |
| Before | 80.962 | 70.761 | @22.9 °C |
| After | 81.112 | 70.982 | @22.8 °C |

Friction: -1.0016 ozft @ 200 RPM
 Friction + Wind: -1.1828 ozft @ 1080 RPM
 Inertia: 0.0182 ozft

Down Results (Torque In ozft):

| % Load | Torque | RPM | VLine | VCap | VStart | ILine | IMain | IStart | WLine | WOut | % Eff | % PF | HP |
|--------|--------|--------|-------|-------|--------|-------|-------|--------|-------|------|-------|-------|------|
| NL | 0.00 | 1192.1 | 229.8 | 242.8 | 167.0 | 0.13 | 0.39 | 0.46 | 29.0 | 0.0 | 0.0 | 97.1 | 0.00 |
| NP+100 | 2.26 | 1175.0 | 230.0 | 232.6 | 164.2 | 0.19 | 0.35 | 0.44 | 44.1 | 23.6 | 53.4 | 100.0 | 0.03 |
| NP+80 | 3.94 | 1155.0 | 229.9 | 221.2 | 160.5 | 0.26 | 0.33 | 0.42 | 59.6 | 40.4 | 67.8 | 99.7 | 0.05 |
| NP+60 | 5.24 | 1135.0 | 229.8 | 210.9 | 156.7 | 0.32 | 0.33 | 0.40 | 73.0 | 52.8 | 72.3 | 99.3 | 0.07 |
| NP-50* | 5.78 | 1125.0 | 229.8 | 206.2 | 154.9 | 0.35 | 0.34 | 0.39 | 78.9 | 57.7 | 73.1 | 98.1 | 0.08 |
| NP+40 | 6.27 | 1115.0 | 229.7 | 201.8 | 153.0 | 0.37 | 0.36 | 0.38 | 84.2 | 62.0 | 73.7 | 99.1 | 0.08 |
| NP-25* | 6.90 | 1100.0 | 229.7 | 195.8 | 150.2 | 0.41 | 0.39 | 0.37 | 91.9 | 67.4 | 73.3 | 97.6 | 0.09 |
| NP+20 | 7.08 | 1095.0 | 229.8 | 193.9 | 149.3 | 0.42 | 0.40 | 0.37 | 94.4 | 68.8 | 72.9 | 97.8 | 0.09 |
| NP | 7.71 | 1075.0 | 229.7 | 186.9 | 145.4 | 0.46 | 0.44 | 0.36 | 103.9 | 73.5 | 70.8 | 98.3 | 0.10 |
| NP-20 | 8.23 | 1055.0 | 230.1 | 181.2 | 142.0 | 0.50 | 0.49 | 0.34 | 112.5 | 77.0 | 68.5 | 97.8 | 0.10 |
| NP+25* | 8.33 | 1050.0 | 230.1 | 179.8 | 141.1 | 0.51 | 0.50 | 0.34 | 114.5 | 77.6 | 67.8 | 97.6 | 0.10 |
| NP-40 | 8.58 | 1035.0 | 230.1 | 176.1 | 138.4 | 0.54 | 0.53 | 0.33 | 119.9 | 78.8 | 65.7 | 96.5 | 0.11 |
| NP+50* | 8.71 | 1025.0 | 230.1 | 173.9 | 136.7 | 0.56 | 0.55 | 0.33 | 123.3 | 79.2 | 64.3 | 95.7 | 0.11 |
| NP-60 | 8.83 | 1015.0 | 230.2 | 171.9 | 135.1 | 0.58 | 0.57 | 0.33 | 126.5 | 79.5 | 62.9 | 94.7 | 0.11 |
| NP-80 | 8.96 | 995.0 | 230.4 | 168.4 | 131.9 | 0.61 | 0.61 | 0.32 | 132.2 | 79.1 | 59.8 | 94.1 | 0.11 |
| NP-100 | 9.01 | 975.0 | 230.4 | 165.3 | 128.7 | 0.64 | 0.65 | 0.31 | 137.0 | 78.0 | 56.9 | 92.9 | 0.10 |
| MT | 9.02 | 967.8 | 230.4 | 164.3 | 127.6 | 0.64 | 0.66 | 0.31 | 138.6 | 77.5 | 55.9 | 94.0 | 0.10 |
| BDT | 9.02 | 967.8 | 230.4 | 164.3 | 127.6 | 0.64 | 0.66 | 0.31 | 138.6 | 77.5 | 55.9 | 94.0 | 0.10 |
| NP-200 | 8.63 | 875.0 | 230.1 | 155.9 | 114.7 | 0.74 | 0.80 | 0.30 | 153.2 | 67.0 | 43.7 | 90.0 | 0.09 |
| NP-300 | 7.77 | 775.0 | 230.1 | 153.4 | 103.9 | 0.81 | 0.91 | 0.29 | 161.7 | 53.4 | 33.0 | 86.8 | 0.07 |
| NP-400 | 6.84 | 675.0 | 230.0 | 153.9 | 95.3 | 0.86 | 0.98 | 0.29 | 166.0 | 41.0 | 24.7 | 83.9 | 0.05 |
| HS | 6.15 | 600.0 | 230.0 | 155.0 | 90.0 | 0.88 | 1.02 | 0.29 | 167.9 | 32.7 | 19.5 | 83.0 | 0.04 |
| LR | 2.07 | 0.0 | 229.9 | 170.0 | 63.8 | 0.95 | 1.16 | 0.32 | 171.2 | 0.0 | 0.0 | 78.4 | 0.00 |
| PUT | 2.07 | 0.0 | 229.9 | 170.0 | 63.8 | 0.95 | 1.16 | 0.32 | 171.2 | 0.0 | 0.0 | 78.4 | 0.00 |

LRA=LOCKED ROTOR AMPS BDT =BREAKDOWN TORQUE MT=MAX TORQUE
 LRT=LOCKED ROTOR TORQUE NP RPM=NAMEPLATE RPM

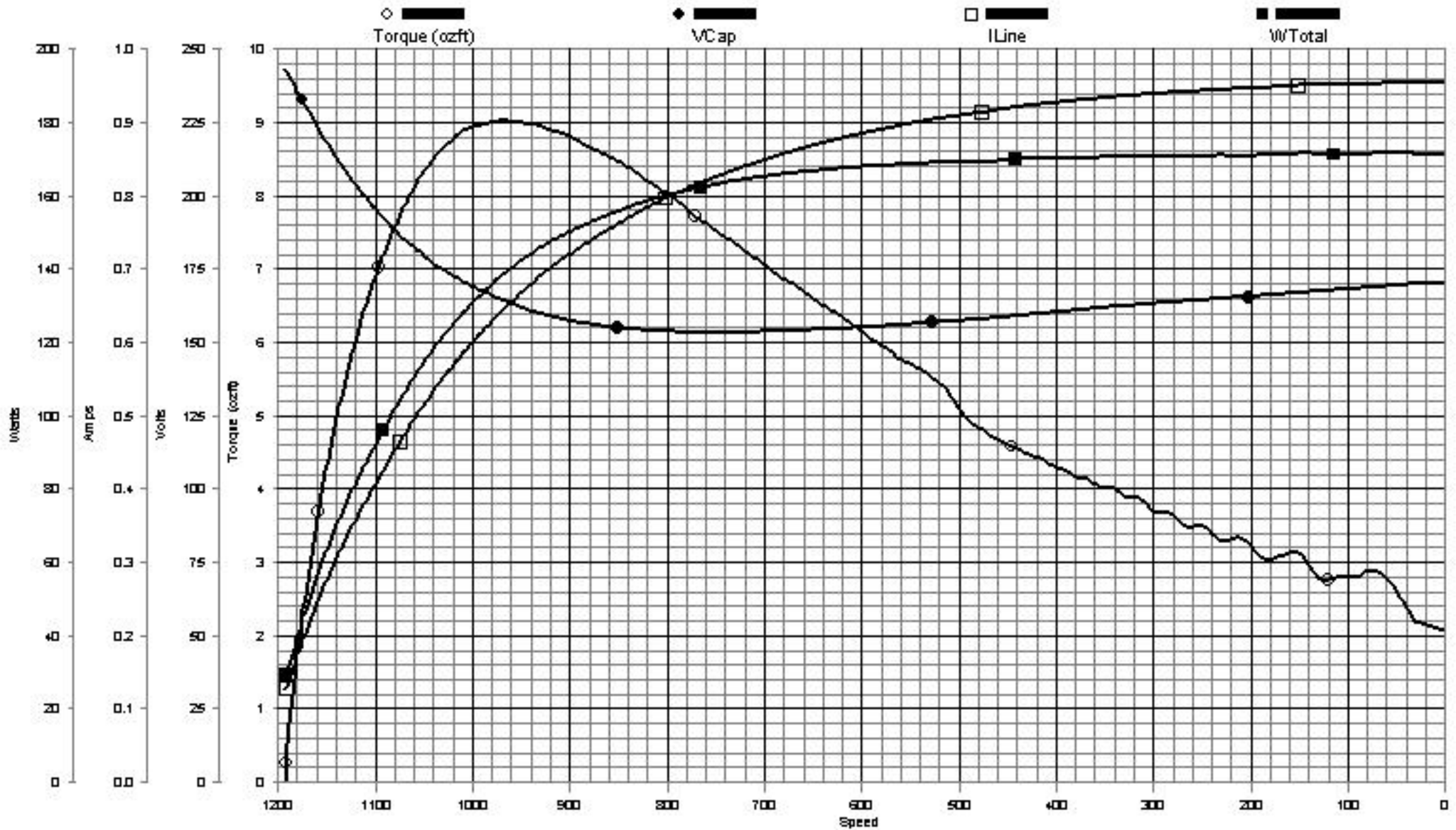

TRACKING #: 10053995
 SBU: Heating & Air Cond
 ENGINEER: JAMES PENG
 TECHNICIAN: DAN THOMPSON
 TORQUE CELL: 250-1 inlb
 NP RPM: 1075
 # SPEEDS: 3
 MOTOR #: 1
 COMMENT 2:

CUSTOMER: DISTRIBUTION SERVICES
 MODEL: 0603138B
 FRAME: 48
 PHASES: 1
 VOLTS: 230.0
 HERTZ: 60
 RUN CAP: 5.00
 COMMENT 1:
 COMMENT 3:

DESCRIPTION: SYNC-0
 TYPE: PSC
 BENCH: 1
 HP: 0.25
 ROTATION: CW
 EDT: 9.02
 LRA: 0.95
 LET: 2.07
 COMMENT 4:

TRACKING #: 10053995
 SBU: Heating & Air Cond
 ENGINEER: JAMES PENG
 TECHNICIAN: DAN THOMPSON
 TORQUE CELL: 250-1 inlb
 NP RPM: 1075
 # SPEEDS: 3
 MOTOR #: 1
 COMMENT 2:

CUSTOMER: DISTRIBUTION SERVICES
 MODEL: 0603138B
 FRAME: 48
 PHASES: 1
 VOLTS: 230.0
 HERTZ: 60
 RUN CAP: 5.00
 COMMENT1:
 COMMENT 3:

DESCRIPTION: SYNC-0
 TYPE: PSC
 BENCH: 1
 HP: 0.25
 ROTATION: CW
 BDT: 17.94
 LRA: 1.88
 LRT: 4.68
 COMMENT 4:

Resistance:

Friction: -0.9333 ozft @ 200 RPM
 Friction + Wind: -1.2308 ozft @ 1080 RPM
 Inertia: 0.0174 ozft

| | Start | Main1 | |
|--------|--------|--------|----------|
| | 03-02 | 01-02 | |
| Spec | 10.00 | 0.00 | |
| Before | 81.073 | 35.138 | @23.1 °C |
| After | 81.552 | 35.466 | @23.0 °C |

Down Results (Torque In ozft):

| % Load | Torque | RPM | VLine | VCap | VStart | ILine | IMain | IStart | WLine | WOut | % Eff | % PF | HP |
|--------|--------|--------|-------|-------|--------|-------|-------|--------|-------|-------|-------|-------|------|
| NL | 0.00 | 1192.2 | 230.2 | 349.2 | 224.4 | 0.26 | 0.56 | 0.66 | 59.2 | 0.0 | 0.0 | 98.9 | 0.00 |
| NP+100 | 4.12 | 1175.0 | 229.9 | 336.5 | 216.7 | 0.38 | 0.51 | 0.64 | 86.8 | 43.0 | 49.5 | 99.4 | 0.06 |
| NP+80 | 7.47 | 1155.0 | 229.8 | 322.1 | 207.1 | 0.51 | 0.51 | 0.61 | 116.5 | 76.6 | 65.7 | 99.4 | 0.10 |
| NP+60 | 10.14 | 1135.0 | 229.7 | 308.7 | 197.4 | 0.63 | 0.56 | 0.59 | 143.8 | 102.1 | 71.0 | 99.4 | 0.14 |
| NP-50* | 11.27 | 1125.0 | 229.7 | 302.6 | 192.8 | 0.68 | 0.60 | 0.58 | 156.3 | 112.5 | 72.0 | 100.0 | 0.15 |
| NP+40 | 12.32 | 1115.0 | 229.8 | 297.1 | 188.3 | 0.74 | 0.64 | 0.56 | 168.3 | 121.9 | 72.4 | 99.0 | 0.16 |
| NP-25* | 13.65 | 1100.0 | 229.9 | 289.3 | 181.7 | 0.81 | 0.72 | 0.55 | 185.2 | 133.2 | 71.9 | 99.5 | 0.18 |
| NP+20 | 14.04 | 1095.0 | 229.9 | 286.8 | 179.6 | 0.84 | 0.74 | 0.55 | 190.4 | 136.4 | 71.7 | 98.6 | 0.18 |
| NP | 15.39 | 1075.0 | 229.9 | 277.6 | 170.9 | 0.93 | 0.84 | 0.53 | 210.4 | 146.8 | 69.8 | 98.4 | 0.20 |
| NP-20 | 16.39 | 1055.0 | 230.0 | 269.7 | 162.7 | 1.02 | 0.94 | 0.51 | 227.7 | 153.4 | 67.4 | 97.1 | 0.21 |
| NP+25* | 16.58 | 1050.0 | 230.0 | 267.9 | 160.7 | 1.03 | 0.96 | 0.51 | 231.5 | 154.5 | 66.7 | 97.7 | 0.21 |
| NP-40 | 17.09 | 1035.0 | 230.2 | 263.1 | 155.2 | 1.09 | 1.02 | 0.50 | 242.2 | 157.0 | 64.8 | 96.5 | 0.21 |
| NP+50* | 17.37 | 1025.0 | 230.3 | 260.3 | 151.7 | 1.12 | 1.07 | 0.49 | 248.9 | 158.0 | 63.5 | 96.5 | 0.21 |
| NP-60 | 17.59 | 1015.0 | 230.4 | 257.8 | 148.4 | 1.15 | 1.11 | 0.49 | 255.2 | 158.4 | 62.1 | 96.3 | 0.21 |
| NP-80 | 17.83 | 995.0 | 230.5 | 253.1 | 141.8 | 1.22 | 1.18 | 0.48 | 266.5 | 157.4 | 59.1 | 94.8 | 0.21 |
| NP-100 | 17.92 | 975.0 | 230.3 | 248.8 | 135.4 | 1.27 | 1.25 | 0.47 | 275.7 | 155.0 | 56.2 | 94.3 | 0.21 |
| MT | 17.94 | 965.7 | 230.2 | 247.1 | 132.6 | 1.29 | 1.28 | 0.47 | 279.5 | 153.7 | 55.0 | 94.1 | 0.21 |
| BDT | 17.94 | 965.7 | 230.2 | 247.1 | 132.6 | 1.29 | 1.28 | 0.47 | 279.5 | 153.7 | 55.0 | 94.1 | 0.21 |
| NP-200 | 17.11 | 875.0 | 230.0 | 236.7 | 109.6 | 1.48 | 1.54 | 0.45 | 307.8 | 132.9 | 43.2 | 90.4 | 0.18 |
| NP-300 | 15.32 | 775.0 | 229.8 | 233.1 | 91.0 | 1.61 | 1.72 | 0.44 | 323.9 | 105.4 | 32.5 | 87.5 | 0.14 |
| NP-400 | 13.42 | 675.0 | 230.2 | 233.9 | 77.9 | 1.71 | 1.86 | 0.44 | 333.7 | 80.4 | 24.1 | 84.8 | 0.11 |
| HS | 12.02 | 600.0 | 230.1 | 235.1 | 70.1 | 1.75 | 1.93 | 0.45 | 336.6 | 64.0 | 19.0 | 83.6 | 0.09 |
| LR | 4.68 | 0.0 | 229.9 | 254.2 | 45.4 | 1.88 | 2.16 | 0.48 | 343.9 | 0.0 | 0.0 | 79.6 | 0.00 |
| PUT | 4.68 | 0.0 | 229.9 | 254.2 | 45.4 | 1.88 | 2.16 | 0.48 | 343.9 | 0.0 | 0.0 | 79.6 | 0.00 |

LRA=LOCKED ROTOR AMPS BDT =BREAKDOWN TORQUE MT=MAX TORQUE
 LRT=LOCKED ROTOR TORQUE NP RPM=NAMEPLATE RPM

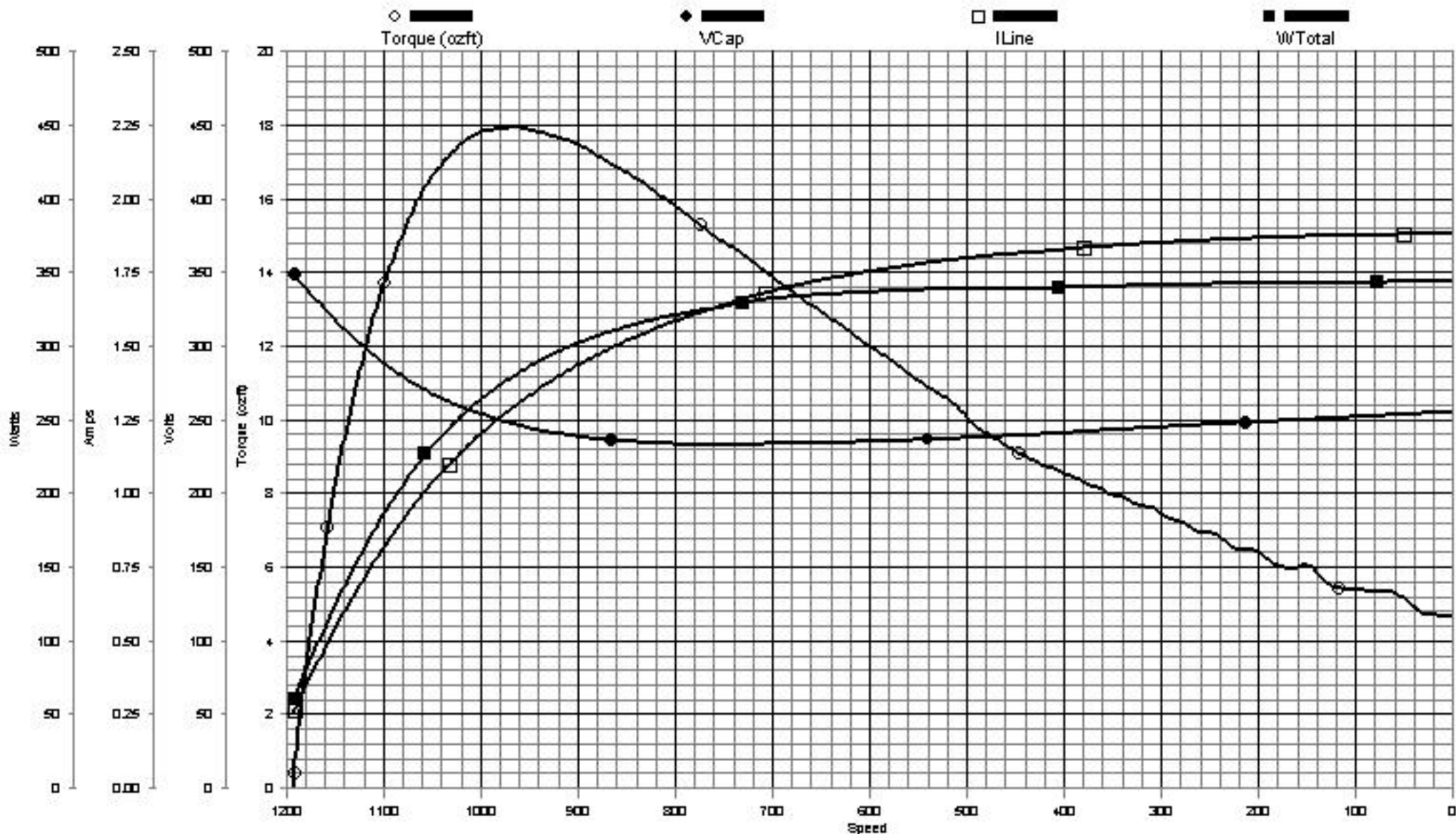

TRACKING #: 10053995
 SBU: Heating & Air Cond
 ENGINEER: JAMES PENG
 TECHNICIAN: DAN THOMPSON
 TORQUE CELL: 250-1 inlb
 NP RPM: 1075
 # SPEEDS: 3
 MOTOR #: 1
 COMMENT 2:

CUSTOMER: DISTRIBUTION SERVICES
 MODEL: 0603138B
 FRAME: 48
 PHASES: 1
 VOLTS: 230.0
 HERTZ: 60
 RUN CAP: 5.00
 COMMENT 1:
 COMMENT 3:

DESCRIPTION: SYNC-0
 TYPE: PSC
 BENCH: 1
 HP: 0.25
 ROTATION: CW
 EDT: 17.94
 LRA: 1.88
 LET: 4.68
 COMMENT 4:



Specification & Rating Report

Item Number: **9432A**

Specification Number: **1**

Model Number: **F48Y94A01**

Carton Label Model
Number:

Customer Model
Number:

Agency Type:

CE: **N**

CSA: **Y**

UL: **Y**

UL Explosion Proof Rating:

Sample Number:

Customer Specification
Number:

Catalog Number: **9432A**

CE Number:

CSA Number: **NO**

UL Number: **NO**

Cubic Feet Per Minute:

F2 Assembly:

UPC Model Number: **786674011275**

UPC Catalog Number: **786674011275**

Nameplate Drive
Bearing Type:

Nameplate Opposite
Drive Bearing Type:

Capacitor:

Capacitor Rating MFD: **5**

Control Code:

DC Design Number:

Form Factor:

Connection Diagram:

Lubrication Label
Diagram:

Outline Diagram: **9432A-S01**

Ambient Temperature: **60**

Label Drive Bearing **BALL**
Type:

Label Opposite Drive **BALL**
Bearing Type:

Capacitor Included: **N**

Capacitor Rating VAC: **370**

Design Status:

Features:

Installation Diagram:

Warning Label
Diagram:

Outline Graphic: **012A**

Insulation Class: **B**



Specification & Rating Report

| | |
|--------------------------------------------------------------------------------------------------------------------------------------------------------------------------------------------------------------------------------------------------------------------------------------------------------------------------------------------------------------------------------------------------------------------------------------------------------------------------------------------------------------------------------------------------------------------------------------------------------------------------------------------------------------------------------------------------------------------------------------------------------------------------------------------------------------------------------------------------------------------------------------------------------------------------------------------------------------------------------------------------------------------------------------------------------------------------------------------------------------------------------------------------------------------------------------------------------------------------------------------------------------------|----------------------------------------------------------------------------------------------------------------------------------------------------------------------------------------------------------------------------------------------------------------------------------------------------------------------------------------------------------------------------------------------------------------------------------------------------------|
| <p>Protector: AUTOMATIC</p> <p>Nameplate Overload:</p> <p style="padding-left: 20px;">IP Code:</p> <p>Nameplate Enclosure: OPEN</p> <p style="padding-left: 20px;">Frame Length: 3.63</p> <p style="padding-left: 20px;">Frame Diameter:</p> <p style="padding-left: 40px;">Frame Size: 48Y</p> <p style="padding-left: 20px;">Frame Material: ROLLED STEEL</p> <p>Operator Instruction Manual:</p> <p>Nameplate Mounting:</p> <p style="padding-left: 20px;">Base Height:</p> <p style="padding-left: 20px;">Ring Diameter:</p> <p style="padding-left: 40px;">Nameplate:</p> <p>Nameplate Location L Format:</p> <p style="padding-left: 40px;">Brake:</p> <p>Layer Quantity:</p> <p style="padding-left: 20px;">Phase: 1</p> <p style="padding-left: 20px;">DC Pole:</p> <p style="padding-left: 40px;">Poles: 6</p> <p style="padding-left: 20px;">Speeds: 3</p> <p style="padding-left: 40px;">Duty: AIR OVER</p> <p>Shaft Diameter: .5</p> <p>Shaft Extension: 5.5</p> <p>Shaft Material:</p> <p style="padding-left: 20px;">Shaft Type: FLAT</p> <p>Motor Type: UF</p> <p>Motor Use:</p> <p>Nameplate 1:</p> <p>Nameplate 2:</p> <p>Nameplate Text 1:</p> | <p>Thermal Protection:</p> <p>Label Overload:</p> <p>Label Enclosure: OPEN</p> <p>Frame Length UOM:</p> <p>Frame Diameter UOM:</p> <p>End Frame Material:</p> <p>Label Mounting: FLEX MOUNT</p> <p>Base Height UOM:</p> <p>RingDiameterUOM:</p> <p>Carton Label:</p> <p>Tachometer:</p> <p>Pallet Quantity:</p> <p>CurrentType:</p> <p>Shaft Diameter UOM: IN</p> <p>Shaft Extension UOM: IN</p> <p>Rotation: REV</p> |
|--------------------------------------------------------------------------------------------------------------------------------------------------------------------------------------------------------------------------------------------------------------------------------------------------------------------------------------------------------------------------------------------------------------------------------------------------------------------------------------------------------------------------------------------------------------------------------------------------------------------------------------------------------------------------------------------------------------------------------------------------------------------------------------------------------------------------------------------------------------------------------------------------------------------------------------------------------------------------------------------------------------------------------------------------------------------------------------------------------------------------------------------------------------------------------------------------------------------------------------------------------------------|----------------------------------------------------------------------------------------------------------------------------------------------------------------------------------------------------------------------------------------------------------------------------------------------------------------------------------------------------------------------------------------------------------------------------------------------------------|



Specification & Rating Report

Nameplate Text 2:

Nameplate Text 3:

Nameplate Text 4:

Label Text 1: **PERMANENT**

SPLIT

CAPACITOR

Label Text 2:

Label Text 3: **FLEXMOUNT BLOWER**

Label Text 4:

Brand Line:

Vendor Line:

Motor Weight:

Motor Weight UOM:

Shipping Weight:

Shipping Weight UOM:

Armature Field

Winding:

Core Length:

Core Length UOM:

Winding Code:

Winding Specification:

Nameplate Only

Instructions:

Nameplate & Label

Instructions:

Label Only

Instructions:

Specification & Rating Report



Rating Number: 1

Horsepower: **1/4,1/6,1/8**

Volts: **277**

Hertz: **60**

Field Current:

Revolutions Per **1075**

Minute:

Service Factor: **1.0**

Service Factor Amps:

NEMA Code:

NEMA Design:

Customer Nameplate Number:

Kilowatts:

Amps: **1.2, .75, .55**

Maximum Amps:

Armature Current:

Power Factor:

Service Factor Volts:

NEMA Nominal Efficiency:

NEMA Guaranteed Efficiency: