

PRODUCT INFORMATION PACKET



Model No: B230SE
Catalog No: B230SE
Pool Pump Motor, 2.0 HP, 1 Ph, 60 Hz, 230/115 V, 3600 RPM, Y56J Frame, DP



Regal and Century are trademarks of Regal Rexnord Corporation or one of its affiliated companies.
©2022 Regal Rexnord Corporation, All Rights Reserved. MC017097E





Nameplate Specifications

Output HP	2.0 Hp	Output KW	1.5 kW
Frequency	60 Hz	Voltage	230/115 V
Current	9.2/18.4 A	Speed	3450 rpm
Service Factor	1	Phase	1
Duty	Continuous	Insulation Class	B
Frame	Y56J	Enclosure	Drip Proof
Thermal Protection	Thermally Protected	Ambient Temperature	50 °C
UL	Recognized	CSA	Y
Number of Speeds	1		

Technical Specifications

Electrical Type	Permanent Split Capacitor, Single Or Dual Voltage	Poles	2
Rotation	Counterclockwise Pump End	Mounting	C Face
Motor Orientation	Horizontal	Drive End Bearing	Ball
Opp Drive End Bearing	Ball	Frame Material	Rolled Steel
Shaft Type	7/16 THREADS	Overall Length	14.31 in
Frame Length	8.50 in	Shaft Diameter	0.625 in
Shaft Extension	2.57 in		
Outline Drawing	B230SE	Connection Drawing	02282603-001

This is an uncontrolled document once printed or downloaded and is subject to change without notice. Date Created:11/28/2022

CEC NON-COMPLIANT STICKER ON BACK SIDE OF MOTOR

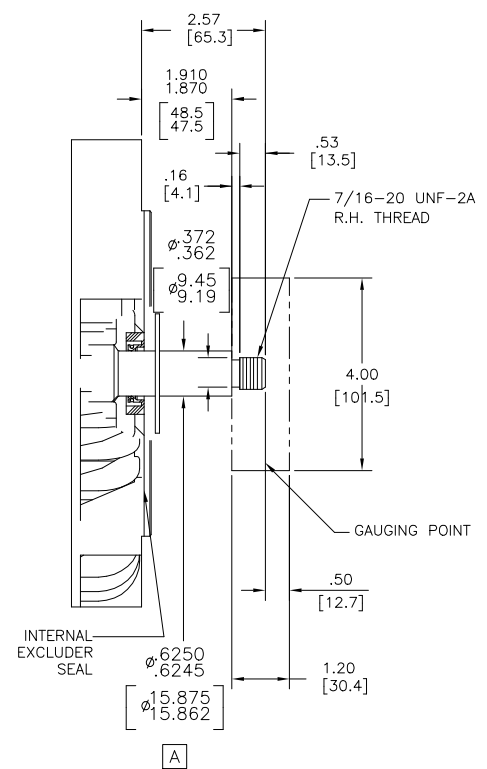
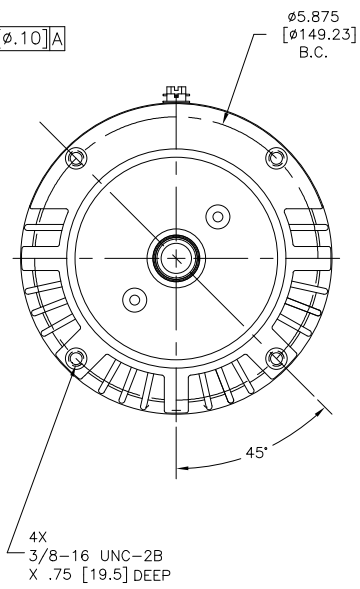
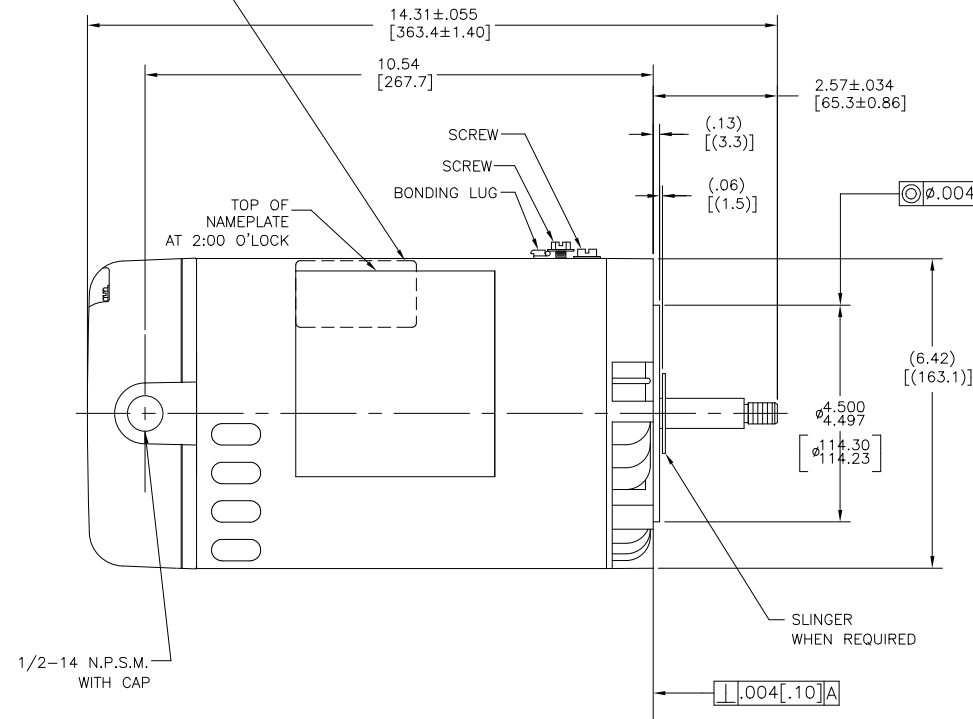

NAMEPLATE DATA

EXTERNAL CONNECTION DIAGRAM

NOTES

MODEL: 184983
 CUST PN: B230SE
 HP: 2.0 SF: 1.0
 ROT: CCWPE
 RPM: 3450
 TYPE: CX CODE: E
 FORM: FRAME: Y 56 J
 VOLTS: 230/115
 AMPS: 9.2/18.4
 MAX AMPS:
 SF AMPS: -
 PH: 1 HZ: 60
 INS: B AMB: 50°C
 DUTY: CONT
 ENCLOSURE: DP
 THERMALLY PROTECTED

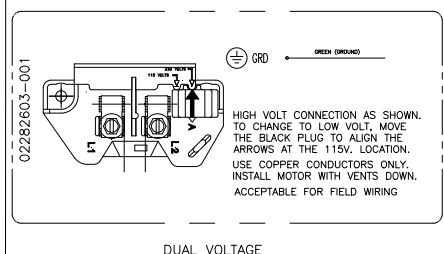

1. SHAFT RUNOUT NOT TO EXCEED .002 [0.05]
2. FOR THREADED SHAFT EXT. MATING PARTS SHOULD BE RELIEVED ONE THREAD TO CLEAR FILLET.
3. FOR THREADED SHAFT EXT. ECCENTRICITY OF THREADED PORTION OF SHAFT IS HELD WITHIN .004 [0.10] TOTAL GAGE READING WITH THE INDICATOR ON O.D. OF GROUND RING GAGE AS SHOWN. THE GAGE BEING STATIONARY WITH RESPECT TO THE ROTOR.
4. END PLAY NOT TO EXCEED .010 [0.25] MEASURED WITH NO THRUST.
5. CTQ REQUIREMENT SEE EP000105-008.
6. RoHS & REACH ETC REQUIREMENT SEE EP000014

PERFORMANCE CURVE		APPROVED SAMPLE	
16345311			
UL COMPONENT		CSA	
FILE#	CCN#	FILE#	GUIDE#
E14663	XEWR2	LR4642	4211-01

DISTRIBUTION			
--------------	--	--	--

CRITICAL TO QUALITY CHARACTERISTICS (CTQs)	DRAWING REVISION G ECO	REVISION BY MINJING JIANG TRISTIA ZHAO	DATE 04-11-2022 04-11-2022	TOLERANCES UNLESS OTHERWISE SPECIFIED DEC. INCH mm ANGLE X ±0.1 [±2.5] ±0.5° .XX ±0.02 [±0.51] .XXX ±0.005 [±0.127] XXXX ±0.0005 [±0.0127] REMOVE BURRS & BREAK SHARP EDGES .003/.015 [0.076/.381] CORNER FILLETS .02 [51] MACHINED SURFACES 12/ mm 3/2 INCH/mm	DRAWN BY: PZ DATE: 09-08-2010 APPROVED BY: CZ DATE: 09-08-2010 REFERENCE
(P) PROCESS (E) ENGINEERING (A) APPLICATION (R) REGULATORY (L) LIFE	ECO DESCRIPTION CONSOLIDATED NAMEPLATE			COPYRIGHT REGAL BELTOI AMERICA, INC. ALL RIGHTS RESERVED. REGAL BELTOI AMERICA, INC. (OWNER) AND COMPANYS OWNER'S PROPRIETARY INFORMATION. ANY PERSON, CORPORATION OR OTHER ENTITY, DUPLICATED, AND/OR USED, EXCEPT AS EXPRESSLY APPROVED IN WRITING IN ADVANCE BY OWNER. THIS DOCUMENT SHALL BE RETURNED TO OWNER UPON REQUEST. IT MAY BE SUBJECT TO CERTAIN RESTRICTIONS UNDER APPLICABLE EXPORT CONTROL LAWS AND REGULATIONS.	DESCRIPTION MODEL-CFHP-56FR OUTLINE MATERIAL PROCESS/FINISH
	THIRD ANGLE PROJECTION			SIZE DWG NO C B230SE	SHEET 1

THIRD ANGLE PROJECTION	SIZE DWG NO C B230SE	SHEET 1
------------------------	-------------------------	------------

REGAL™ Regal Beloit America, Inc.	
DESCRIPTION MODEL-CFHP-56FR OUTLINE	
MATERIAL	PROCESS/FINISH
SIZE DWG NO C B230SE	SHEET 1

AO Smith

Performance Down Project: 0443262 (High Speed)

Wednesday, August 04, 2004 04:43 AM

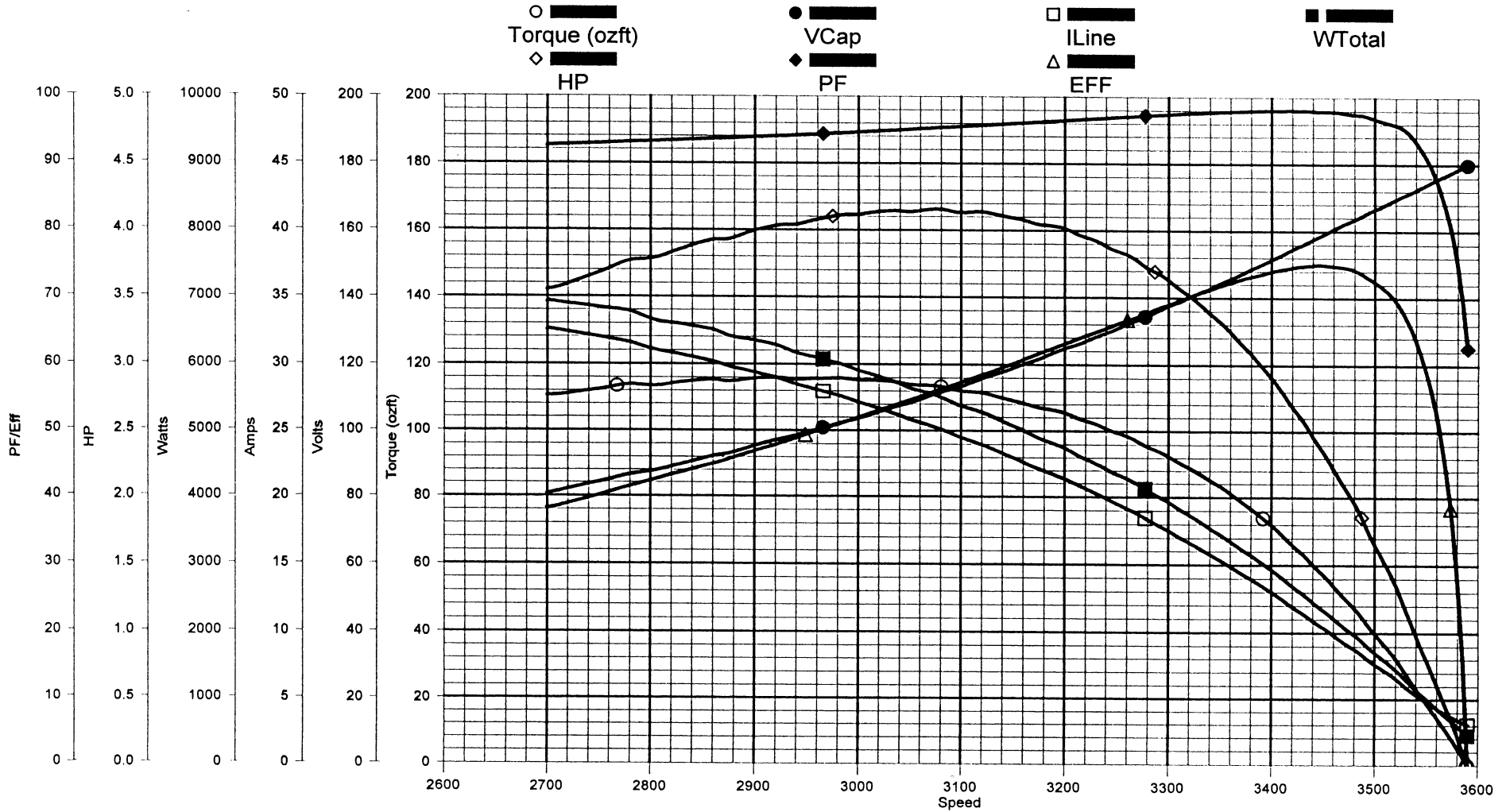

TRACKING #: 10027139
 SBU: Pump
 ENGINEER: RAY PHILLIPS
 TECHNICIAN: DAN
 BENCH: 2
 TORQUE CELL: 350 lb-in
 NP RPM: 3450
 # SPEEDS: 1
 MOTOR #: 1
 TYPE: CX

CUSTOMER: A. O. SMITH
 MODEL: 0443262A
 FRAME: 56C
 PHASES: 1
 HP: 1.50
 VOLTS: 230.0
 HERTZ: 60
 START CAP: 0.00
 RUN CAP: 25.00
 COMMENT3:

DESCRIPTION: OFFSET
 BDT: 115.83
 MT: 115.94
 SF: 46.80
 LRT: 0.00
 LRA: 0.00
 PUT: 0.00
 COMMENT1:
 COMMENT2:
 COMMENT4:

Breakdown TQ: 115.8 oz-ft
 Locked Rotor TQ: 12.4 oz-ft
 Locked Rotor Amps: 47.0 A
 Pull-up TQ: 10.0 oz-ft

AO Smith

Performance Up Project: 0443262 (High Speed)

Wednesday, August 04, 2004 05:06 AM

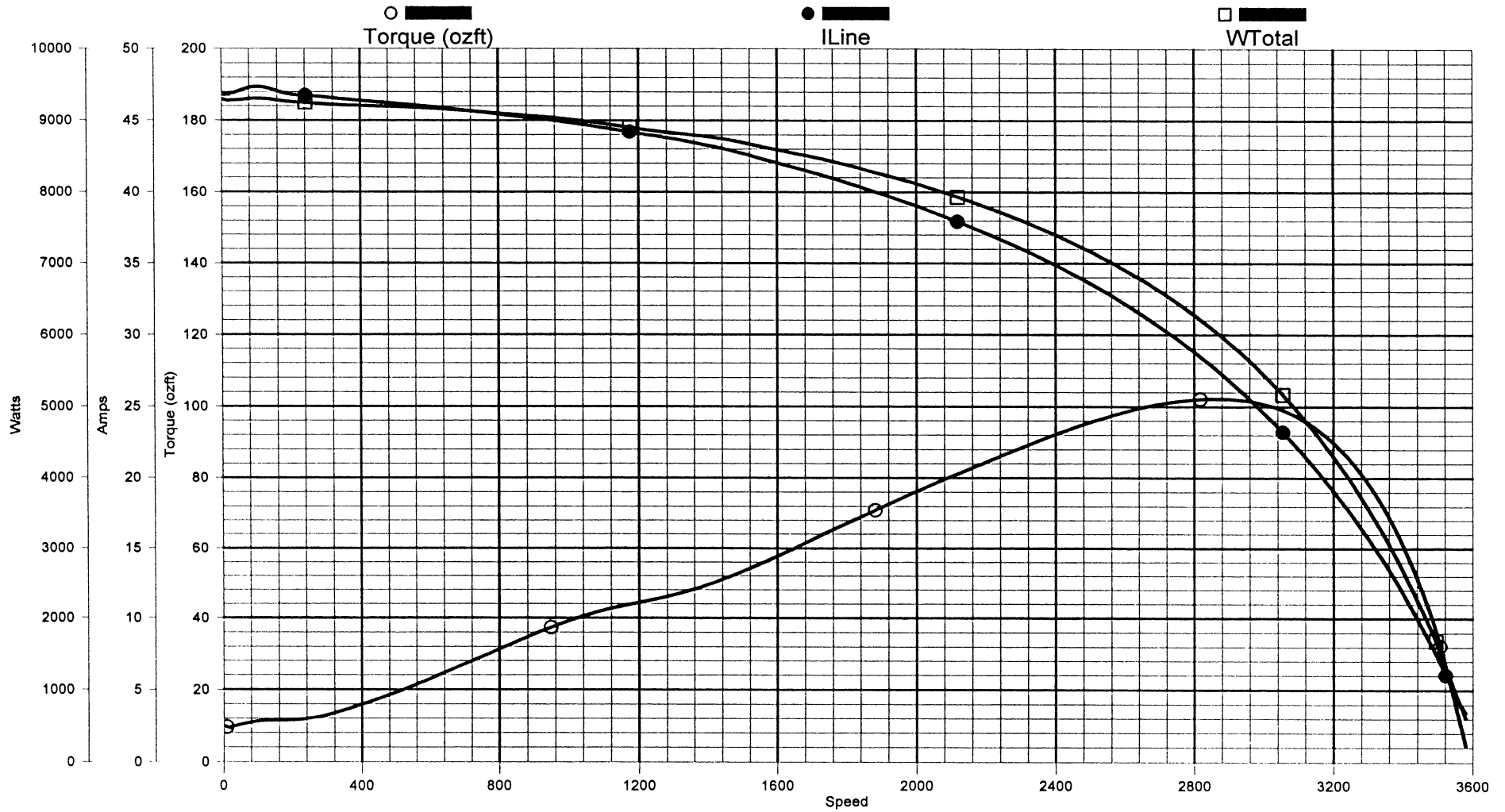

TRACKING #: 10027139
 SBU: Pump
 ENGINEER: RAY PHILLIPS
 TECHNICIAN: DAN
 BENCH: 2
 TORQUE CELL: 350 lb-in
 NP RPM: 3450
 # SPEEDS: 1
 MOTOR #: 1
 TYPE: CX

CUSTOMER: A. O. SMITH
 MODEL: 0443262A
 FRAME: 56C
 PHASES: 1
 HP: 1.50
 VOLTS: 230.0
 HERTZ: 60
 START CAP: 0.00
 RUN CAP: 25.00
 COMMENT3:

DESCRIPTION: 0-SYNC
 BDT: 102.19
 MT: 102.19
 SF: 46.80
 LRT: 9.90
 LRA: 46.82
 PUT: 9.24
 COMMENT1:
 COMMENT2:
 COMMENT4: