

# PRODUCT INFORMATION PACKET



Model No: B513ES  
Catalog No: B513ES

General Purpose Motor, 1/2 HP, 1 Ph, 60 Hz, 115/230 V, 3600 RPM, 56 Frame, ODP



Regal and Century are trademarks of Regal Rexnord Corporation or one of its affiliated companies.  
©2022 Regal Rexnord Corporation, All Rights Reserved. MC017097E





**Nameplate Specifications**

Output HP	1/2 Hp	Output KW	0.37 kW
Frequency	60 Hz	Voltage	115/230 V
Current	4.4/2.2 A	Speed	3450 rpm
Service Factor	1.25	Phase	1
Duty	Continuous	Insulation Class	B
Frame	56	Enclosure	Open Drip Proof
Thermal Protection	Automatic	Ambient Temperature	40 °C
UL	Recognized	CSA	Y
CE	Y	Number of Speeds	1

**Technical Specifications**

Electrical Type	Capacitor Start Capacitor Run	Starting Method	Across The Line
Poles	2	Rotation	Counterclockwise/Clockwise
Mounting	Rigid Base	Drive End Bearing	Ball
Opp Drive End Bearing	Ball	Frame Material	Rolled Steel
Shaft Type	Keyed	Overall Length	10.94 in
Frame Length	7.13 in	Shaft Diameter	0.625 in
Shaft Extension	1.88 in		
Connection Drawing	9513517	Outline Drawing	SS404131

This is an uncontrolled document once printed or downloaded and is subject to change without notice. Date Created:11/28/2022

SS404131

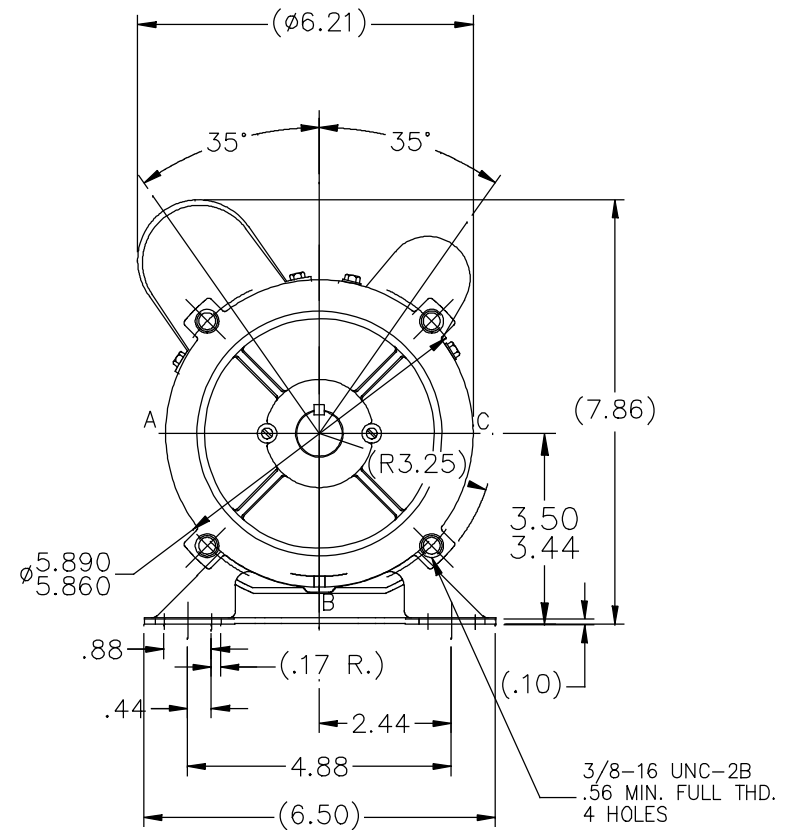
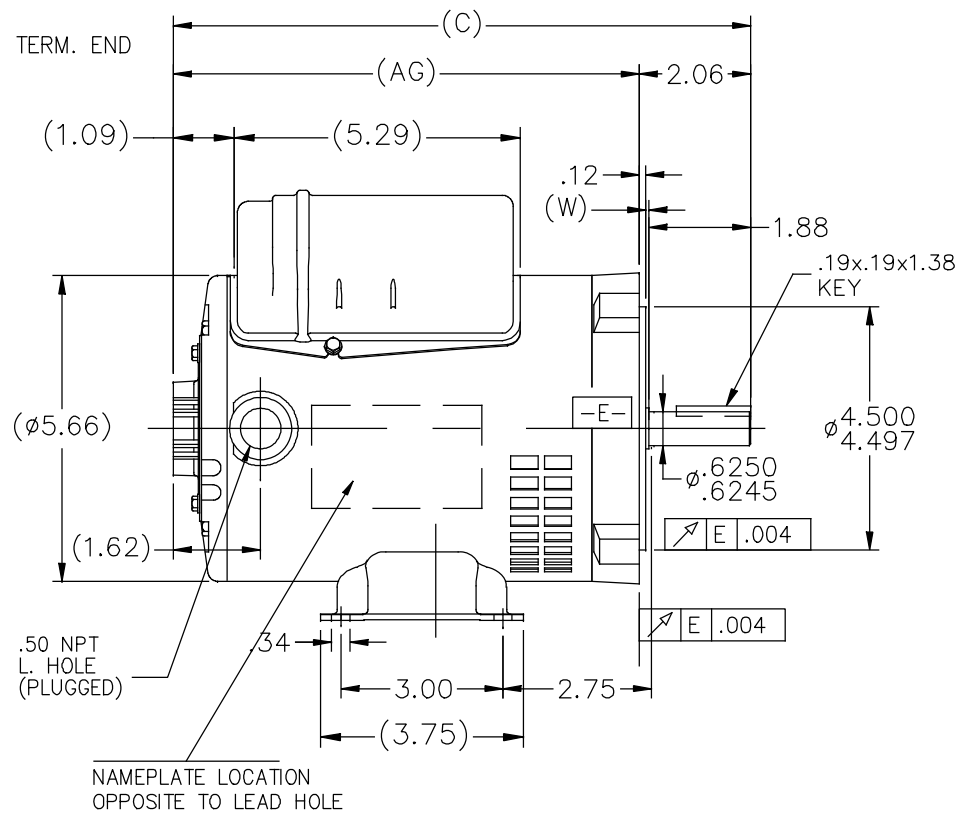

DASH	C	AG		DASH	C	AG	
625	10.19	8.13		725	11.19	9.13	
650	10.44	8.38		750	11.44	9.38	
675	10.69	8.63		775	11.69	9.63	
700	10.94	8.88		800	11.94	9.88	

'W' = CLEARANCE ALLOWED FOR ALL VARIANCES IN MANUFACTURING & ASSEMBLY

			TOLERANCES UNLESS SPECIFIED		 <b>Regal Beloit America, Inc.</b>	DRAWN PVR 12/23/14	
			DEC.	INCHES		CHK VS 12/23/14	APPD
03	NAMEPLATE LOCATION CHANGED	UD 10/24/19	.XX	±.03	TITLE OUTLINE	SCALE	3=8
02	UPDATED NAME PLATE LOC.	PVR 05-26-17	.XXX	±.005		REF	
01	NAME PLATE LOC. UPD PER ECO-0092253	KK 01/21/15	.XXXX	±.0005	MAT'L.	FMF	
NO.	REVISION	BY & DATE	CHK	ANG ±7'30"	FINISH	PREV	
THIS DRAWING IN DESIGN AND DETAIL IS OUR PROPERTY AND MUST NOT BE USED EXCEPT IN CONNECTION WITH OUR WORK ALL RIGHTS OF DESIGN AND INVENTION ARE RESERVED THIS IS AN ELECTRONICALLY GENERATED DOCUMENT - DO NOT SCALE THIS PRINT			RFP		CAD FILE SS404131	SIZE	DRAWING NO. PAGE 1 OF 1
			DIST	WP		A	SS404131 D

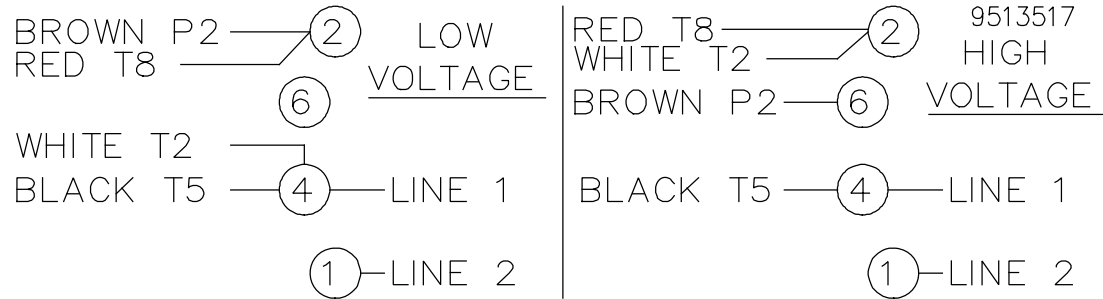

ROTATION CCW-OPE TO REVERSE EITHER VOLTAGE  
INTERCHANGE BLACK(T5) WITH RED(T8) LEADS

				TOLERANCES UNLESS SPECIFIED			DRAWN TOM 06-21-1988						
				DEC.	INCHES		CHK	GK 06-21-1988					
				.X	±.1		APPD	FG 06-21-1988					
3	ADDED T MARKINGS	DS 07/19/2018	VC	.XX	±.02	TITLE CONNECTION DIAGRAM	SCALE	1=1					
2	REDRAWN IN AUTOCAD	TAT 10-22-2004	ML	.XXX	±.005		REF						
1	NEW DRAWING	TOM 06-24-1988		.XXXX	±.0005		MAT'L.	FMF					
NO.	REVISION	BY & DATE	CHK	ANG	±7'30"	FINISH	PREV						
THIS DRAWING IN DESIGN AND DETAIL IS OUR PROPERTY AND MUST NOT BE USED EXCEPT IN CONNECTION WITH OUR WORK ALL RIGHTS OF DESIGN AND INVENTION ARE RESERVED THIS IS AN ELECTRONICALLY GENERATED DOCUMENT - DO NOT SCALE THIS PRINT						RFP	CAD FILE	9513517	SIZE	DRAWING NO.	PAGE	OF	REV.
						DIST			A	9513517			3