

# PRODUCT INFORMATION PACKET



Model No: B652ES  
Catalog No: B652ES

General Purpose Motor, 3/4 HP, 1 Ph, 60 Hz, 115/230 V, 3600 RPM, 56 Frame, ODP



Regal and Century are trademarks of Regal Rexnord Corporation or one of its affiliated companies.  
©2022 Regal Rexnord Corporation. All Rights Reserved. MC017097E





**Nameplate Specifications**

Output HP	<b>3/4 Hp</b>	Output KW	<b>0.56 kW</b>
Frequency	<b>60 Hz</b>	Voltage	<b>115/230 V</b>
Current	<b>7.2/3.6 A</b>	Speed	<b>3450 rpm</b>
Service Factor	<b>1.25</b>	Phase	<b>1</b>
Efficiency	<b>76.2 %</b>	Duty	<b>Continuous</b>
Insulation Class	<b>B</b>	Frame	<b>56</b>
Enclosure	<b>Open Drip Proof</b>	Thermal Protection	<b>Automatic</b>
Ambient Temperature	<b>40 °C</b>	UL	<b>Recognized</b>
CSA	<b>Y</b>	CE	<b>Y</b>
Number of Speeds	<b>1</b>		

**Technical Specifications**

Electrical Type	<b>Capacitor Start Capacitor Run</b>	Starting Method	<b>Across The Line</b>
Poles	<b>2</b>	Rotation	<b>Counterclockwise/Clockwise</b>
Mounting	<b>Rigid Base</b>	Drive End Bearing	<b>Ball</b>
Opp Drive End Bearing	<b>Ball</b>	Frame Material	<b>Rolled Steel</b>
Shaft Type	<b>Keyed</b>	Overall Length	<b>11.44 in</b>
Frame Length	<b>7.63 in</b>	Shaft Diameter	<b>0.625 in</b>
Shaft Extension	<b>2 in</b>		
Connection Drawing	<b>9513517</b>	Outline Drawing	<b>SS404131</b>

This is an uncontrolled document once printed or downloaded and is subject to change without notice. Date Created:11/28/2022

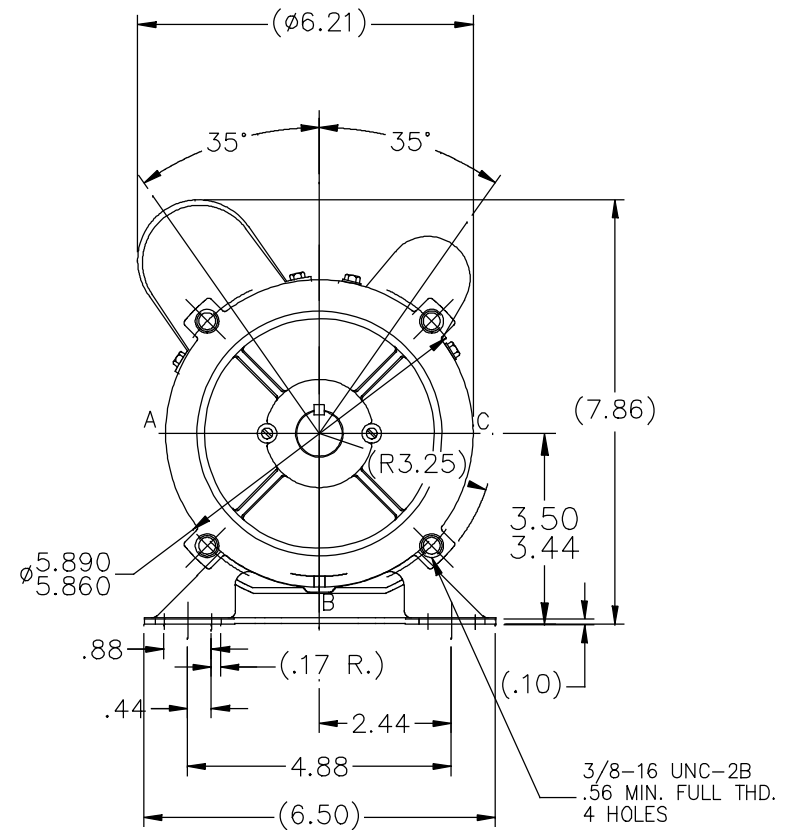
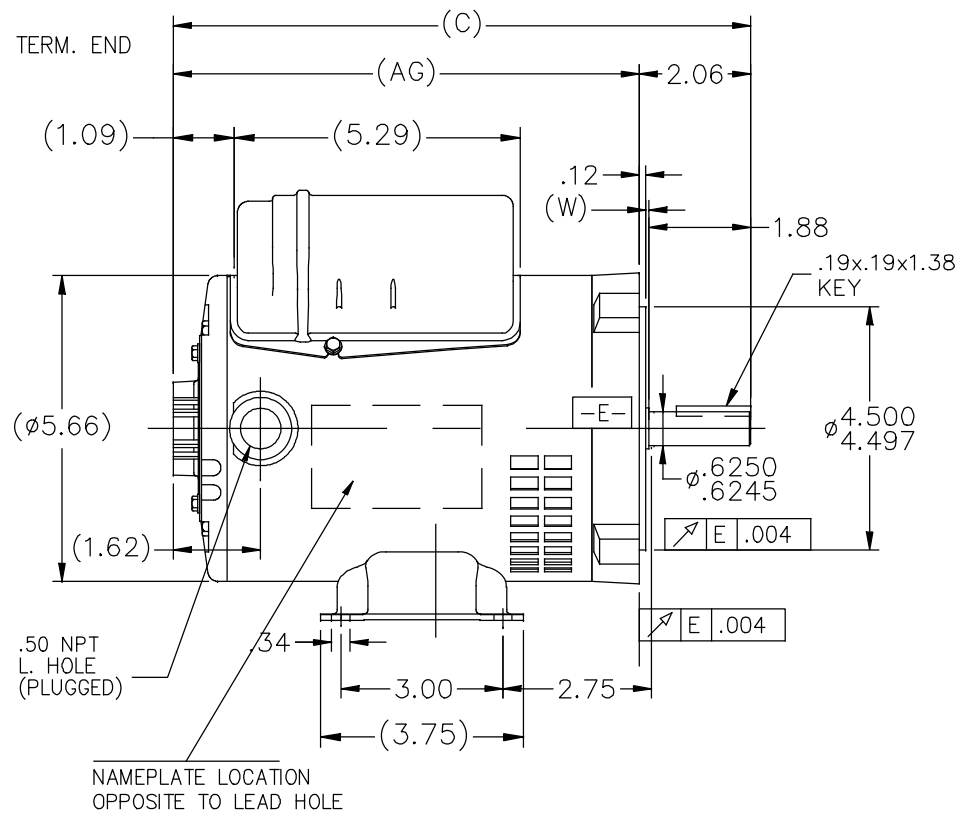

DASH	C	AG		DASH	C	AG	
625	10.19	8.13		725	11.19	9.13	
650	10.44	8.38		750	11.44	9.38	
675	10.69	8.63		775	11.69	9.63	
700	10.94	8.88		800	11.94	9.88	

'W' = CLEARANCE ALLOWED FOR ALL VARIANCES IN MANUFACTURING & ASSEMBLY

				TOLERANCES UNLESS SPECIFIED		 <b>Regal Beloit America, Inc.</b>	DRAWN PVR 12/23/14		
				DEC.	INCHES		CHK VS 12/23/14	APPD	
				.X	±.1	TITLE OUTLINE	SCALE	3=8	
03	NAMEPLATE LOCATION CHANGED		UD 10/24/19	.XX	±.03		REF		
02	UPDATED NAME PLATE LOC.		PVR 05-26-17	.XXX	±.005		FMF		
01	NAME PLATE LOC. UPD PER ECO-0092253		KK 01/21/15	.XXXX	±.0005	MAT'L.			
NO.	REVISION		BY & DATE	CHK	ANG	FINISH	PREV		
THIS DRAWING IN DESIGN AND DETAIL IS OUR PROPERTY AND MUST NOT BE USED EXCEPT IN CONNECTION WITH OUR WORK ALL RIGHTS OF DESIGN AND INVENTION ARE RESERVED THIS IS AN ELECTRONICALLY GENERATED DOCUMENT - DO NOT SCALE THIS PRINT				RFP		CAD FILE SS404131	SIZE	DRAWING NO. PAGE 1 OF 1	
				DIST	WP		A	SS404131	
								REV. D	

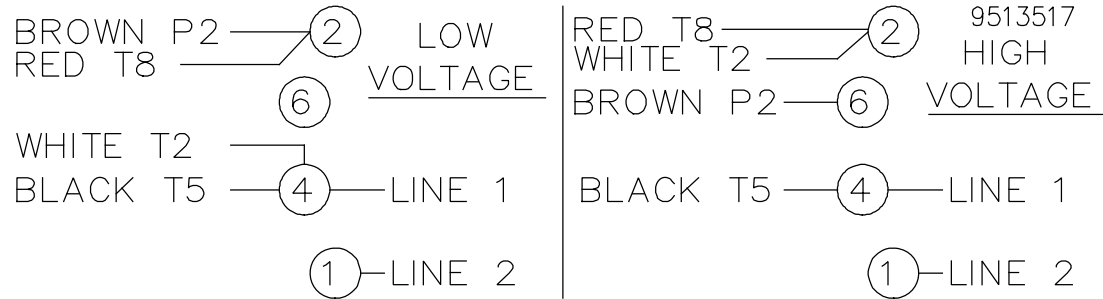

ROTATION CCW-OPE TO REVERSE EITHER VOLTAGE  
 INTERCHANGE BLACK(T5) WITH RED(T8) LEADS

				TOLERANCES UNLESS SPECIFIED			DRAWN TOM 06-21-1988						
				DEC.	INCHES		CHK	GK 06-21-1988					
				.X	±.1		APPD	FG 06-21-1988					
3	ADDED T MARKINGS	DS 07/19/2018	VC	.XX	±.02	TITLE CONNECTION DIAGRAM	SCALE	1=1					
2	REDRAWN IN AUTOCAD	TAT 10-22-2004	ML	.XXX	±.005		REF						
1	NEW DRAWING	TOM 06-24-1988		.XXXX	±.0005		MAT'L.	FMF					
NO.	REVISION	BY & DATE	CHK	ANG	±7'30"	FINISH	PREV						
THIS DRAWING IN DESIGN AND DETAIL IS OUR PROPERTY AND MUST NOT BE USED EXCEPT IN CONNECTION WITH OUR WORK ALL RIGHTS OF DESIGN AND INVENTION ARE RESERVED THIS IS AN ELECTRONICALLY GENERATED DOCUMENT - DO NOT SCALE THIS PRINT						RFP	CAD FILE	9513517	SIZE	DRAWING NO.	PAGE	OF	REV.
						DIST			A	9513517			3