

PRODUCT INFORMATION PACKET



Model No: BL6407

Catalog No: BL6407

OEM Replacement Motor, 1/6 HP, 1 Ph, 60 Hz, 115 V, 1000 RPM, 1 Speed, 42 Frame, OAO



Regal and Century are trademarks of Regal Rexnord Corporation or one of its affiliated companies.
©2025 Regal Rexnord Corporation, All Rights Reserved. MC017097E





Nameplate Specifications

Phase	1	Output HP	1/6 Hp
Output KW	0.13 kW	Voltage	115 V
Speed	1000 rpm	Service Factor	1.0
Frame	42Y	Enclosure	Open Air Over
Thermal Protection	Automatic	Ambient Temperature	40 °C
Frequency	60 Hz	Current	7.8 A
Duty	Air Over	Insulation Class	B
UL	Recognized	CSA	Y
CE	N	Number of Speeds	1

Technical Specifications

Electrical Type	Shaded Pole	Starting Method	Across The Line
Poles	6	Rotation	Counterclockwise Lead End
Mounting	Round Belly Band	Motor Orientation	Any
Drive End Bearing	Sleeve	Opp Drive End Bearing	Sleeve
Frame Material	N/A	Shaft Type	Flat
Overall Length	7.41 in	Shaft Diameter	0.500 in
Shaft Extension	3 in		
Connection Drawing	261B865F01	Outline Drawing	11722-002-S01

This is an uncontrolled document once printed or downloaded and is subject to change without notice. Date Created:06/11/2025

REV	ECO	REV BY	DATE	APPD	DATE
EA	ECR-0242877	ANJANI	05-29-2025	DARREL CLAYTON	05-29-2025

GENERAL INFORMATION:

SHAFT RUNOUT: .001 [.03] T.I.R. PER INCH LENGTH OF EXTENSION
 END PLAY: .010[.25] TO .063[1.60]
 BEARINGS: SLEEVE
 MOUNTING POSITION: ALL ANGLE

ELECTRICAL DATA:

OVERLOAD PROTECTOR: AUTOMATIC RESET (T.I. 7AM 304)
 LEADS: NO. 18 GA., .06 [1.5] THK. 90°C INSUL., 2 CONDUCTOR BLACK RIPCORD
 GROUND LEAD: NO. 18 GA., .03 [.8] THK. (GREEN) INSUL.

NOTE:
 DISTRIBUTION: CUST. P/N: BL6407
 GRAINGER: CUST. P/N: 4KA22

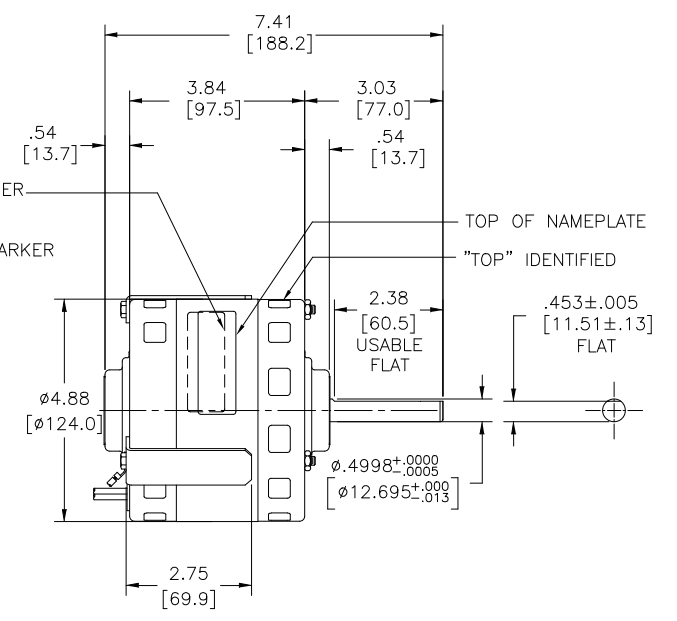
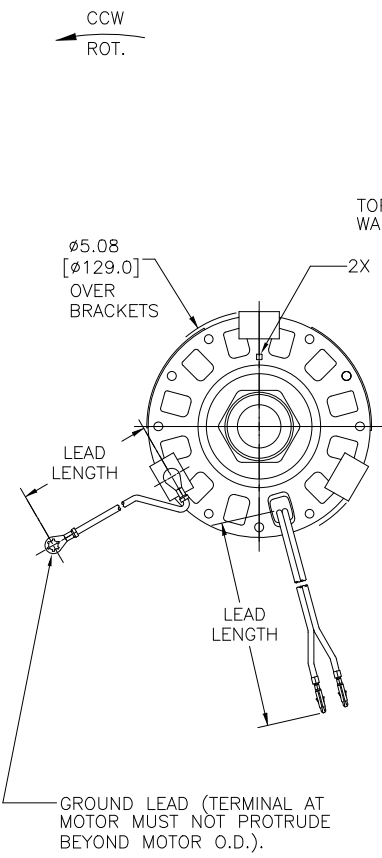

NAMEPLATE DATA:	EXTERNAL CONNECTION DIAGRAM
MODEL NO.: B42A81A01 CUST. P/N: [] HP: 1/6 ROT.: CCWLE RPM: 1000 TYPE: FE FRAME: 42Y VOLTS: 115 PH: 1 AMPS: 7.8 HZ: 60 INS.: B AMB.: 40°C DUTY: AIR OVER CAP.: - UL LOGO CSA LOGO THERMALLY PROTECTED TYPE C	

SEE NOTE

NOTE:
 1. MOTOR SHIPPED WITH LEADS AND PIN TERMINALS INSIDE PROTECTIVE TUBE.
 ⊕ MAX. DIA. OVER INSUL. GRIP OF PIN TERMINAL IS .217[5.51]

GREEN (GROUND)	6.0/7.0 [152/178]	#10 EYELET
2 COND RIPCORD	26.0/28.0 [660/711]	AMP PIN #350538-1
COLOR	LENGTH	TERMINAL OR STRIP LENGTH

MAIN FRAME - OLE	OPEN
END FRAME - OLE	OPEN
MAIN FRAME - LE	OPEN
END FRAME - LE	OPEN

CUSTOMER	DISTRIBUTION SERVICE
----------	----------------------

PERFORMANCE CURVE NO.	TORQUE @ 1075 RPM (25°C)	APPROVED SAMPLE	UL COMPONENT	CSA
C31975	22.2 OZ. FT.	PSD7591C	E46412 PRGY2	LR43341 260-Ø-0

LEAD DATA

DR BY:	CORDON	05-17-2004
APPD:	CORDON	05-20-2004
THIRD ANGLE PROJECTION		
EDS DATE	11-11-2011	
FORMAT REV	H	

Regal Rexnord Regal Beloit America, Inc.

DESCRIPTION: **OUTLINE**

SIZE	C	DWG NO	11722-002
SCALE	NONE	SHEET	1

GEOMETRIC CHARACTERISTICS & SYMBOLS ▭ FLATNESS - STRAIGHTNESS < ANGULARITY ⊥ PERPENDICULARITY (SQUARENESS) // PARALLELISM ○ ROUNDNESS (CIRCULARITY) ⊙ CYLINDRICITY ⌒ PROFILE OF ANY SURFACE ⌒ PROFILE OF ANY LINE ? RUNOUT ⊕ TRUE POSITION ⊙ CONCENTRICITY = SYMMETRY	REGAL-BELOIT CORPORATION (RBC) PROVIDES TECHNICAL ASSISTANCE TO OUR CUSTOMERS IN SEVERAL AREAS. SINCE RBC DOES NOT RECEIVE ALL DATA CONCERNING THE USE AND APPLICATION OF THE MOTOR, THE SUITABILITY OF THE MOTOR FOR THE APPLICATION MUST BE DETERMINED BY THE CUSTOMER. DIMENSIONS WITHOUT TOLERANCES ARE FOR REFERENCE ONLY.
--	--

REV	ECO	REV BY	DATE	APPD	DATE
T	ECO-0018824	J.HESS	04-15-2011	J.HESS	04-15-2011

FOR SINGLE SPEED ONLY
COLOR OF LEADS TO BE OPTIONAL

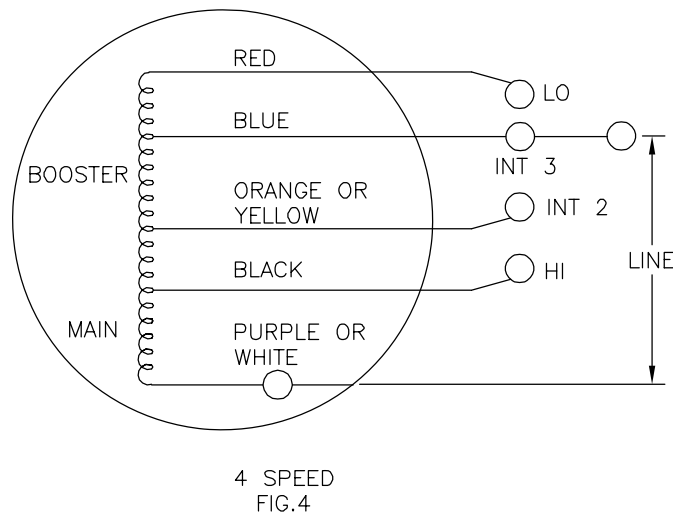
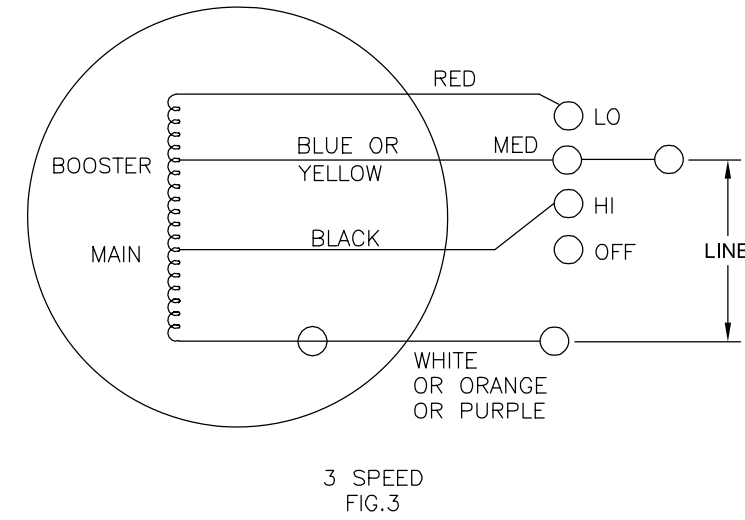
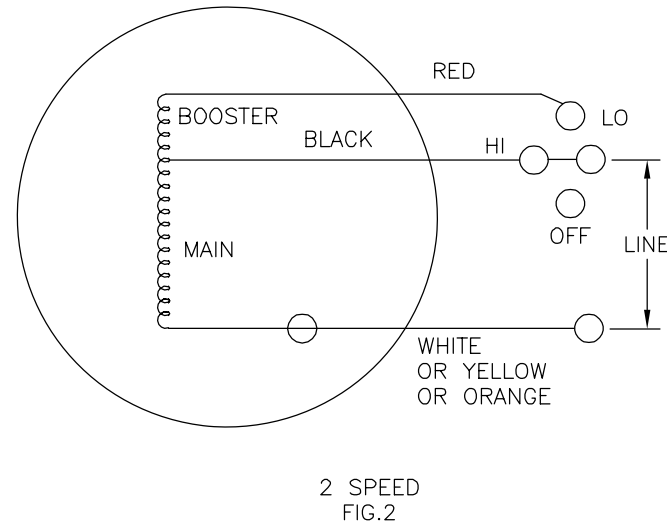
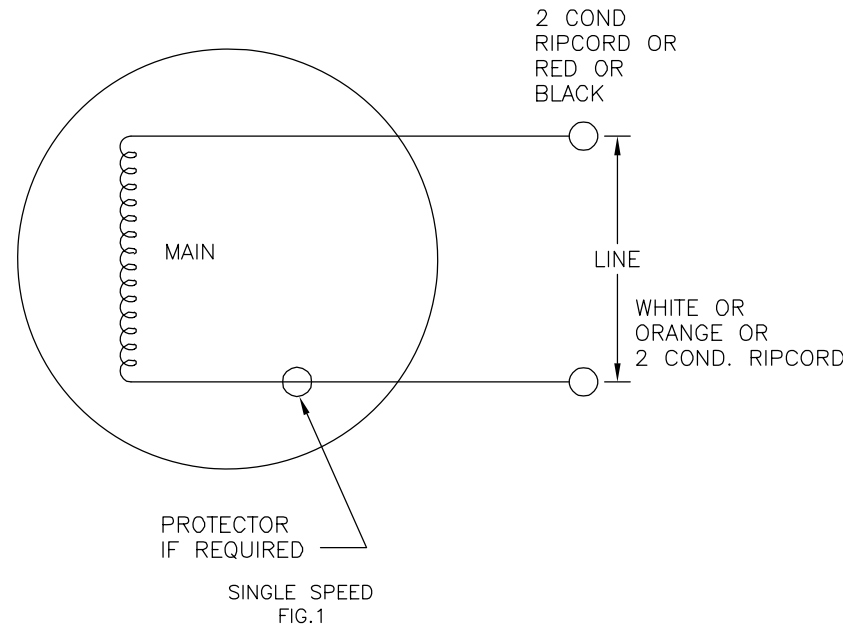

QUALITY CONTROL NOTE:
TO CHECK THE WINDINGS FOR OPENS VERIFY THE CONTINUITY AS OUTLINED BELOW.
FIG.1 BETWEEN WHITE AND BLACK OR WHITE & RED LEADS
FIG.2, 3 & 4, BETWEEN THE WHITE & RED LEADS.

GEOMETRIC CHARACTERISTICS & SYMBOLS

- ▭ FLATNESS
- STRAIGHTNESS
- ∠ ANGULARITY
- ⊥ PERPENDICULARITY (SQUARENESS)
- // PARALLELISM
- ROUNDNESS (CIRCULARITY)
- ⊘ CYLINDRICITY
- △ PROFILE OF ANY SURFACE
- ∩ PROFILE OF ANY LINE
- ↗ RUNOUT
- ⊕ TRUE POSITION
- ◎ CONCENTRICITY
- ≡ SYMMETRY

UNLESS OTHERWISE SPECIFIED
DIM. TOLERANCES ARE AS FOLLOWS:

INCH	±.1	±.02	±.005	±.0005
mm	±0.5	±0.13	±0.013	

ANG. ±.50 DEG
REMOVE BURRS & BREAK SHARP EDGES:
INCH .003-.015 mm 0.1-0.4
CORNER FILLETS TO:
INCH .020 mm 0.5
MACHINE SURFACES:
INCH 125 mm 3.2
METRIC DIMS. SHOWN IN [BRACKETS]

DR BY:	KLINE	10-24-1966
APPD:	RDS	10-27-1966
THIRD ANGLE PROJECTION		EDS DATE 02-22-2008 FORMAT REV F
CONFIDENTIAL: THIS DRAWING AND ITS INFORMATION ARE THE EXCLUSIVE AND CONFIDENTIAL PROPERTY OF A.O. SMITH CORP. AND ARE NOT TO BE DISCLOSED, DUPLICATED, DISTRIBUTED OR OTHERWISE USED WITHOUT THE WRITTEN CONSENT OF A.O. SMITH CORP. -ALL RIGHTS RESERVED. ASME Y14.5M 1994		

ACSmith Innovation has a name.		ELECTRICAL PRODUCTS COMPANY A DIVISION OF A. O. SMITH CORPORATION	
DESCRIPTION CONN DIAGRAM-EXTERNAL			
SIZE C	DWG NO 261B865F01	SHEET 1	
SCALE NONE			

4

3

2

1

REVISION:	ECO	REVISADO POR:	FECHA:	APROBADO POR:	FECHA:
T	ECO-0018824	J.HESS	04-15-2011	J.HESS	04-15-2011

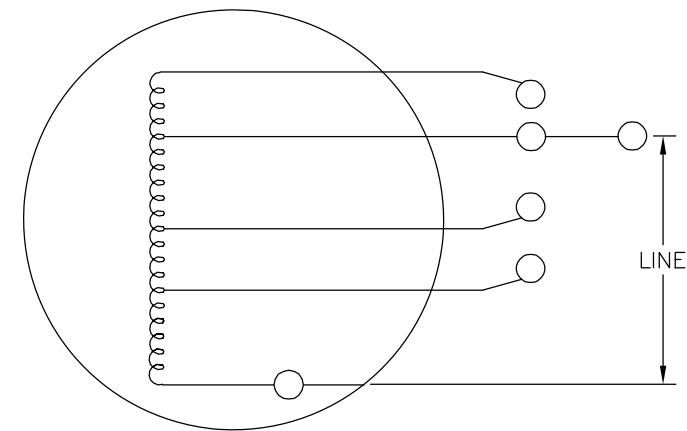
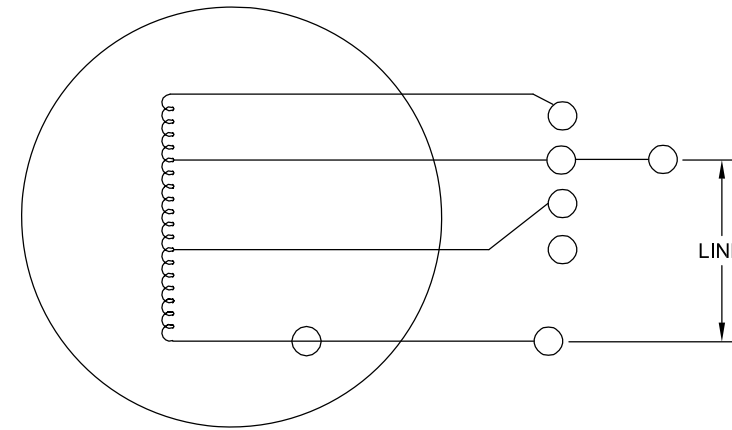
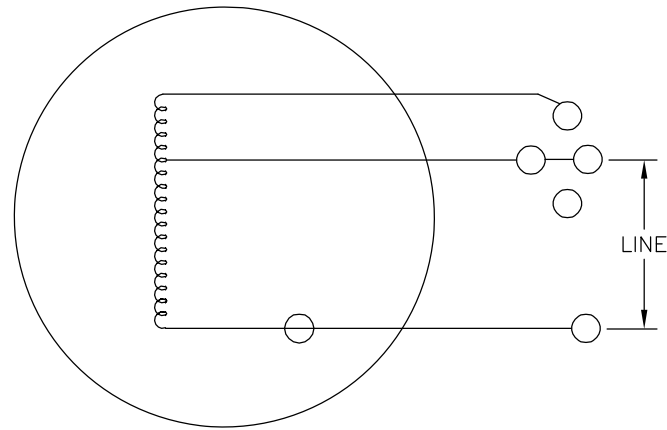
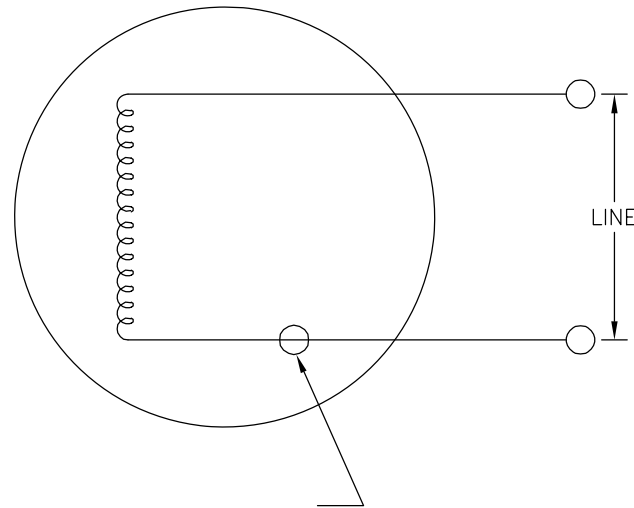

CARACTERISTICAS DE GEOMETRIA Y SIMBOLOS

- ▭ PLANICIDAD
- RECTITUD
- ∠ ANGULARIDAD
- ⊥ PERPENDICULARIDAD (A ESCUADRA)
- // PARALELISMO
- REDONDEZ (CIRCULARIDAD)
- ∅ CILINDRICIDAD
- △ PERFIL DE CUALQUIER SUPERFICIE
- ∩ PERFIL DE CUALQUIER LINEA
- ↑ VARIACION
- ⊕ POSICION REAL
- ◎ CONCENTRICIDAD
- = SIMETRIA

A MENOS QUE SE ESPECIFIQUE DE OTRA MANERA, LAS TOLERANCIAS DE LAS DIMS; SON LAS SIGUIENTES:

PULG	±.1	±.02	±.005	±.0005
mm	±0.5	±0.13	±0.013	

ANG. ± 50 GRADOS
ELIMINAR REBABAS Y ORILLAS FILOSAS DEL BORDE.

PULG	.003-.015	mm	0.1-0.4
------	-----------	----	---------

FILETEAR ESQUINA: PULG .020 mm 0.5
MAQUINAR SUPERFICIES
PULG 125 mm .32

DIMS METRICAS MOSTRADAS [PARENTESIS]

DIBUJADO POR:	KLINE	10-24-1966
APROBADO POR:	RDS	10-27-1966
TERCER ANGULO DE PROYECCION	⊕	FECHA EDS: 02-22-2008 REV. FORMATO: F
CONFIDENCIAL: ESTE DIBUJO Y SU INFORMACION SON PROPIEDAD DE USO EXCLUSIVO Y CONFIDENCIAL DE A.O.SMITH CORP. Y NO DEBERAN SER REVELADOS, DUPLICADOS, DISTRIBUIDOS O USARSE DE OTRA MANERA SIN EL CONSENTIMIENTO ESCRITO DE A.O. SMITH CORP. -TODOS LOS DERECHOS RESERVADOS.ASME Y14.5M 1994		

ACSmith **ELECTRICAL PRODUCTS COMPANY**
Innovation has a name. A DIVISION OF A. O. SMITH CORPORATION

DESCRIPCION: **CONN DIAGRAM-EXTERNAL**

TAMAÑO: C NUMERO DE DIBUJO: 261B865F01

ESCALA:NONE HOJA: 1

4

3

2

1

4

3

2

1

版本	ECO	编制	日期	批准	日期
T	ECO-0018824	J.HESS	04-15-2011	J.HESS	04-15-2011

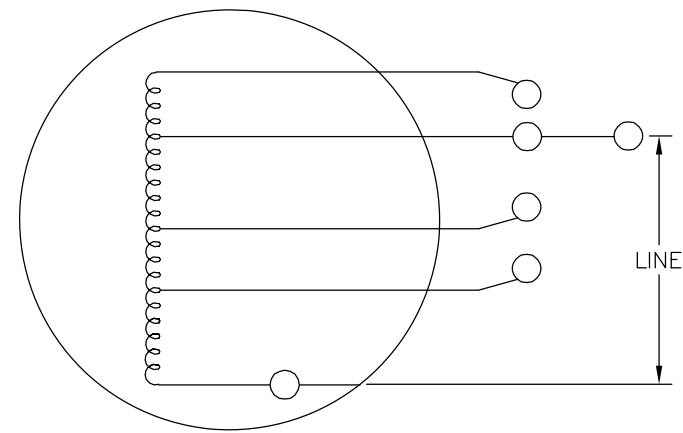
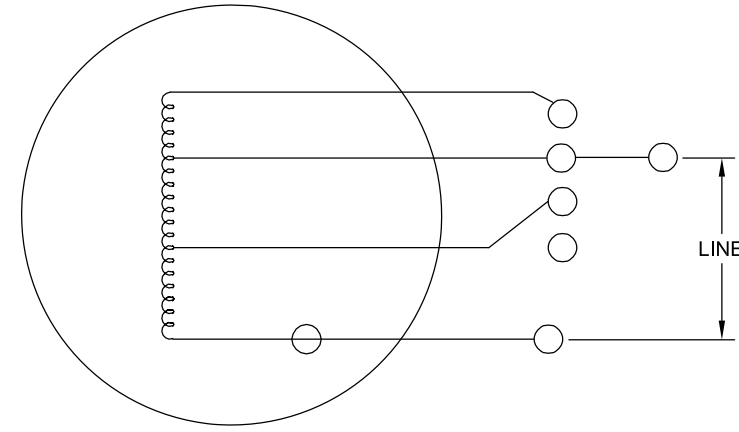
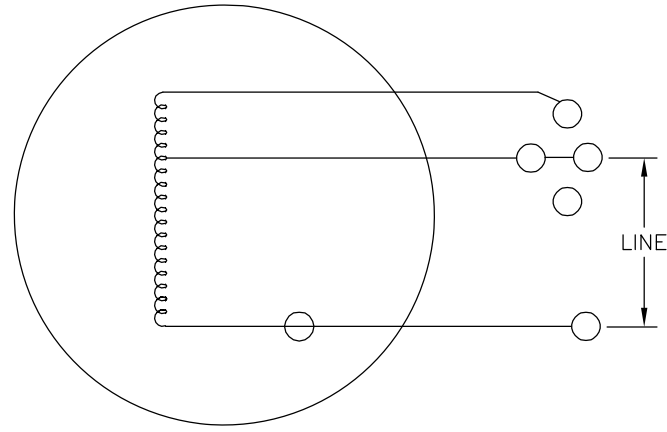
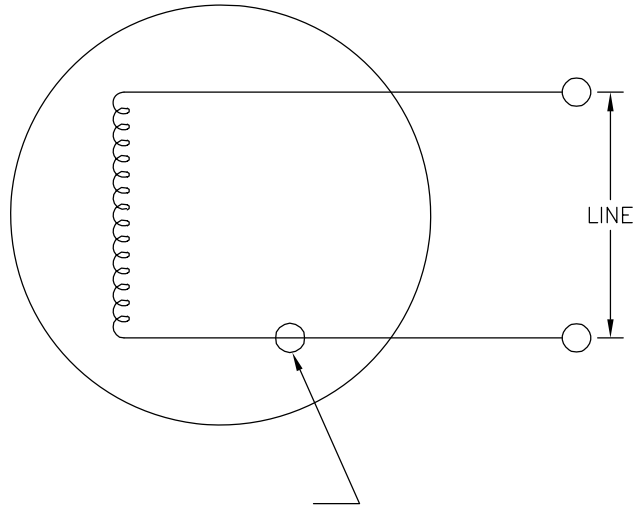

形位公差
□ 平面度
— 直线度
∠ 倾斜度
⊥ 垂直度
// 平行度
○ 圆度
⊙ 圆柱度
∩ 内圆角
△ 面轮廓度
∩ 线轮廓度
↗ 圆跳动
⊕ 位置度
⊗ 同轴度
≡ 对称度

除另有注明 尺寸公差如下:
英寸 X XX XXX XXXX
毫米 ±0.1 ±0.02 ±0.005 ±0.0005
毫米 ±0.5 ±0.13 ±0.013
角度 ±.50 度
清理毛刺和尖棱
英寸 .003-.015 毫米 0.1-0.4
内圆角
英寸 .020 毫米 0.5
表面粗糙度
英制 125 米制 3.2
米制尺寸显示在 []

绘图:	KLINE	10-24-1966
批准:	RDS	10-27-1966
第三角投影		图纸格式发布日期 02-22-2008 图纸格式版本 F
机密: 本图纸及相关信息所有权归A. O. SMITH公司所有。 未经A. O. SMITH公司书面授权, 不得泄露、复制、传播或作 其他用途。—版权所有		
ASME Y14.5M 1994		

ACSmith Innovation has a name.		ELECTRICAL PRODUCTS COMPANY A DIVISION OF A. O. SMITH CORPORATION	
名称 CONN DIAGRAM-EXTERNAL			
图幅	C	图号	261B865F01
比例	NONE	页号	1

4

3

2

1