

PRODUCT INFORMATION PACKET



Model No: C218

Catalog No: C218

Pressure Washer Motor, 3.0 HP, 1 Ph, 60 Hz, 208-230 V, 1800 RPM, Y145T Frame, DP



Regal and Century are trademarks of Regal Rexnord Corporation or one of its affiliated companies.

©2023 Regal Rexnord Corporation, All Rights Reserved. MC017097E





Nameplate Specifications

Output HP	3.0 Hp	Output KW	2.2 kW
Frequency	60 Hz	Voltage	208-230 V
Current	13.5 A	Speed	1725 rpm
Service Factor	1.15	Phase	1
Duty	Continuous	Insulation Class	B
Frame	Y145T	Enclosure	Drip Proof
Thermal Protection	Thermally Protected	Ambient Temperature	40 °C
UL	Recognized	CSA	Y
CE	N	Number of Speeds	1

Technical Specifications

Electrical Type	Capacitor Start, Capacitor Run, Single Or Dual Voltage	Starting Method	Across The Line
Poles	4	Rotation	Reversible Counterclockwise
Mounting	Rigid Base	Drive End Bearing	Ball
Opp Drive End Bearing	Ball	Frame Material	Rolled Steel
Shaft Type	Keyed	Overall Length	15.06 in
Frame Length	9.25 in	Shaft Diameter	0.875 in
Shaft Extension	2.31 in		
Connection Drawing	17050512.PCX	Outline Drawing	C218-S01

This is an uncontrolled document once printed or downloaded and is subject to change without notice. Date Created:03/15/2023

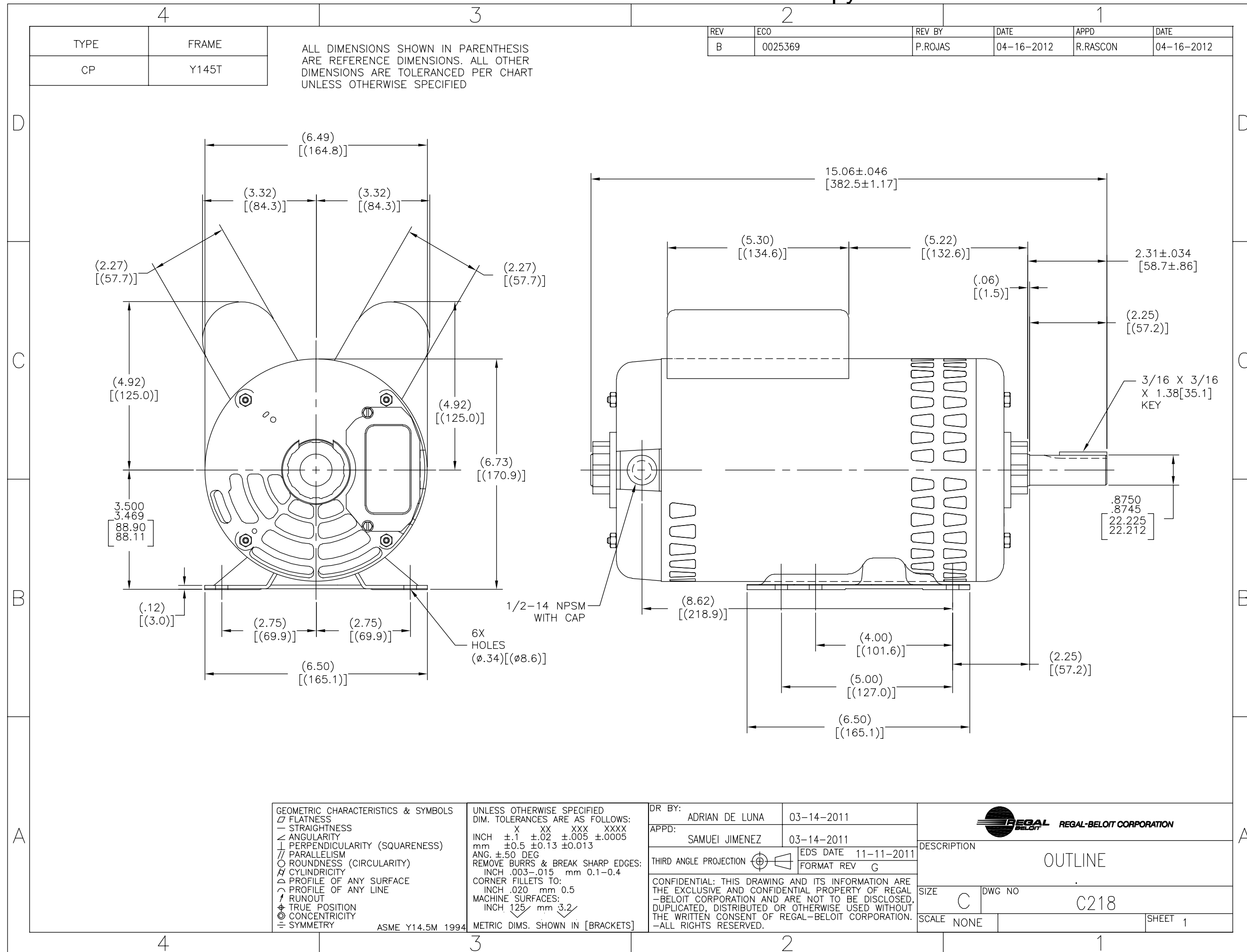

4

3

2

1

TIPO	CARCAZA
CP	Y145T

TODAS LAS DIMENSIONES MOSTRADAS EN PARENTESIS SON DIMENSIONES DE REFERENCIA. TODAS LA DEMAS DIMENSIONES TIENEN TOLERANCIAS DE ACUERDO A LA TABLA A MENOS QUE SE ESPECIFIQUE OTRA COSA

REVISION:	ECO	REVISADO POR:	FECHA:	APROBADO POR:	FECHA:
B	0025369	P.ROJAS	04-16-2012	R.RASCON	04-16-2012

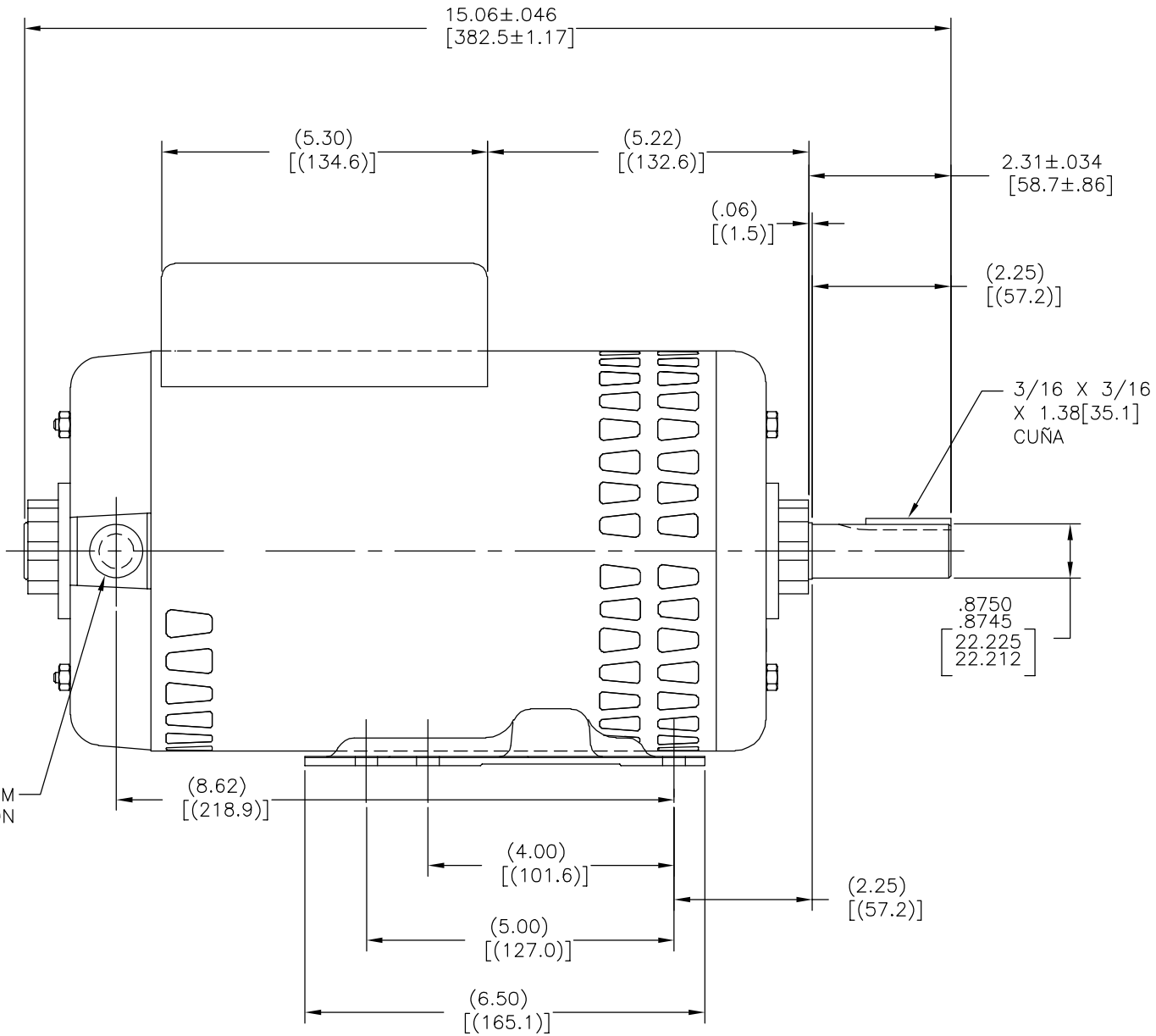
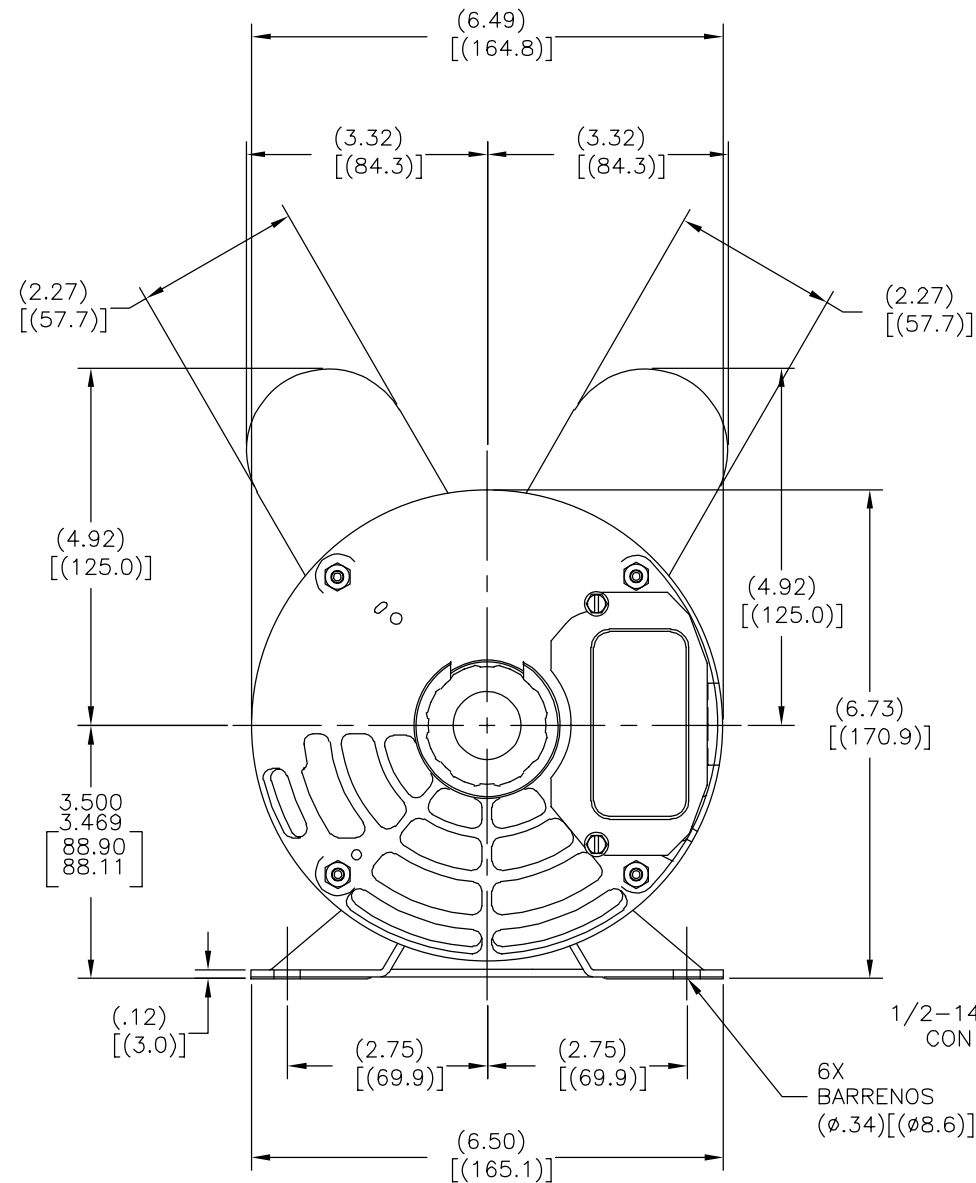

1/2-14 NPSM CON TAPON
6X BARRENOS (Ø.34) [(Ø8.6)]

CARACTERISTICAS DE GEOMETRIA Y SIMBOLOS

- PLANICIDAD
- RECTITUD
- ∠ ANGULARIDAD
- ⊥ PERPENDICULARIDAD (A ESCUADRA)
- // PARALELISMO
- REDONDEZ (CIRCULARIDAD)
- ⊘ CILINDRICIDAD
- △ PERFIL DE CUALQUIER SUPERFICIE
- ∧ PERFIL DE CUALQUIER LINEA
- ∧ VARIACION
- ⊕ POSICION REAL
- ⊙ CONCENTRICIDAD
- = SIMETRIA

ASME Y14.5M 1994

A MENOS QUE SE ESPECIFIQUE DE OTRA MANERA, LAS TOLERANCIAS DE LAS DIMS; SON LAS SIGUIENTES:

	PULG	±.1	±.02	±.005	±.0005
	mm	±0.5	±0.13	±0.013	

ANG. ±.50 GRADOS
ELIMINAR REBABAS Y ORILLAS FILOSAS DEL BORDE.
PULG .003-.015 mm 0.1-0.4
FILETEAR ESQUINA: PULG .020 mm 0.5
MAQUINAR SUPERFICIES
PULG 125 mm .32

DIMS METRICAS MOSTRADAS [PARENTESIS]

DIBUJADO POR:	ADRIAN DE LUNA	03-14-2011
APROBADO POR:	SAMUEL JIMENEZ	03-14-2011
TERCER ANGULO DE PROYECCION	⊕	FECHA EDS: 11-11-2011 REV. FORMATO: G
CONFIDENCIAL: ESTE DIBUJO Y SU INFORMACION SON PROPIEDAD DE USO EXCLUSIVO Y CONFIDENCIAL DE REGAL-BELOIT CORPORATION. Y NO DEBERAN SER REVELADOS, DUPLICADOS, DISTRIBUIDOS O USARSE DE OTRA MANERA SIN EL CONSENTIMIENTO ESCRITO DE REGAL-BELOIT CORPORATION. -TODOS LOS DERECHOS RESERVADOS.		

DESCRIPCION: OUTLINE	
TAMAÑO: C	NUMERO DE DIBUJO: C218
ESCALA: NONE	HOJA: 1

4

3

2

1

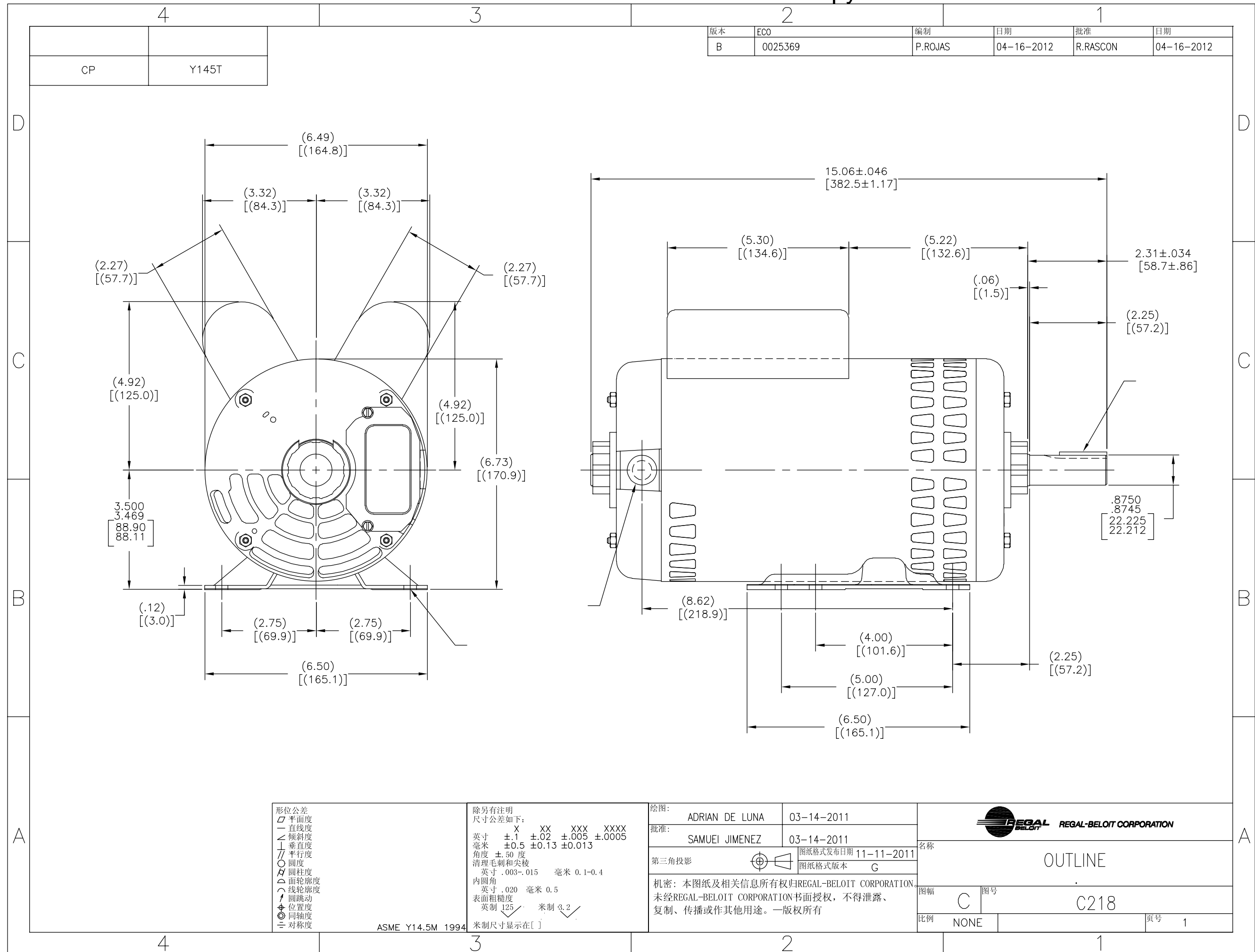

版本	ECO	编制	日期	批准	日期
B	0025369	P.ROJAS	04-16-2012	R.RASCON	04-16-2012

CP	Y145T
----	-------

形位公差

- 平面度
- 直线度
- ∠ 倾斜度
- ⊥ 垂直度
- // 平行度
- 圆度
- ⊘ 圆柱度
- △ 面轮廓度
- ∩ 线轮廓度
- ↗ 圆跳动
- ⊕ 位置度
- ⊙ 同轴度
- ≡ 对称度

ASME Y14.5M 1994

除另有注明
尺寸公差如下:

英寸	±.1	±.02	±.005	±.0005
毫米	±0.5	±0.13	±0.013	

角度 ±.50 度
清理毛刺和尖棱
英寸 .003-.015 毫米 0.1-0.4
内圆角
英寸 .020 毫米 0.5
表面粗糙度
英制 125 米制 3.2

米制尺寸显示在 []

绘图: ADRIAN DE LUNA 03-14-2011

批准: SAMUEI JIMENEZ 03-14-2011

第三角投影

机密: 本图纸及相关信息所有权归REGAL-BELOIT CORPORATION. 未经REGAL-BELOIT CORPORATION书面授权, 不得泄露、复制、传播或作其他用途。—版权所有

名称: OUTLINE

图幅: C 图号: C218

比例: NONE 页号: 1

REGAL-BELOIT CORPORATION