

# PRODUCT INFORMATION PACKET



Model No: C315ES  
Catalog No: C315ES

General Purpose Motor, 1/2 HP, 1 Ph, 60 Hz, 115/230 V, 1800 RPM, 56C Frame, DP



Regal and Century are trademarks of Regal Rexnord Corporation or one of its affiliated companies.  
©2022 Regal Rexnord Corporation, All Rights Reserved. MC017097E





**Nameplate Specifications**

Output HP	1/2 Hp	Output KW	0.37 kW
Frequency	60 Hz	Voltage	115/230 V
Current	4.6/2.3 A	Speed	1725 rpm
Service Factor	1.25	Phase	1
Duty	Continuous	Insulation Class	B
Frame	56C	Enclosure	Drip Proof
Thermal Protection	No Protection	Ambient Temperature	40 °C
UL	Recognized	CSA	Y
CE	Y	Number of Speeds	1

**Technical Specifications**

Electrical Type	Capacitor Start Capacitor Run	Starting Method	Across The Line
Poles	4	Rotation	Reversible Counterclockwise
Mounting	Round	Drive End Bearing	Ball
Opp Drive End Bearing	Ball	Frame Material	Rolled Steel
Shaft Type	Keyed	Overall Length	11.44 in
Frame Length	7.63 in	Shaft Diameter	0.625 in
Shaft Extension	2.06 in		
Outline Drawing	SS404112	Connection Drawing	9513517

This is an uncontrolled document once printed or downloaded and is subject to change without notice. Date Created:11/29/2022

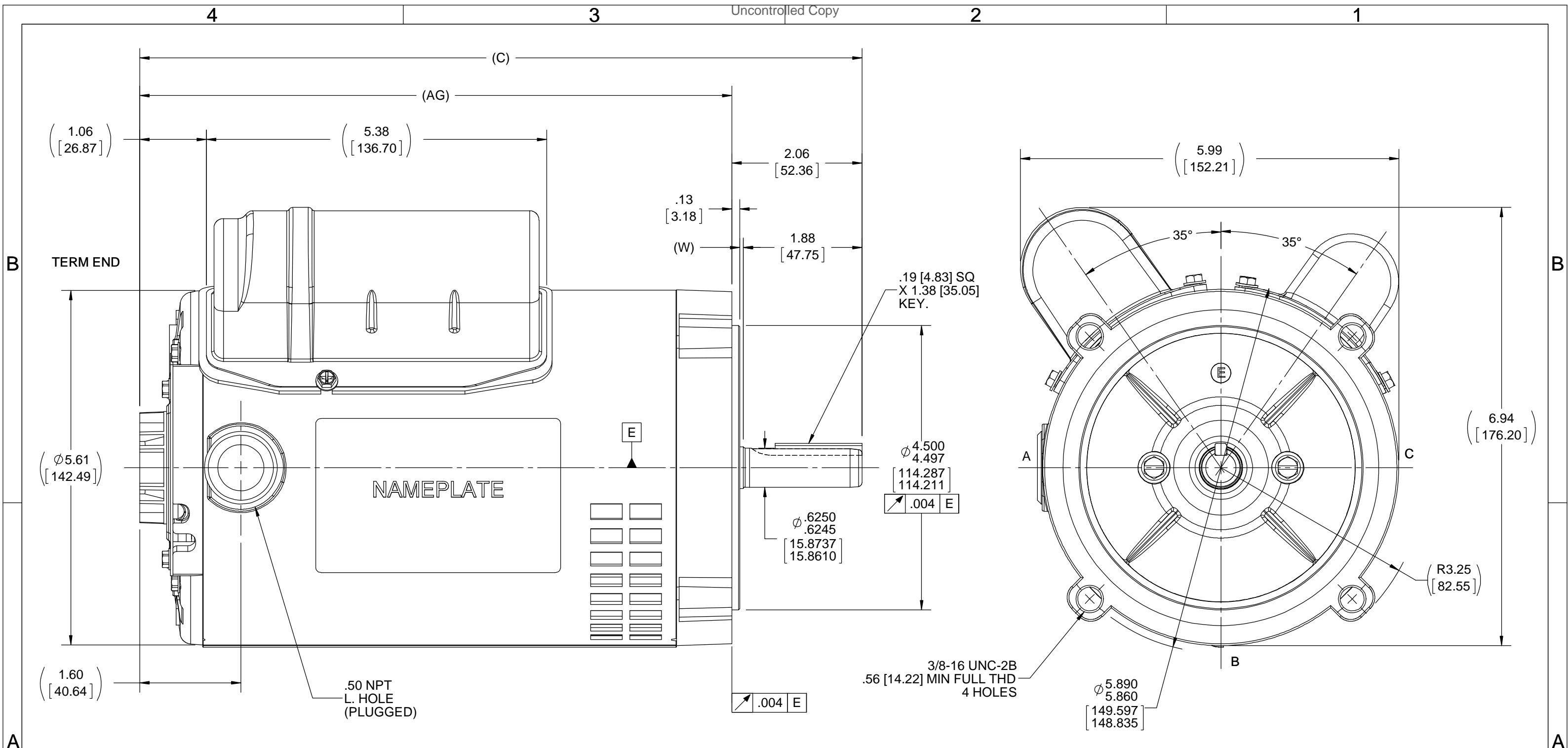

DASH	"C"	"AG"
625	10.18 [258.57]	8.12 [206.25]
650	10.43 [264.92]	8.37 [212.59]
675	10.68 [271.27]	8.62 [218.95]
700	10.93 [277.62]	8.87 [225.29]
725	11.18 [283.97]	9.12 [231.65]
750	11.43 [290.32]	9.37 [237.99]
775	11.68 [283.97]	9.62 [244.35]
800	11.93 [290.32]	9.87 [250.69]

NOTE:-  
 1) NAMEPLATE LOCATION AT "A" READ FROM TERM.END.  
 2) "W"-CLEARANCE ALLOWED FOR ALL VARIANCES IN MANUFACTURING & ASSEMBLY.

DRAWING REVISION D	REVISION BY A SUPPANAVAR	DATE 11/12/2018	TOLERANCES UNLESS OTHERWISE SPECIFIED: DEC. INCH mm ANGLE .X ±0.1 [±2.5] ±7° 30" .XX ±0.03 [±0.76] .XXX ±0.005 [±0.127] .XXXX ±0.0005 [±0.0127] REMOVE BURRS & BREAK SHARP EDGES: .003/.015 [.076/.381] X 45° CORNER FILLETS: R.02 [.51] MACHINED SURFACES: 200 INCH/mm 5.1 mm SHOWN IN [BRACKETS]	DRAWN BY JAH	Regal Beloit America, Inc.	
ECO ECO-0157672	APPROVED BY J DAS	DATE 12/03/2018		DATE 11/17/2014		
ECO DESCRIPTION <b>OUTLINE CONVERSION PROJECT</b> <small>COPYRIGHT REGAL BELOIT AMERICA, INC. ALL RIGHTS RESERVED. PROPRIETARY AND CONFIDENTIAL INFORMATION - THIS DOCUMENT IS THE PROPERTY OF REGAL BELOIT AMERICA, INC. ("OWNER") AND CONTAINS OWNER'S PROPRIETARY INFORMATION. ANY PERSON, CORPORATION OR OTHER FIRM RECEIVING IT IS DEEMED, BY RECEIVING IT, TO AGREE THAT IT, AND/OR ANY PART OF IT, SHALL NOT BE DISCLOSED TO ANY PERSON, CORPORATION OR OTHER ENTITY, DUPLICATED, AND/OR USED, EXCEPT AS EXPRESSLY APPROVED IN WRITING IN ADVANCE BY OWNER. THIS DOCUMENT SHALL BE RETURNED TO OWNER UPON REQUEST. IT MAY BE SUBJECT TO CERTAIN RESTRICTIONS UNDER APPLICABLE EXPORT CONTROL LAWS AND REGULATIONS.</small>			REFERENCE SS404112	DESCRIPTION <b>OUTLINE</b>	PROCESS/FINISH	
			THIRD ANGLE PROJECTION	SIZE B	DRAWING NUMBER <b>SS404112</b>	SHEET 1 OF 1

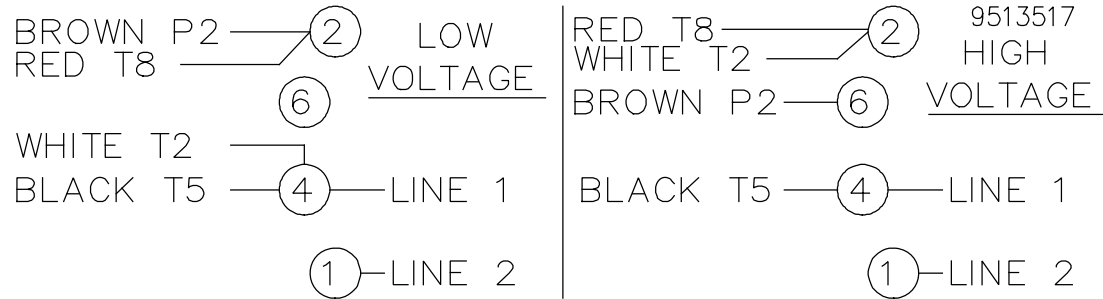

ROTATION CCW-OPE TO REVERSE EITHER VOLTAGE  
 INTERCHANGE BLACK(T5) WITH RED(T8) LEADS

				TOLERANCES UNLESS SPECIFIED			DRAWN TOM 06-21-1988		
				DEC.	INCHES		CHK	GK 06-21-1988	
				.X	±.1		APPD	FG 06-21-1988	
3	ADDED T MARKINGS	DS	07/19/2018	VC	.XX ±.02	TITLE CONNECTION DIAGRAM	SCALE 1=1		
2	REDRAWN IN AUTOCAD	TAT	10-22-2004	ML	.XXX ±.005		REF		
1	NEW DRAWING	TOM	06-24-1988		.XXXX ±.0005		FMF		
NO.	REVISION	BY & DATE	CHK	ANG	±7'30"	FINISH	PREV		
THIS DRAWING IN DESIGN AND DETAIL IS OUR PROPERTY AND MUST NOT BE USED EXCEPT IN CONNECTION WITH OUR WORK ALL RIGHTS OF DESIGN AND INVENTION ARE RESERVED THIS IS AN ELECTRONICALLY GENERATED DOCUMENT - DO NOT SCALE THIS PRINT				RFP	CAD FILE 9513517		SIZE	DRAWING NO. PAGE OF	REV.
				DIST			A	9513517 3	3