

# PRODUCT INFORMATION PACKET



Model No: C420ES  
Catalog No: C420ES  
General Purpose Motor, .50 HP, 1 Ph, 60 Hz, 115/230 V, 1200 RPM, 56 Frame, ODP



Regal and Century are trademarks of Regal Rexnord Corporation or one of its affiliated companies.  
©2022 Regal Rexnord Corporation, All Rights Reserved. MC017097E





**Nameplate Specifications**

Output HP	.50 Hp	Output KW	0.37 kW
Frequency	60 Hz	Voltage	115/230 V
Current	5.6/2.8 A	Speed	1140 rpm
Service Factor	1.25	Phase	1
Duty	Continuous	Insulation Class	B
Frame	56	Enclosure	Open Drip Proof
Thermal Protection	No Protection	Ambient Temperature	40 °C
UL	Recognized	CSA	Y
CE	Y	Number of Speeds	1

**Technical Specifications**

Electrical Type	Capacitor Start Capacitor Run	Starting Method	Across The Line
Poles	6	Rotation	Counterclockwise
Mounting	Rigid Base	Drive End Bearing	Ball
Opp Drive End Bearing	Ball	Frame Material	Rolled Steel
Shaft Type	Keyed	Overall Length	12.15 in
Frame Length	6.25 in	Shaft Diameter	0.625 in
Shaft Extension	1.97 in		
Connection Drawing	D0000435-001	Outline Drawing	C420ES-S01

This is an uncontrolled document once printed or downloaded and is subject to change without notice. Date Created:11/29/2022

ALL DIMENSIONS SHOWN IN PARENTHESIS ARE REFERENCE DIMENSIONS. ALL OTHER DIMENSIONS ARE TOLERANCED PER THE FOLLOWING CHART UNLESS OTHERWISE SPECIFIED.

"OVERALL" DIMENSION	= ±.055[1.397]
SHAFT EXTENSION	= ±.034[.864]
LEAD LENGTHS	= ±1.00[25.40]
EXTENDED THRU-BOLTS	= ±.050[1.270]
ANGULAR DIMENSIONS	= ±2°

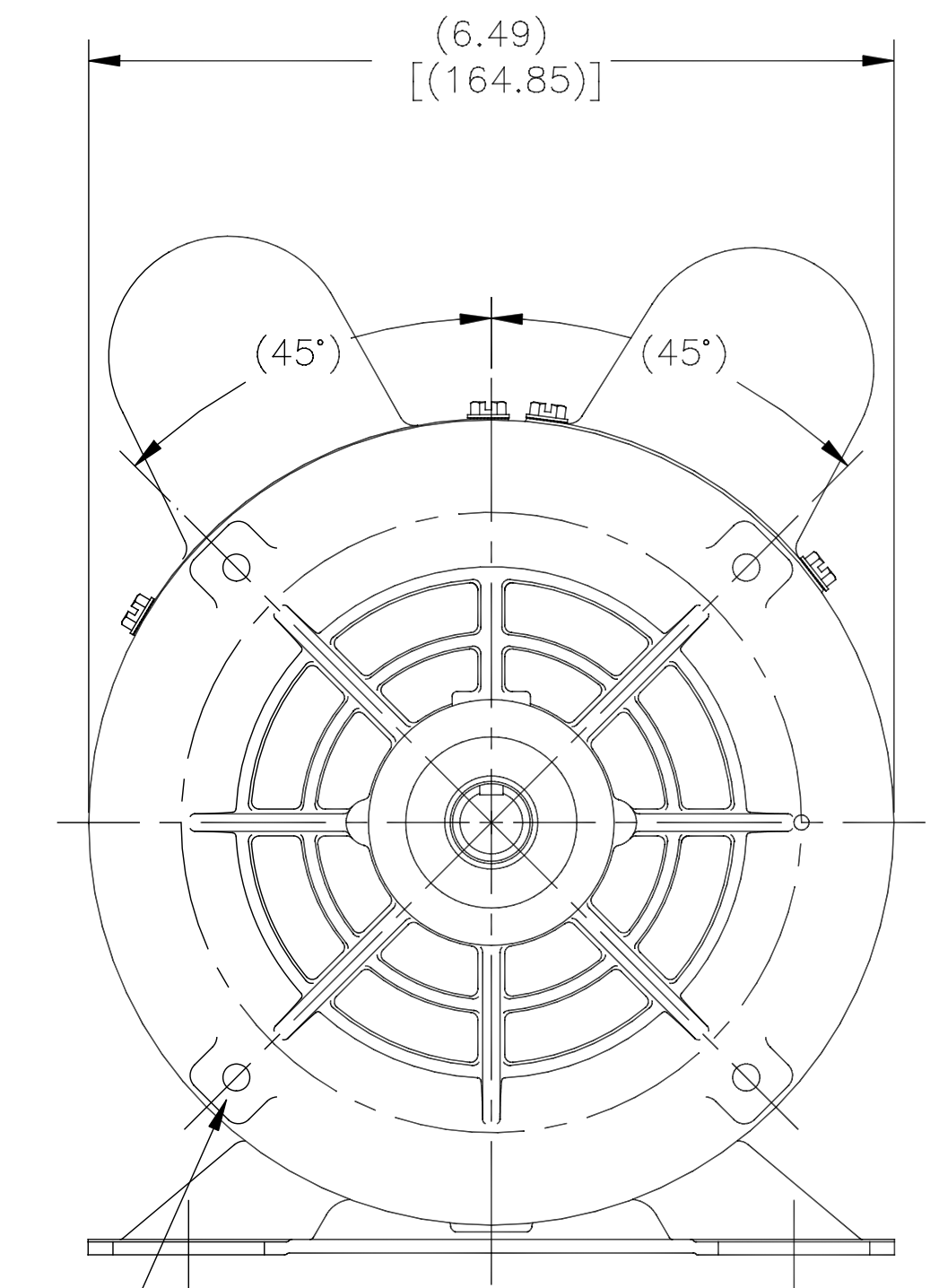
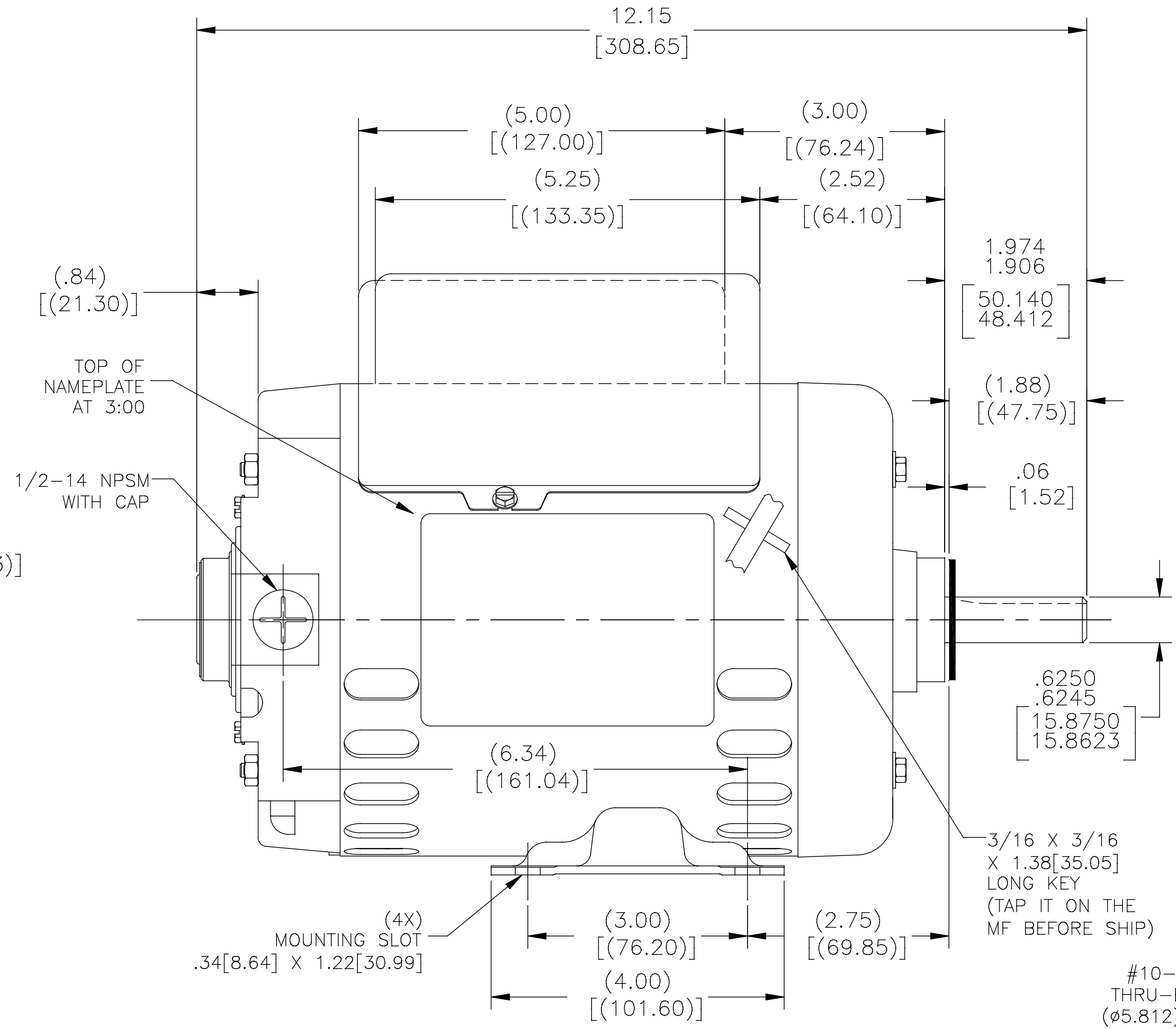
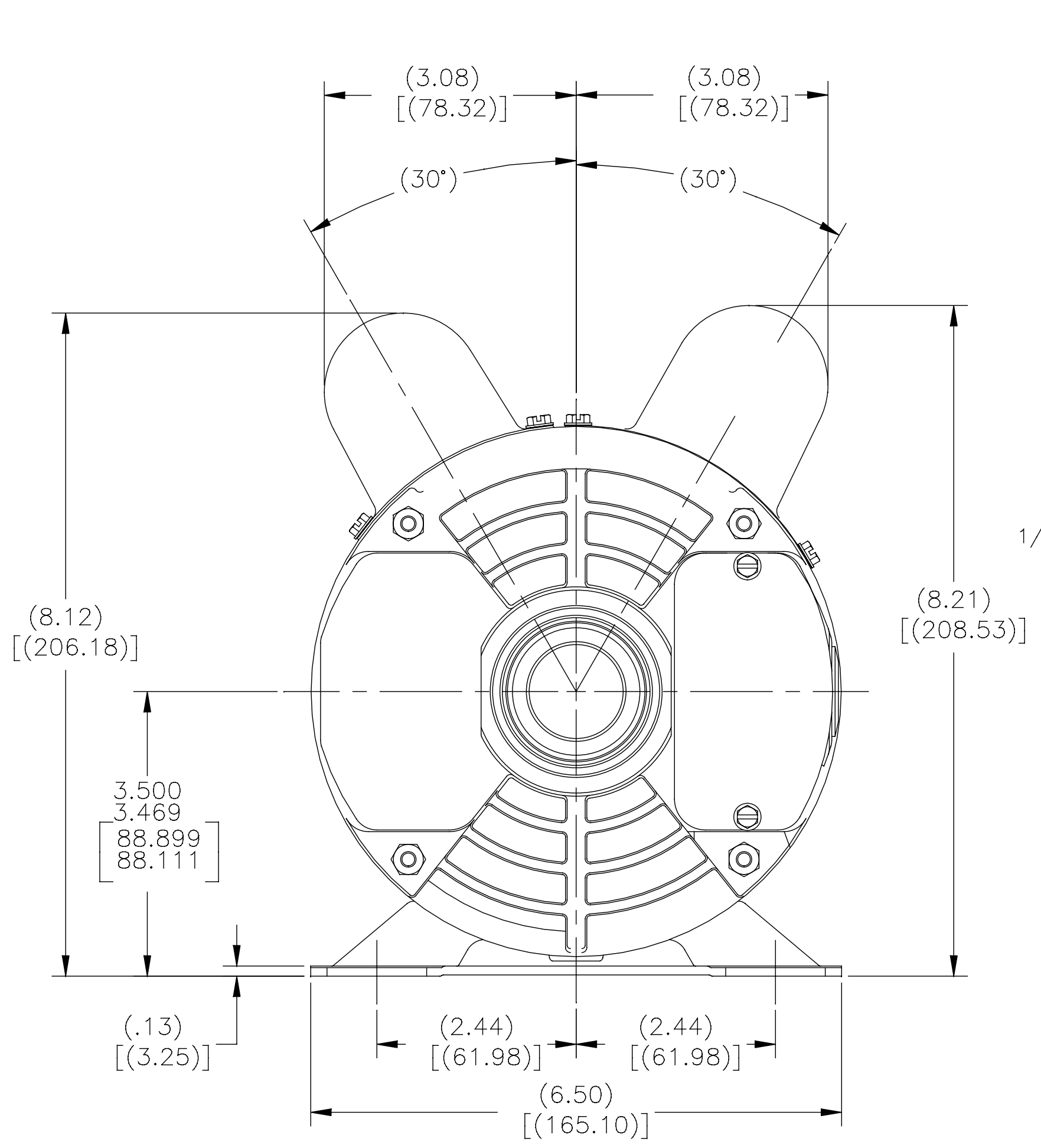

DRAWING REVISION B	REVISION BY J.YAO	DATE 06-25-2015	TOLERANCES UNLESS OTHERWISE SPECIFIED DEC INCH mm ANGLE X ±0.1 [±2.5] ±0.5° XX ±0.02 [±0.51] XXX ±0.005 [±0.127] XXXX ±0.0005 [±0.0127]	DRAWN BY J.YAO	DATE 10-15-2014	DESCRIPTION MODEL-CFHP-56FR OUTLINE
ECO-0079651	APPROVED BY H.ZHANG	DATE 06-25-2015	REMOVE BURRS & BREAK SHARP EDGES .003/0.15 [0.076/3.81]	APPROVED BY D.ZHANG	DATE 10-15-2014	MATERIAL C420ES
ECO DESCRIPTION SPE ECO	COPYRIGHT REGAL BELLOIT AMERICA, INC. ALL RIGHTS RESERVED. REGAL BELLOIT AMERICA, INC. (PARENT) AND CONTIGUOUS OWNERS' PROPRIETARY INFORMATION OR TRADE SECRETS ARE HEREBY PROTECTED AND WILL BE KEPT AS SUCH. NO PART OF THIS DOCUMENT SHALL BE REPRODUCED OR TRANSMITTED IN ANY FORM OR BY ANY MEANS, ELECTRONIC OR MECHANICAL, INCLUDING PHOTOCOPYING, RECORDING, OR BY ANY INFORMATION STORAGE AND RETRIEVAL SYSTEM, WITHOUT THE WRITTEN PERMISSION OF REGAL BELLOIT AMERICA, INC. THIS DOCUMENT IS THE PROPERTY OF REGAL BELLOIT AMERICA, INC. IT IS TO BE USED ONLY FOR THE PROJECT AND FOR THE CUSTOMER'S USE ONLY. IT IS NOT TO BE DISTRIBUTED TO ANY OTHER PERSON OR ENTITY WITHOUT THE WRITTEN PERMISSION OF REGAL BELLOIT AMERICA, INC.		CORNER FILLETS .02 [51]	PROCESS/FINISH	THIRD ANGLE PROJECTION	SIZE DWG NO C420ES
			MACHINED SURFACES INCH mm mm SHOWN IN [BRACKETS]			SHEET 1

4

3

2

1

REV	ECO	REV BY	DATE	APPD	DATE
A	ECO-0028953	A.BAUGHMAN	11-09-2012	A.BAUGHMAN	11-09-2012

D

D

C

C

B

B

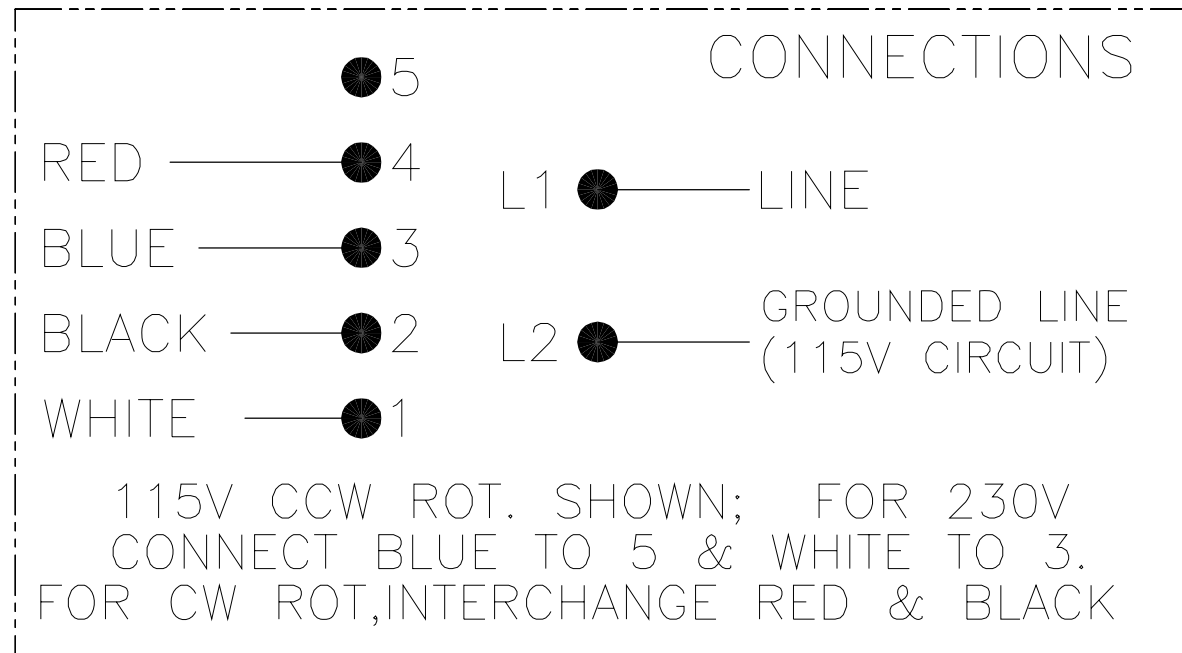

A

A

4

3

2

1

GEOMETRIC CHARACTERISTICS & SYMBOLS □ FLATNESS — STRAIGHTNESS ∠ ANGULARITY ⊥ PERPENDICULARITY (SQUARENESS) // PARALLELISM ○ ROUNDNESS (CIRCULARITY) ∅ CYLINDRICITY △ PROFILE OF ANY SURFACE ∩ PROFILE OF ANY LINE ↗ RUNOUT ⊕ TRUE POSITION ⊙ CONCENTRICITY = SYMMETRY ASME Y14.5M 1994	UNLESS OTHERWISE SPECIFIED DIM. TOLERANCES ARE AS FOLLOWS: INCH X XX XXX XXXX ±.1 ±.02 ±.005 ±.0005 mm ±0.5 ±0.13 ±0.013 ANG. ±.50 DEG REMOVE BURRS & BREAK SHARP EDGES: INCH .003-.015 mm 0.1-0.4 CORNER FILLETS TO: INCH .020 mm 0.5 MACHINE SURFACES: INCH 125 mm 3.2 METRIC DIMS. SHOWN IN [BRACKETS]	DR BY: A.BAUGHMAN	11-09-2012	<b>REGAL-BELOIT CORPORATION</b>
		APPD: A.BAUGHMAN	11-09-2012	
		THIRD ANGLE PROJECTION	EDS DATE 11-11-2011 FORMAT REV H	SIZE C DWG NO D0000435-001
		CONFIDENTIAL: THIS DRAWING AND ITS INFORMATION ARE THE EXCLUSIVE AND CONFIDENTIAL PROPERTY OF REGAL-BELOIT CORPORATION AND ARE NOT TO BE DISCLOSED, DUPLICATED, DISTRIBUTED OR OTHERWISE USED WITHOUT THE WRITTEN CONSENT OF REGAL-BELOIT CORPORATION. -ALL RIGHTS RESERVED.		SCALE NONE SHEET 1

4

3

2

1

REVISION:	ECO	REVISADO POR:	FECHA:	APROBADO POR:	FECHA:
A	ECO-0028953	A.BAUGHMAN	11-09-2012	A.BAUGHMAN	11-09-2012

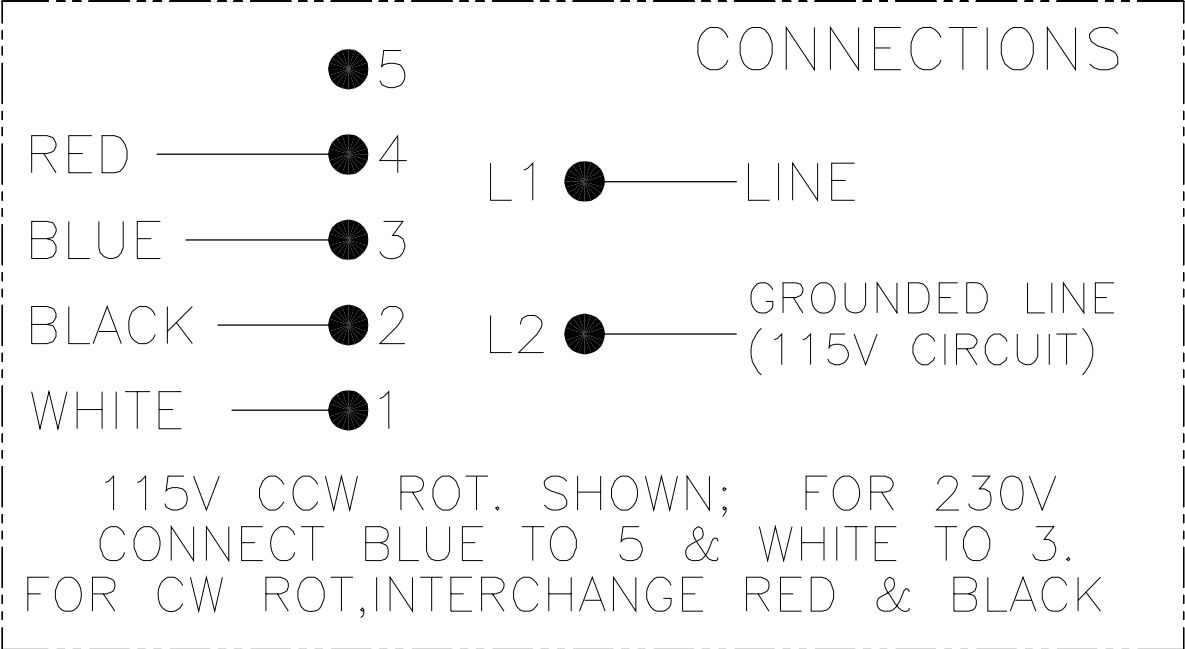

CARACTERISTICAS DE GEOMETRIA Y SIMBOLOS

- ▢ PLANICIDAD
- RECTITUD
- ∠ ANGULARIDAD
- ⊥ PERPENDICULARIDAD (A ESCUADRA)
- // PARALELISMO
- REDONDEZ (CIRCULARIDAD)
- ∅ CILINDRICIDAD
- △ PERFIL DE CUALQUIER SUPERFICIE
- ∩ PERFIL DE CUALQUIER LINEA
- ∠ VARIACION
- ⊕ POSICION REAL
- ◎ CONCENTRICIDAD
- ≡ SIMETRIA

ASME Y14.5M 1994

A MENOS QUE SE ESPECIFIQUE DE OTRA MANERA, LAS TOLERANCIAS DE LAS DIMS; SON LAS SIGUIENTES:

	X	XX	XXX	XXXX
PULG	±.1	±.02	±.005	±.0005
mm	±0.5	±0.13	±0.013	
ANG.	± 50 GRADOS			
ELIMINAR REBABAS Y ORILLAS FILOSAS DEL BORDE.				
	PULG .003-.015	mm 0.1-0.4		
FILETEAR ESQUINA:	PULG .020 mm 0.5			
MAQUINAR SUPERFICIES	PULG 125 mm 3.2			

DIMS METRICAS MOSTRADAS [PARENTESIS]

DIBUJADO POR:	A.BAUGHMAN	11-09-2012
APROBADO POR:	A.BAUGHMAN	11-09-2012
TERCER ANGULO DE PROYECCION		FECHA EDS: 11-11-2011 REV. FORMATO: H
CONFIDENCIAL: ESTE DIBUJO Y SU INFORMACION SON PROPIEDAD DE USO EXCLUSIVO Y CONFIDENCIAL DE REGAL-BELOIT CORPORATION. Y NO DEBERAN SER REVELADOS, DUPLICADOS, DISTRIBUIDOS O USARSE DE OTRA MANERA SIN EL CONSENTIMIENTO ESCRITO DE REGAL-BELOIT CORPORATION. -TODOS LOS DERECHOS RESERVADOS.		

<b>REGAL REGAL-BELOIT CORPORATION</b>	
DESCRIPCION: CONN DIAGRAM-NAMEPLATE	
TAMAÑO: C	NUMERO DE DIBUJO: D0000435-001
ESCALA: NONE	HOJA: 1

4

3

2

1

4

3

2

1

版本	ECO	编制	日期	批准	日期
A	ECO-0028953	A.BAUGHMAN	11-09-2012	A.BAUGHMAN	11-09-2012

D

D

C

C

B

B

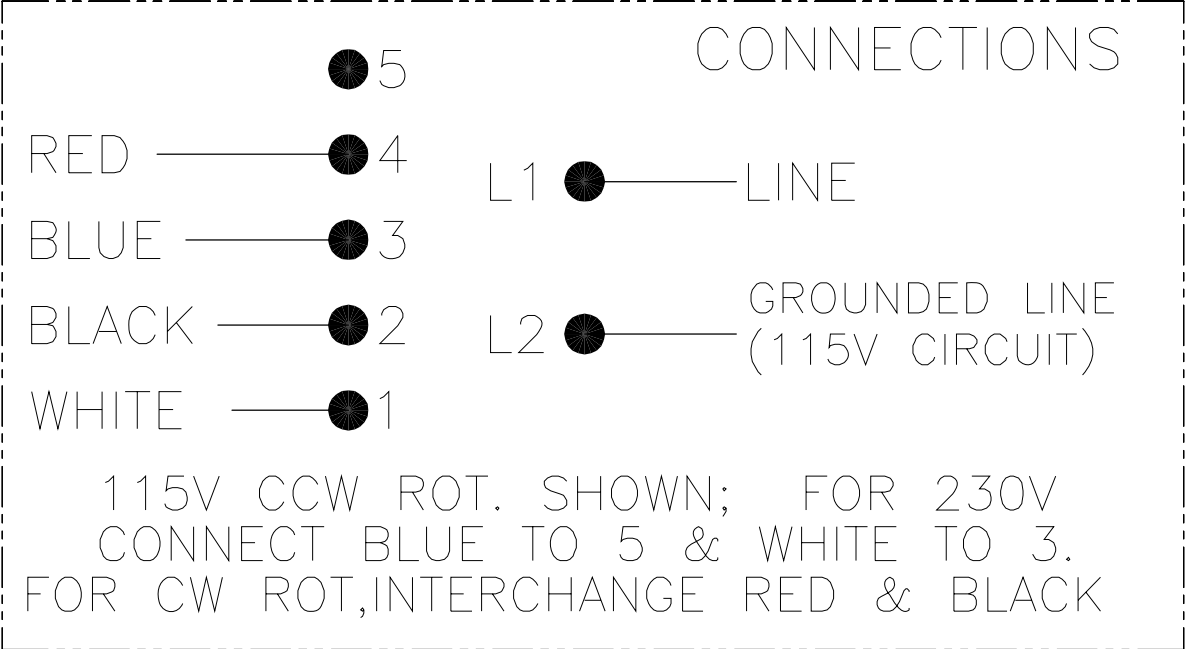

A

A

4

3

2

1

形位公差 □ 平面度 — 直线度 < 倾斜度 ⊥ 垂直度 // 平行度 ○ 圆度 ⊙ 圆柱度 ⌒ 面轮廓度 △ 线轮廓度 ⤴ 圆跳动 ⊕ 位置度 ⊗ 同轴度 ≡ 对称度	除另有注明 尺寸公差如下: 英寸 X XX XXX XXXX 毫米 ±.1 ±.02 ±.005 ±.0005 毫米 ±0.5 ±0.13 ±0.013 角度 ±.50 度 清理毛刺和尖棱 英寸 .003-.015 毫米 0.1-0.4 内圆角 英寸 .020 毫米 0.5 表面粗糙度 英制 125 米制 3.2 米制尺寸显示在L	绘图:	A.BAUGHMAN	11-09-2012	<b>REGAL-BELOIT CORPORATION</b>			
		批准:	A.BAUGHMAN	11-09-2012		名称	CONN DIAGRAM-NAMEPLATE	
		第三角投影		图纸格式发布日期 11-11-2011	图幅	C	图号	D0000435-001
		机密: 本图纸及相关信息所有权归REGAL-BELOIT CORPORATION 未经REGAL-BELOIT CORPORATION书面授权, 不得泄露、 复制、传播或作其他用途。—版权所有		比例	NONE	页号	1	