

# PRODUCT INFORMATION PACKET



Model No: C472A

Catalog No: C472A

Fan and Blower Motor, 1.0-1/3 HP, 1 Ph, 60 Hz, 208/230 V, 1800 RPM, M56 Frame, DP



Regal and Century are trademarks of Regal Rexnord Corporation or one of its affiliated companies.

©2023 Regal Rexnord Corporation, All Rights Reserved. MC017097E





### Nameplate Specifications

Output HP	1.0-1/3 Hp	Output KW	0.75 kW
Frequency	60 Hz	Voltage	208/230 V
Current	6.4-6.0/3.4-3.5 A	Speed	1725/1160 rpm
Service Factor	1.15	Phase	1
Duty	Continuous	Insulation Class	B
Frame	M56	Enclosure	Drip Proof
Thermal Protection	Thermally Protected	Ambient Temperature	40 °C
UL	Recognized	CSA	Y
CE	N	Number of Speeds	2-2-VT

### Technical Specifications

Electrical Type	Capacitor Start, Induction Run, Special Service, Multi-Speed	Starting Method	Across The Line
Poles	4/6	Rotation	Reversible Counterclockwise
Mounting	Cushion Base	Drive End Bearing	Ball
Opp Drive End Bearing	Ball	Frame Material	Rolled Steel
Shaft Type	Keyed	Overall Length	12.69 in
Frame Length	6.75 in	Shaft Diameter	0.625 in
Shaft Extension	1.94 in		
Outline Drawing	190604-002-S02	Connection Drawing	17050311.PCX

This is an uncontrolled document once printed or downloaded and is subject to change without notice. Date Created:03/15/2023

REV	ECO	REV BY	DATE	APPD	DATE
B	0025371	I.MATA	04-13-2012	R.RASCON	04-13-2012

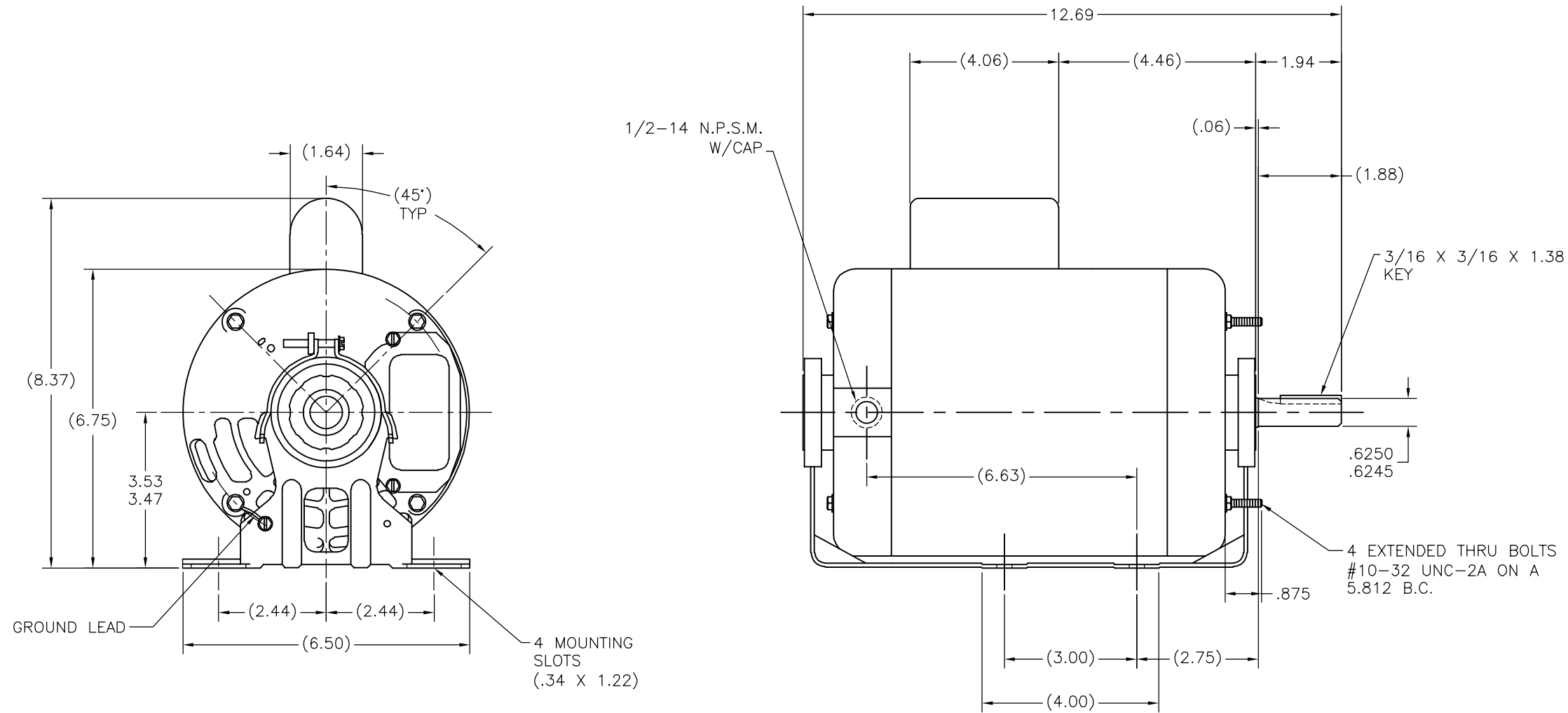

GEOMETRIC CHARACTERISTICS & SYMBOLS

- FLATNESS
- STRAIGHTNESS
- ∠ ANGULARITY
- ⊥ PERPENDICULARITY (SQUARENESS)
- // PARALLELISM
- ROUNDNESS (CIRCULARITY)
- ⊘ CYLINDRICITY
- △ PROFILE OF ANY SURFACE
- ∩ PROFILE OF ANY LINE
- ↗ RUNOUT
- ⊕ TRUE POSITION
- ◎ CONCENTRICITY
- ≡ SYMMETRY

ASME Y14.5M 1994

UNLESS OTHERWISE SPECIFIED  
DIM. TOLERANCES ARE AS FOLLOWS:

INCH	±.1	±.02	±.005	±.0005
mm	±0.5	±0.13	±0.013	

ANG. ±.50 DEG  
REMOVE BURRS & BREAK SHARP EDGES:  
INCH .003-.015 mm 0.1-0.4  
CORNER FILLETS TO:  
INCH .020 mm 0.5  
MACHINE SURFACES:  
INCH 125 mm 3.2

METRIC DIMS. SHOWN IN [BRACKETS]

DR BY: JBLANK 04-26-2005

APPD:

THIRD ANGLE PROJECTION

EDS DATE 11-11-2011  
FORMAT REV G

CONFIDENTIAL: THIS DRAWING AND ITS INFORMATION ARE THE EXCLUSIVE AND CONFIDENTIAL PROPERTY OF REGAL-BELOIT CORPORATION AND ARE NOT TO BE DISCLOSED, DUPLICATED, DISTRIBUTED OR OTHERWISE USED WITHOUT THE WRITTEN CONSENT OF REGAL-BELOIT CORPORATION. -ALL RIGHTS RESERVED.

REGAL-BELOIT CORPORATION

DESCRIPTION: OUTLINE

SIZE C DWG NO 19060401-002

SCALE NONE SHEET 2

4

3

2

1

REVISION:	ECO	REVISADO POR:	FECHA:	APROBADO POR:	FECHA:
B	0025371	I.MATA	04-13-2012	R.RASCON	04-13-2012

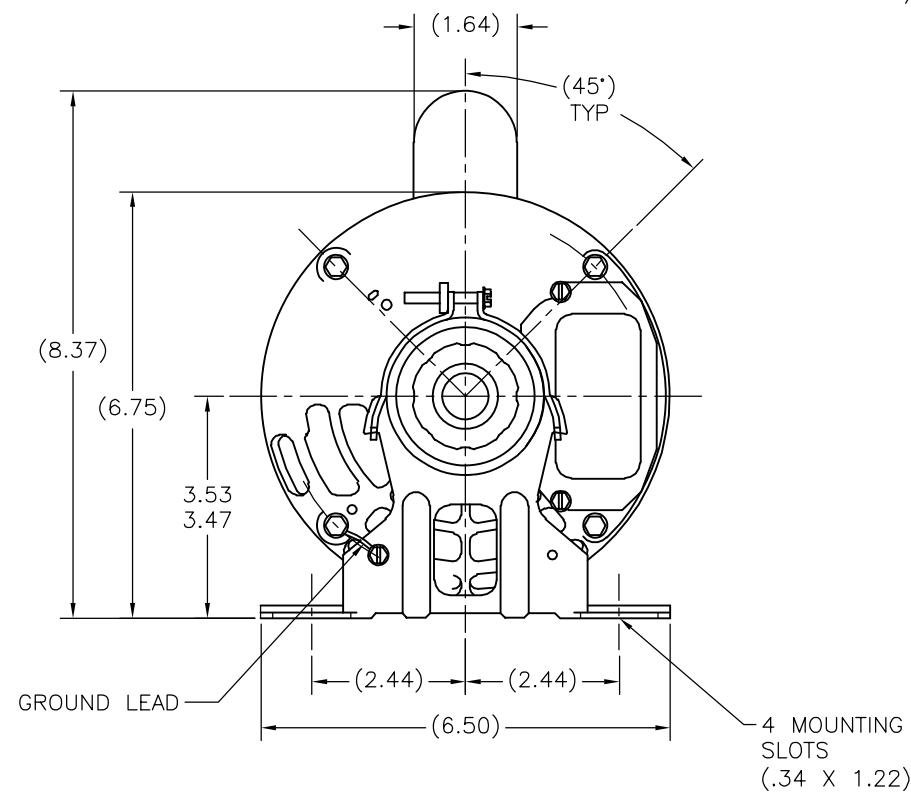

1/2-14 N.P.S.M.  
W/CAP

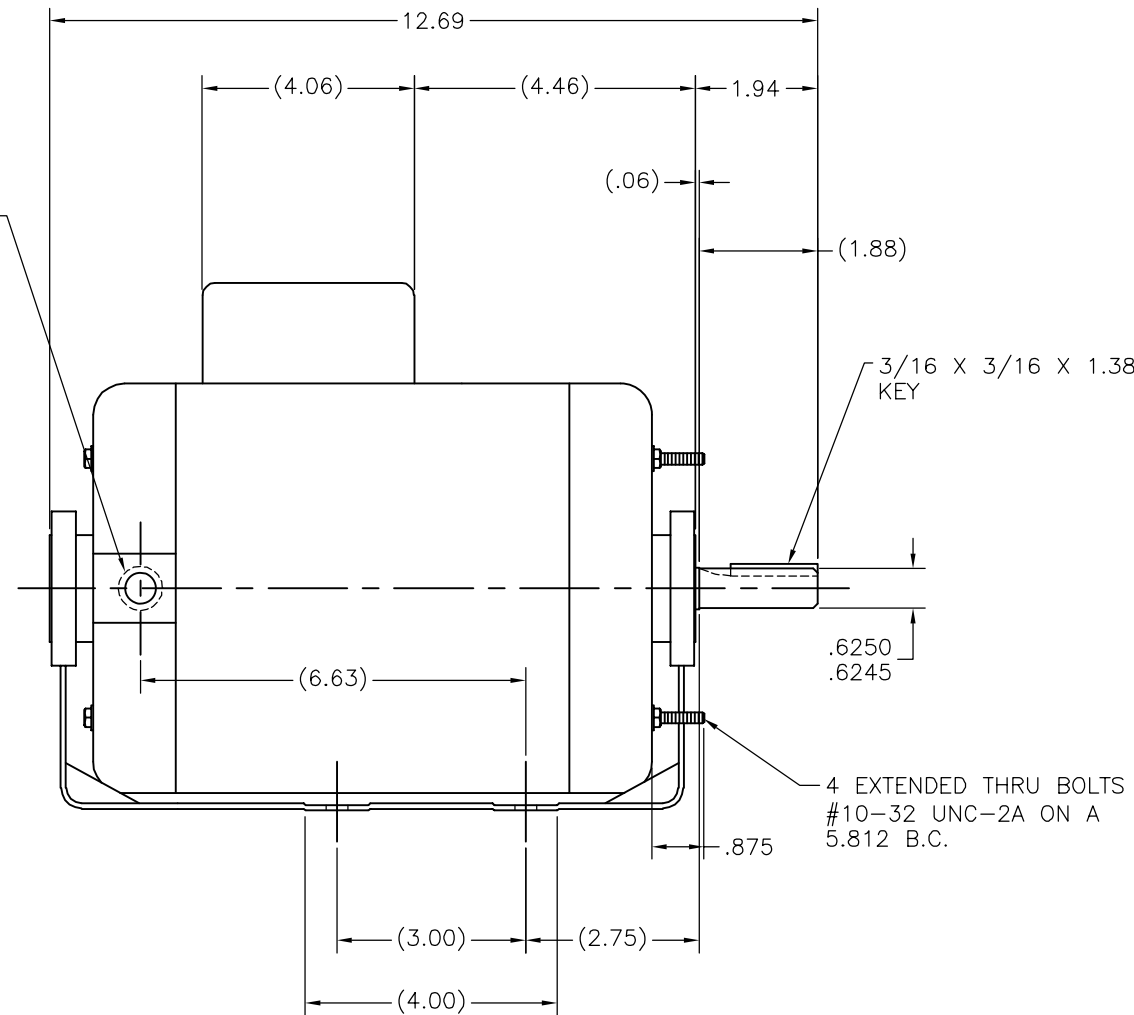

CARACTERISTICAS DE GEOMETRIA Y SIMBOLOS

- PLANICIDAD
- RECTITUD
- ∠ ANGULARIDAD
- ⊥ PERPENDICULARIDAD (A ESCUADRA)
- // PARALELISMO
- REDONDEZ (CIRCULARIDAD)
- ∅ CILINDRICIDAD
- △ PERFIL DE CUALQUIER SUPERFICIE
- ∧ PERFIL DE CUALQUIER LINEA
- ↑ VARIACION
- ⊕ POSICION REAL
- ◎ CONCENTRICIDAD
- = SIMETRIA

ASME Y14.5M 1994

A MENOS QUE SE ESPECIFIQUE DE OTRA MANERA, LAS TOLERANCIAS DE LAS DIMS; SON LAS SIGUIENTES:

PULG	±.1	±.02	±.005	±.0005
mm	±0.5	±0.13	±0.013	

ANG. ±.50 GRADOS  
ELIMINAR REBABAS Y ORILLAS FILOSAS DEL BORDE.  
PULG .003-.015 mm 0.1-0.4  
FILETEAR ESQUINA: PULG .020 mm 0.5  
MAQUINAR SUPERFICIES  
PULG 125 mm .32

DIMS METRICAS MOSTRADAS [PARENTESIS]

DIBUJADO POR:	JBLANK	04-26-2005
APROBADO POR:		
TERCER ANGULO DE PROYECCION	⊕	FECHA EDS: 11-11-2011 REV. FORMATO: G
CONFIDENCIAL: ESTE DIBUJO Y SU INFORMACION SON PROPIEDAD DE USO EXCLUSIVO Y CONFIDENCIAL DE REGAL-BELOIT CORPORATION. Y NO DEBERAN SER REVELADOS, DUPLICADOS, DISTRIBUIDOS O USARSE DE OTRA MANERA SIN EL CONSENTIMIENTO ESCRITO DE REGAL-BELOIT CORPORATION. -TODOS LOS DERECHOS RESERVADOS.		

DESCRIPCION: <b>OUTLINE</b>	
TAMAÑO: C	NUMERO DE DIBUJO: 19060401-002
ESCALA: NONE	HOJA: 2

4

3

2

1

4

3

2

1

版本	ECO	编制	日期	批准	日期
B	0025371	I.MATA	04-13-2012	R.RASCON	04-13-2012

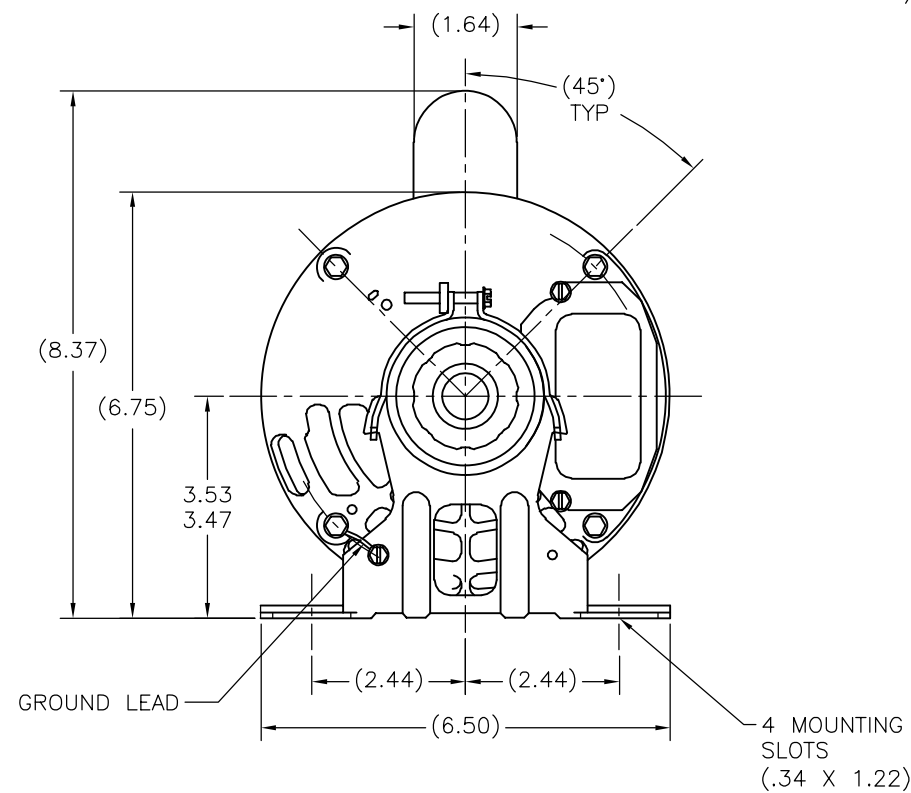

1/2-14 N.P.S.M.  
W/CAP

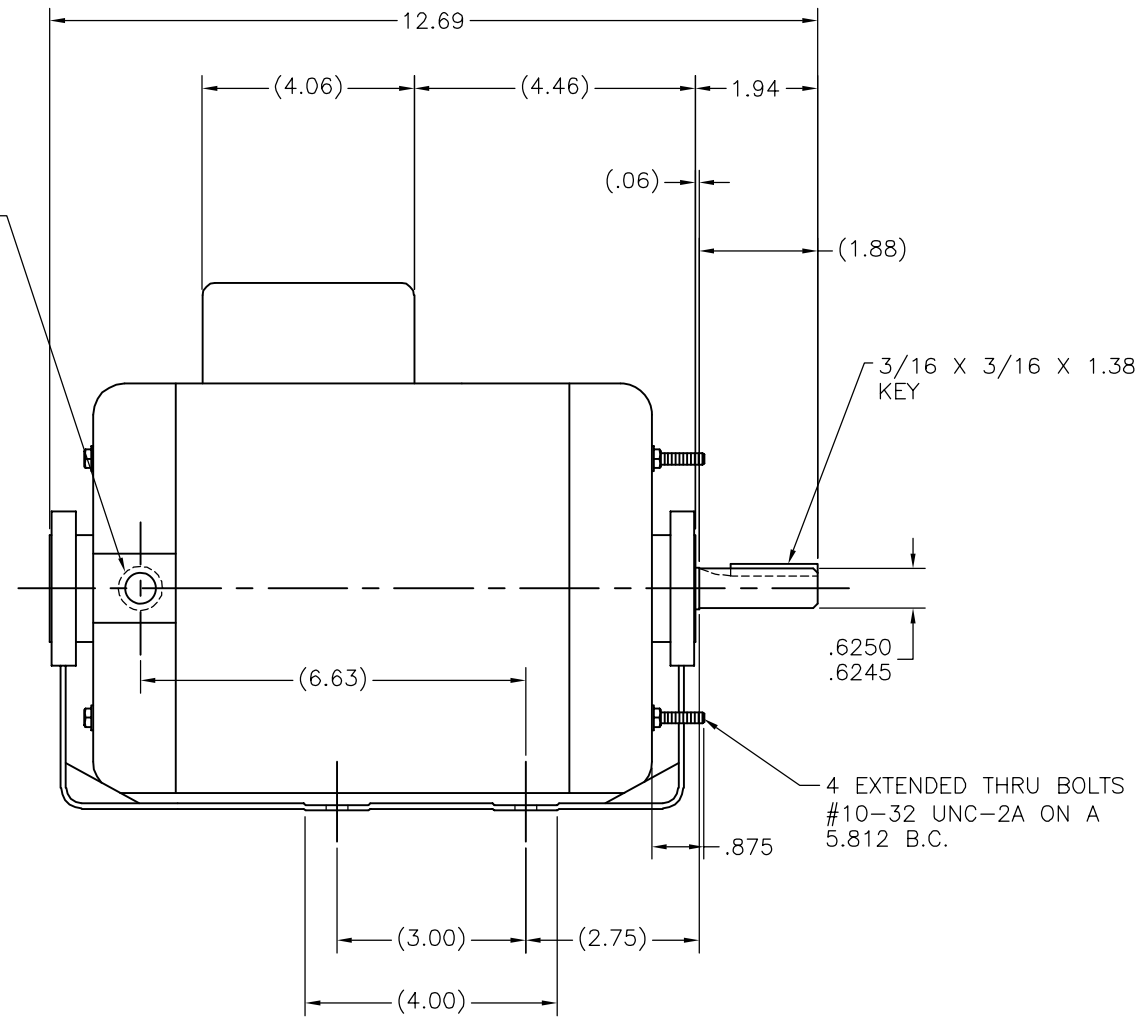

形位公差	除另有注明
□ 平面度	尺寸公差如下:
— 直线度	英寸 X XX XXX XXXX
∠ 倾斜度	英寸 ±.1 ±.02 ±.005 ±.0005
⊥ 垂直度	毫米 ±0.5 ±0.13 ±0.013
// 平行度	角度 ±.50 度
○ 圆度	清理毛刺和尖棱
⊘ 圆柱度	英寸 .003-.015 毫米 0.1-0.4
△ 面轮廓度	内圆角
∩ 线轮廓度	英寸 .020 毫米 0.5
↗ 圆跳动	表面粗糙度
⊕ 位置度	英制 125 米制 3.2
◎ 同轴度	米制尺寸显示在 [ ]
≡ 对称度	

ASME Y14.5M 1994

绘图:	JBLANK	04-26-2005
批准:		
第三角投影		图纸格式发布日期 11-11-2011 图纸格式版本 G
机密: 本图纸及相关信息所有权归REGAL-BELOIT CORPORATION 未经REGAL-BELOIT CORPORATION书面授权, 不得泄露、 复制、传播或作其他用途。一版权所有		



名称	OUTLINE	
图幅	C	图号 19060401-002
比例	NONE	页号 2

4

3

2

1