

PRODUCT INFORMATION PACKET



Model No: C741V2
Catalog No: C741V2
Fan and Blower Motor, .75/.33 HP, 1 Ph, 60 Hz, 115 V, 1800 RPM, 56 Frame, DP



Regal and Century are trademarks of Regal Rexnord Corporation or one of its affiliated companies.
©2023 Regal Rexnord Corporation, All Rights Reserved. MC017097E





Nameplate Specifications

Output HP	.75/.33 Hp	Output KW	0.56 kW
Frequency	60 Hz	Voltage	115 V
Current	8.6/6.1 A	Speed	1725/1140 rpm
Service Factor	1	Phase	1
Efficiency	72 %	Duty	Continuous
Insulation Class	F	Frame	56
Enclosure	Drip Proof	Thermal Protection	Thermally Protected
Ambient Temperature	40 °C	UL	Recognized
CSA	Y	CE	Y
Number of Speeds	2		

Technical Specifications

Electrical Type	Capacitor Start Induction Run	Starting Method	Across The Line
Poles	4/6	Rotation	Selective Counterclockwise
Mounting	Resilient Base	Drive End Bearing	Ball
Opp Drive End Bearing	Ball	Frame Material	Rolled Steel
Shaft Type	NEMA 56	Overall Length	11.97 in
Frame Length	7.65 in	Shaft Diameter	0.625 in
Shaft Extension	1.88 in		
Outline Drawing	OL56100498-001	Connection Drawing	DD10045-002

This is an uncontrolled document once printed or downloaded and is subject to change without notice. Date Created:03/15/2023

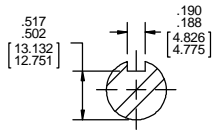
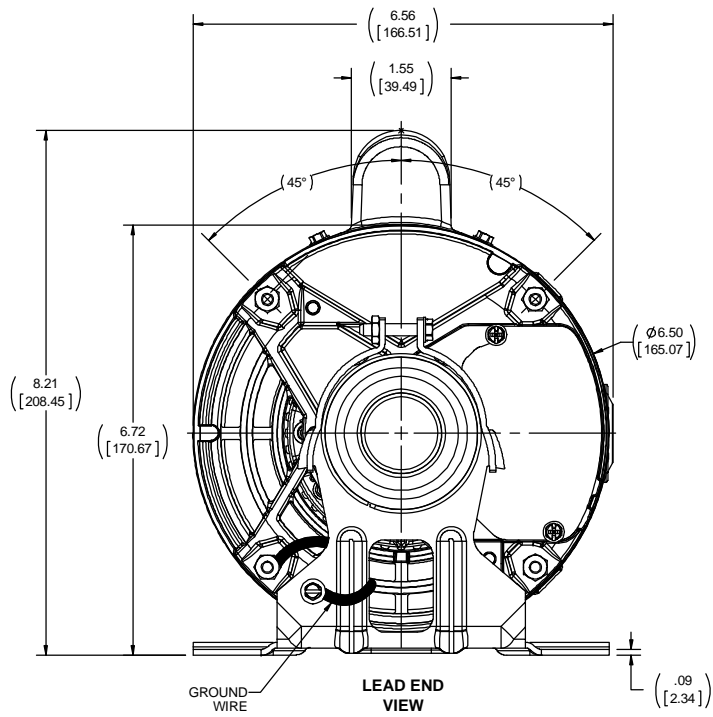

SECTION A-A

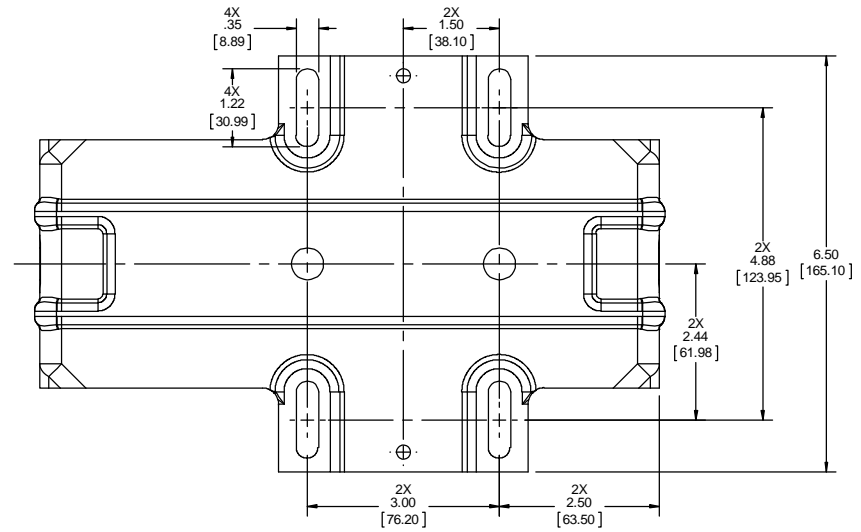
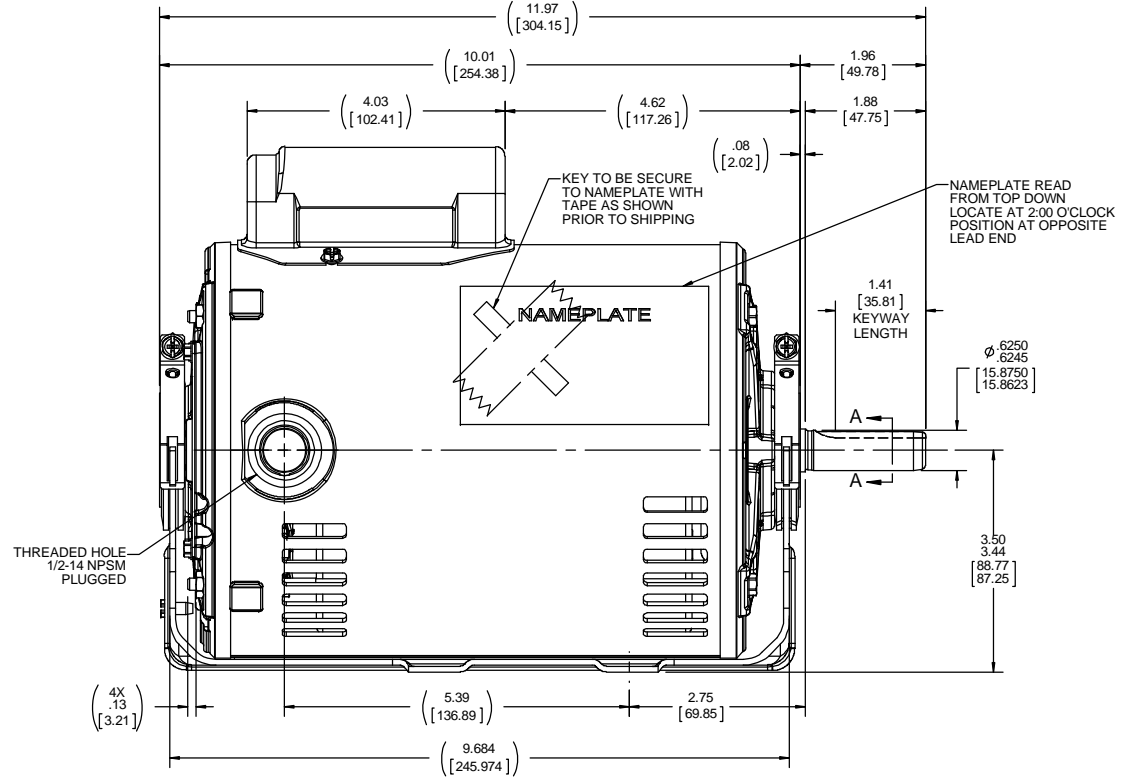
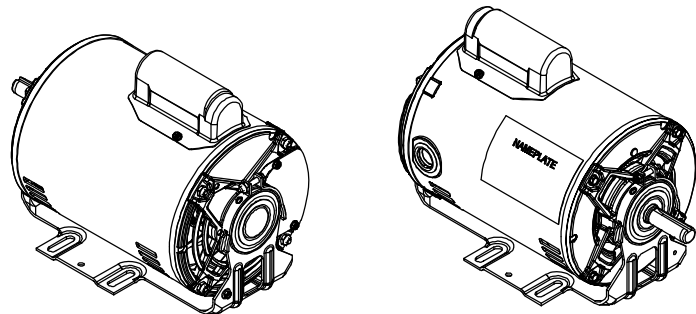

DRAWING REVISION A	REVISION BY	DATE	TOLERANCES UNLESS OTHERWISE SPECIFIED: DEC. INCH mm ANGLE .X ±0.1 [±2.5] 30.5° .XX ±0.03 [±0.76] .XXX ±0.005 [±0.127] .XXXX ±0.0005 [±0.0127] REMOVE BURRS & BREAK SHARP EDGES: .0031 [0.078] X 45° CORNER FILLETS: R.02 [.51] MACHINED SURFACES: .125 / 32 INCH/mil mm SHOWN IN [BRACKETS]	DRAWN BY D. SURYAWANSHI	Regal Beloit America, Inc.
ECO ECO-0148129	APPROVED BY	DATE	DATE 07/06/2018	DESCRIPTION OUTLINE 56FR,DP,1-PHASE,RESILIENT	
NEW DRAWING RELEASE			APPROVED BY PVR	DATE 07/06/2018	PROCESS/FINISH
<small>COPYRIGHT REGAL BELOIT AMERICA, INC. ALL RIGHTS RESERVED. PROPRIETARY AND CONFIDENTIAL INFORMATION. THIS DOCUMENT IS THE PROPERTY OF REGAL BELOIT AMERICA, INC. FORMER AND CONTAINS OWNERS PROPRIETARY INFORMATION. ANY PERSON, CORPORATION OR OTHER FIRM RECEIVING IT IS DEEMED BY RECEIVING IT, TO AGREE THAT IT, AND/OR ANY PART OF IT, SHALL NOT BE DISCLOSED TO ANY PERSON, CORPORATION OR OTHER ENTITY, DUPLICATED, AND/OR USED, EXCEPT AS EXPRESSLY APPROVED IN WRITING IN ADVANCE BY OWNER. THIS DOCUMENT SHALL BE RETURNED TO OWNER UPON REQUEST. IT MAY BE SUBJECT TO CERTAIN RESTRICTIONS UNDER APPLICABLE EXPORT CONTROL LAWS AND REGULATIONS.</small>			REFERENCE OLME173857	MATERIAL OLME173857	THIRD ANGLE PROJECTION
			SIZE C	DRAWING NUMBER OL56100498-001	SHEET 1 OF 1

