

# PRODUCT INFORMATION PACKET



Model No: D703  
Catalog No: D703

Fan and Blower Motor, 1/2-1/3-1/4 HP, 1 Ph, 60 Hz, 208-230 V, 1075 RPM, 3 Speed, 48 Frame, ODP



Regal and Fasco are trademarks of Regal Rexnord Corporation or one of its affiliated companies.  
©2022 Regal Rexnord Corporation, All Rights Reserved. MC017097E





**Nameplate Specifications**

Output HP	1/2-1/3-1/4 Hp	Output KW	0.37 kW
Frequency	60 Hz	Voltage	208-230 V
Current	4.0-2.7-2.0 A	Speed	1075 rpm
Service Factor	1	Phase	1
Duty	Continuous	Insulation Class	B
Frame	48	Enclosure	Open Drip Proof
Thermal Protection	Automatic	Ambient Temperature	40 °C
UL	Recognized	CSA	Y
CE	N	Number of Speeds	3

**Technical Specifications**

Electrical Type	Permanent Split Capacitor	Starting Method	Across The Line
Poles	6	Rotation	Reversible
Mounting	Extended Studs	Drive End Bearing	Sleeve
Opp Drive End Bearing	Sleeve	Frame Material	Rolled Steel
Shaft Type	Double Flat	Frame Length	5.16 in
Shaft Diameter	0.500 in	Shaft Extension	5.94 in
Outline Drawing	8857PVA-A12U		

This is an uncontrolled document once printed or downloaded and is subject to change without notice. Date Created:11/29/2022

### MOTOR SPECIFICATION

## 8857PVA-A12U

Q.R. No.	Y004436		CUSTOMER NO.	D703				
CUSTOMER	FASCO USA							
MOTOR RATING	VOLTS	208/230	Hz	60	Ph	1	Duty	S1 AOM
	RPM.	1075/3SP		4.0		AMPS		
	NOM. OUTPUT	537 WATTS (1/2 HP)						
ROTATION	REVERSIBLE							
CAPACITOR	START	-----	μF/V	RUN	7.5/---	μF/V		
ENCLOSURE	DRIPPROOF							
MOTOR TYPE	PSC	INSULATION CLASS	130 (B)					
THERMAL PROTECTION	AUTO RESET OVERLOAD							
APPLICATION	FAN AXIAL - SHAFT HORIZONTAL							
BEARING D.E.	SLEEVE		LUBRICATION	PERMAWICK OPERA.TEMP		-15° ~90° C		
BEARING N.D.E.	SLEEVE							
SUPPLY LEAD	AS SHOWN							
EARTH PROVISION	SUPPLIED							
BASIC BUILD SPECIFICATION	305-742-20	PAINT/ COLOUR	PC GREY PLAIN E/SHIELDS					
PERFORMANCE SPECIFICATION	SP88006-01	RATING LABEL	AS SHOWN					
CONNECTION DIAGRAM	AS SHOWN							

### FINAL INSPECTED MOTORS MUST COMPLY WITH ELECTRIC MOTOR VIBRATION SPECIFICATION (ES049)

THIRD ANGLE PROJECTION.

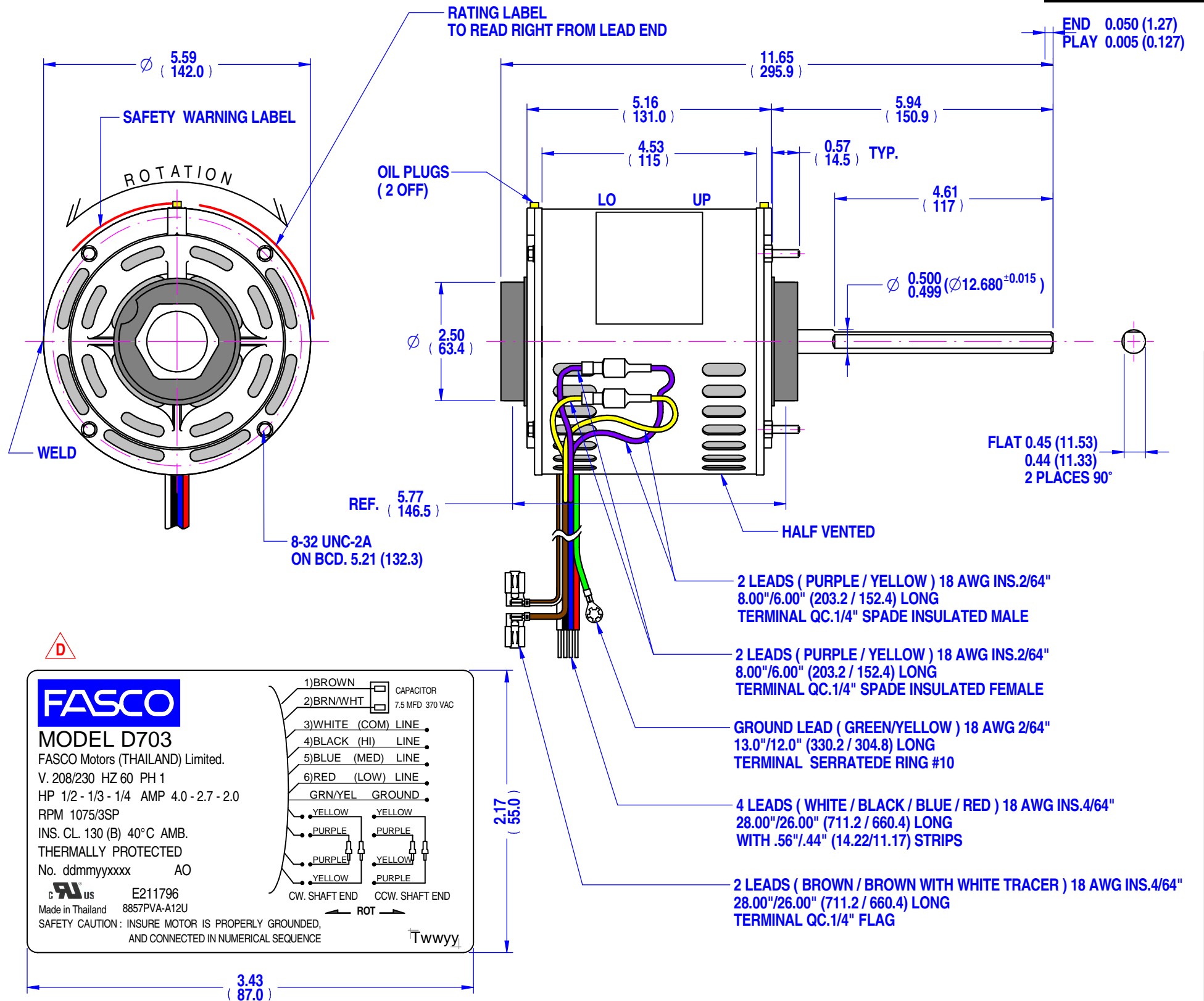

**FASCO**  
**MODEL D703**  
 FASCO Motors (THAILAND) Limited.  
 V. 208/230 HZ 60 PH 1  
 HP 1/2 - 1/3 - 1/4 AMP 4.0 - 2.7 - 2.0  
 RPM 1075/3SP  
 INS. CL. 130 (B) 40°C AMB.  
 THERMALLY PROTECTED  
 No. ddmmyyxxxx AO  
 E211796  
 Made in Thailand 8857PVA-A12U  
 SAFETY CAUTION: INSURE MOTOR IS PROPERLY GROUNDED,  
 AND CONNECTED IN NUMERICAL SEQUENCE

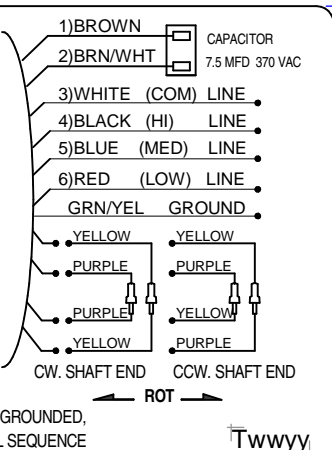

1) BROWN CAPACITOR  
 2) BRN/WHT 7.5 MFD 370 VAC  
 3) WHITE (COM) LINE  
 4) BLACK (HI) LINE  
 5) BLUE (MED) LINE  
 6) RED (LOW) LINE  
 GRN/YEL GROUND  
 CW. SHAFT END  
 CCW. SHAFT END  
 ROT

NOTE: DIMENSIONS SHOWN INCH (mm.)  
 STK - 50

**SAFETY WARNING**  
 THIS MOTOR MUST BE GROUNDED IN ACCORDANCE WITH LOCAL OR NATIONAL ELECTRICAL CODES TO PREVENT POSSIBLE INJURY DUE TO ELECTRICAL SHOCK  
 P071946



2.44 (62.0)  
 0.55 (14.0)

#### SPECIAL REQUIREMENTS:

- 1)\_CAPACITOR SUPPLIED BY CUSTOMER.
- 2)\_DO NOT PACK MOTOR IN PLASTIC BAG.
- 3)\_PUSH AND PULL SHAFT TO CENTRALIZE WASHER SLINGER.
- 4)\_STAMP FDC PART NUMBER FDC D703 ON THE BULK PACK.
- 5)\_ADD SAFETY BOOK P/N 398-063-02 IN ALL INDIVIDUAL CARTON.

#### UNLESS OTHERWISE SPECIFIED: DIMENSIONS ARE IN MM. TOLERANCES

DECIMALS	ANGULAR
.X ± 1.0	± 30'
.XX ± 0.1	

THIS DRAWING REMAINS THE PROPERTY OF FASCO MOTORS AND MAY NOT BE USED, COPIED OR ISSUED WITHOUT WRITTEN PERMISSION FROM FASCO MOTORS

MOTOR WEIGHT	7.6 kg.	
DRAWN	muntana	16/09/2011
CHECKED	Pipat	24/08/2017
RELEASED	Sutthipant	24/08/2017
SCALE	N.T.S.	

**FASCO THAILAND**  
 29/7-8 MOO 3, BANGKRUAY - SAINOI Rd.,  
 BANGKRANG, MUANG NONTABURI DISTRICT,  
 NONTABURI 11000 THAILAND

FRAME	MOTOR	
STATUS	R	
SHEET	B006:8857V-537-MCC:FDC	
A3	DWG. NO.	8857PVA-A12U
	REVISION	D