

PRODUCT INFORMATION PACKET



Model No: E100001.00

Catalog No: E100001.00

ecoSaver™ General Purpose Motor, 0.33 HP, 1 Ph, 60 Hz, 115/230 V, 1800 RPM, 56 Frame, DP



Regal and LEESON are trademarks of Regal Rexnord Corporation or one of its affiliated companies.

©2025 Regal Rexnord Corporation, All Rights Reserved. MC017097E





Nameplate Specifications

Phase	1	Output HP	0.33 Hp
Output KW	0.25 kW	Voltage	115/230 V
Speed	1725 rpm	Service Factor	1.35
Frame	56	Enclosure	Drip Proof
Thermal Protection	Automatic	Efficiency	72.4 %
Ambient Temperature	40 °C	Frequency	60 Hz
Current	3.8/1.9 A	Power Factor	79
Duty	Continuous	Insulation Class	F
Design Code	N	KVA Code	L
Drive End Bearing Size	6203	Opp Drive End Bearing Size	6203
UL	Recognized	CSA	Y
CE	Y	IP Code	22
Number of Speeds	1		

Technical Specifications

Electrical Type	Capacitor Start Capacitor Run	Starting Method	Across The Line
Poles	4	Rotation	Selective Counterclockwise
Resistance Main	0 Ohms	Mounting	Rigid Base
Motor Orientation	Horizontal	Drive End Bearing	Ball
Opp Drive End Bearing	Ball	Frame Material	Rolled Steel
Shaft Type	NEMA 56	Overall Length	10.99 in
Frame Length	7.00 in	Shaft Diameter	0.625 in
Shaft Extension	1.88 in	Assembly/Box Mounting	F1 ONLY
Connection Drawing	005053.40	Outline Drawing	SS404118-700

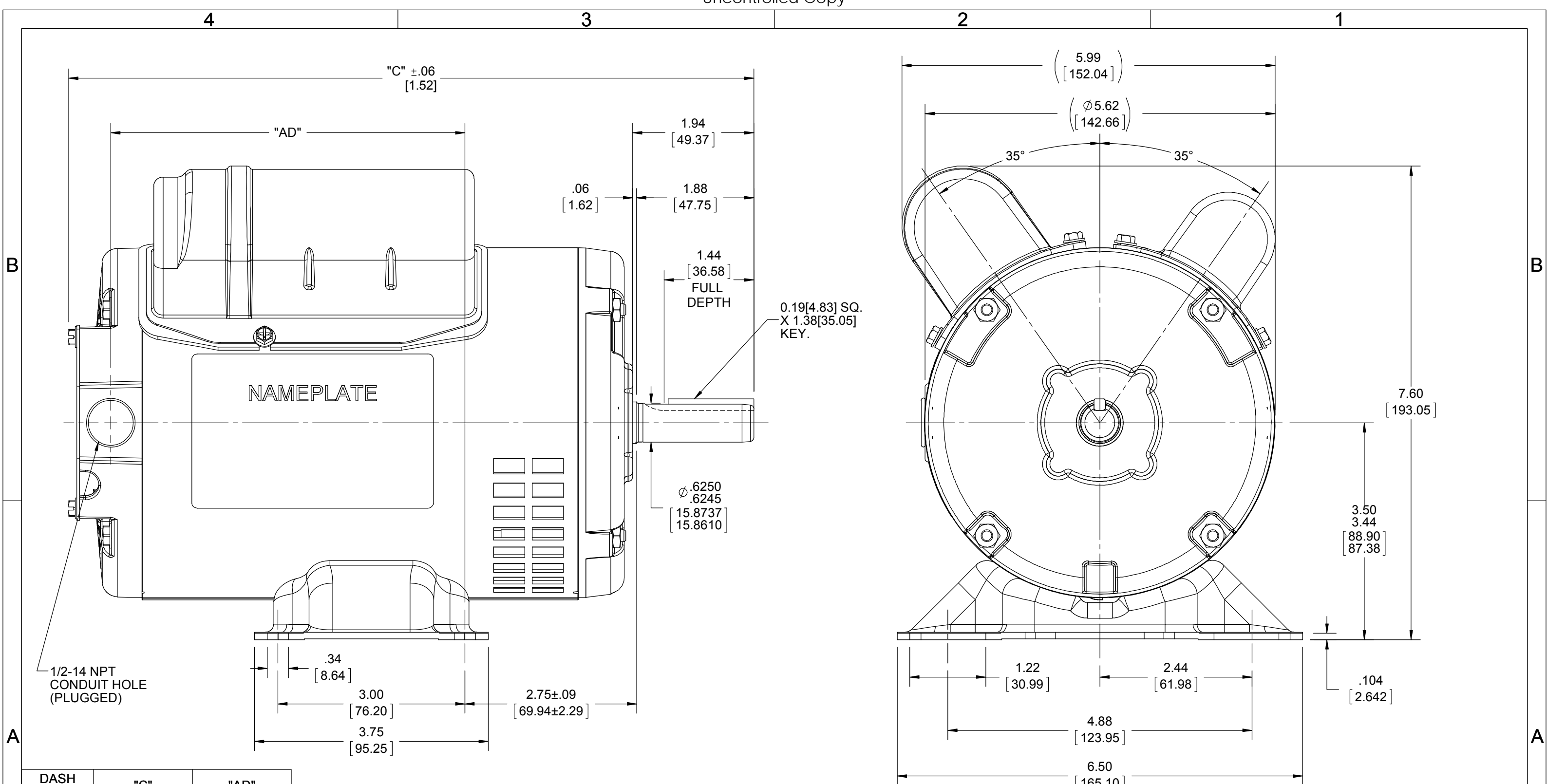

DASH NO.	"C"	"AD"
550	9.48[240.79]	4.18[106.17]
575	9.73[247.14]	4.43[112.52]
600	9.98[253.49]	4.68[118.87]
625	10.23[259.84]	4.93[125.22]
650	10.48[266.19]	5.18[131.57]
675	10.73[272.54]	5.43[137.92]
700	10.98[278.89]	5.68[144.27]
725	11.23[285.24]	5.93[150.62]
750	11.48[291.59]	6.18[156.97]
800	11.98[304.29]	6.68[169.67]

DRAWING REVISION F	REVISION BY S SAHOO	DATE 11/19/2018
ECO ECO-0160891	APPROVED BY S MACHARLA	DATE 01/29/2019
ECO DESCRIPTION OUTLINE CONVERSION PROJECT COPYRIGHT REGAL BELOIT AMERICA, INC. ALL RIGHTS RESERVED. PROPRIETARY AND CONFIDENTIAL INFORMATION - THIS DOCUMENT IS THE PROPERTY OF REGAL BELOIT AMERICA, INC. ("OWNER") AND CONTAINS OWNER'S PROPRIETARY INFORMATION. ANY PERSON, CORPORATION OR OTHER FIRM RECEIVING IT IS DEEMED, BY RECEIVING IT, TO AGREE THAT IT, AND/OR ANY PART OF IT, SHALL NOT BE DISCLOSED TO ANY PERSON, CORPORATION OR OTHER ENTITY, DUPLICATED, AND/OR USED, EXCEPT AS EXPRESSLY APPROVED IN WRITING IN ADVANCE BY OWNER. THIS DOCUMENT SHALL BE RETURNED TO OWNER UPON REQUEST. IT MAY BE SUBJECT TO CERTAIN RESTRICTIONS UNDER APPLICABLE EXPORT CONTROL LAWS AND REGULATIONS.		

TOLERANCES UNLESS OTHERWISE SPECIFIED:			
DEC.	INCH	mm	ANGLE
.X	±0.1	[±2.5]	±7° 30"
.XX	±0.03	[±0.76]	
.XXX	±0.005	[±0.127]	
.XXXX	±0.0005	[±0.0127]	
REMOVE BURRS & BREAK SHARP EDGES: .003/.015 [.076/.381] X 45° CORNER FILLETS: R.02 [.51] MACHINED SURFACES: 200 INCH/mm 5.1 mm SHOWN IN [BRACKETS]			

DRAWN BY PVR	DATE 11/28/14
APPROVED BY	DATE
REFERENCE 031619	THIRD ANGLE PROJECTION

REGAL ™ Regal Beloit America, Inc.	
DESCRIPTION OUTLINE S56 FRAME RIGID MOUNT-DRIP PROOF	
MATERIAL	PROCESS/FINISH
SIZE B	DRAWING NUMBER SS404118
SHEET 1 OF 1	

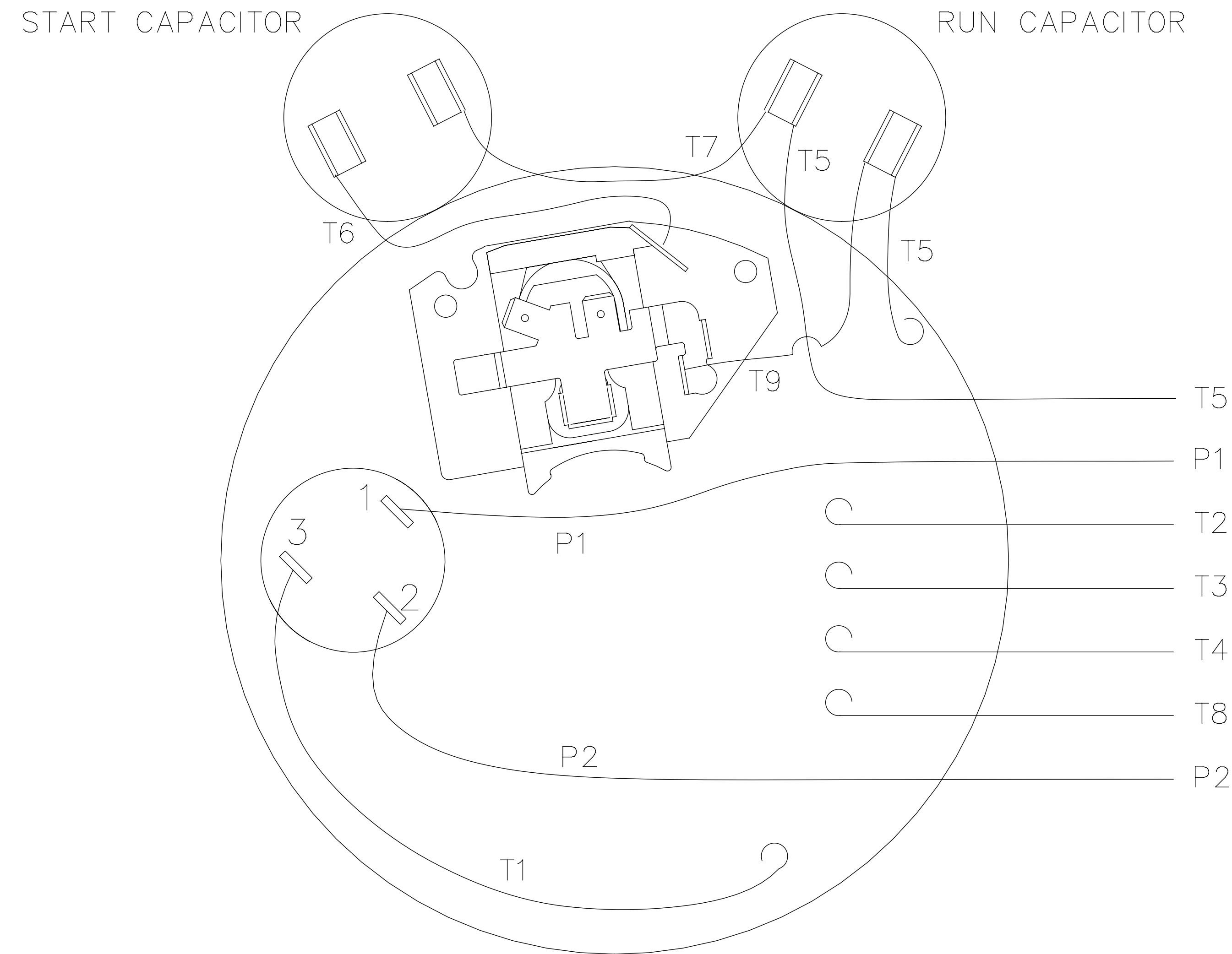

VIEW FROM OUTSIDE OF MOTOR AT SWITCH END

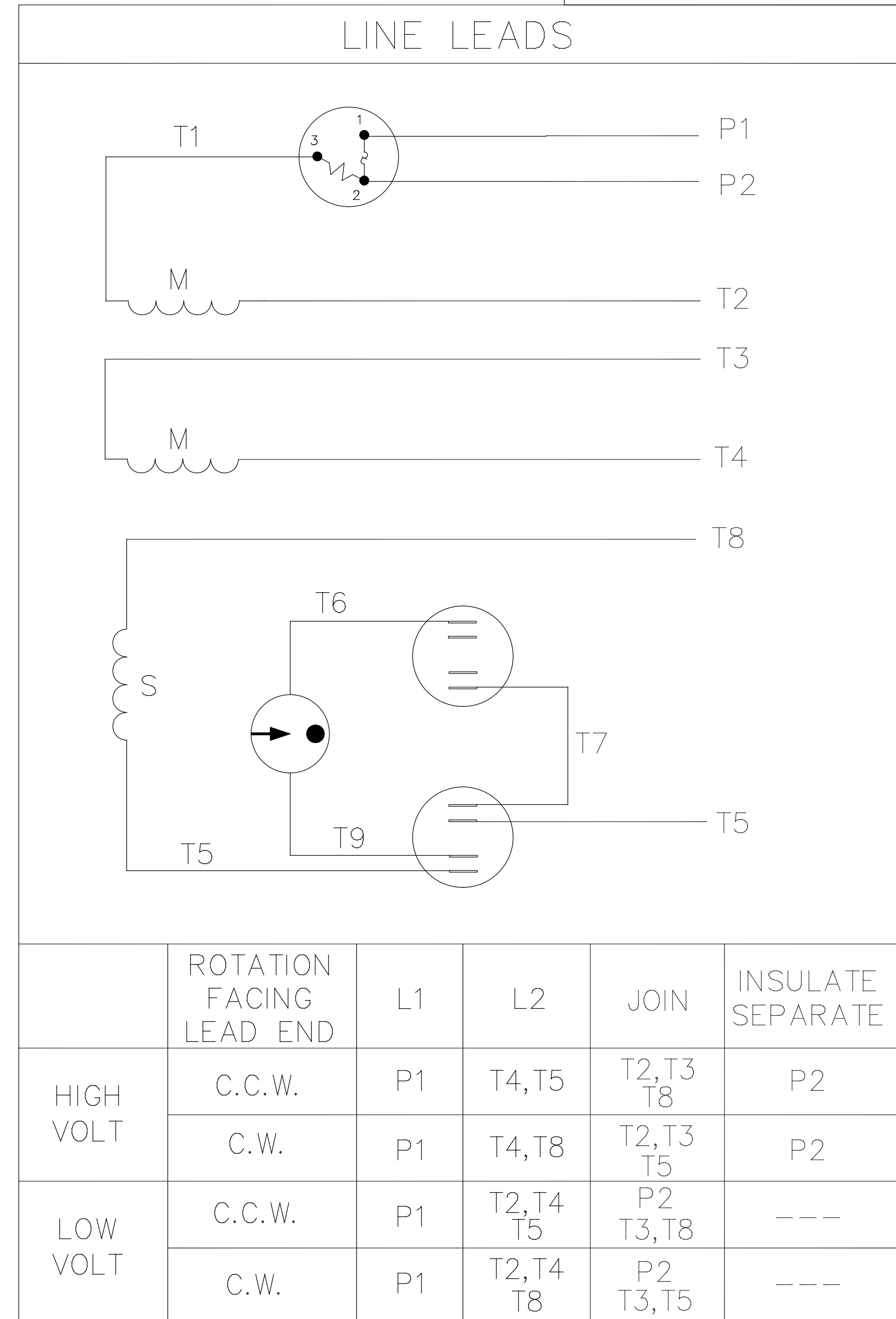

		TOLERANCES UNLESS SPECIFIED			
		DEC.	INCHES		
		.X	±.1		
		.XX	±.01		
		.XXX	±.005		
A	CHANGED LOGO TO REGAL	PST	2/1/16	SKM	.XXXX ±.0005
NO.	REVISION	BY & DATE	CHK	ANG	±1/2"
THIS DRAWING IN DESIGN AND DETAIL IS OUR PROPERTY AND MUST NOT BE USED EXCEPT IN CONNECTION WITH OUR WORK ALL RIGHTS OF DESIGN AND INVENTION ARE RESERVED THIS IS AN ELECTRONICALLY GENERATED DOCUMENT - DO NOT SCALE THIS PRINT		RFP		CAD FILE	00505340
		DIST		SIZE	A



TITLE EXTERNAL WIRING DIAGRAM
TYPE "K" W/PROTECTOR

MAT'L. DUAL VOLTAGE - DUAL ROTATION

DRAWN	PG 7/2/02
CHK	
APPD	
SCALE	5=8
REF	005053.01
FMF	102827.00
PREV	
DRAWING NO.	005053-40
REV.	A



CERTIFICATION DATA SHEET

**1051 CHEYENNE AVE.
GRAFTON, WI 53024
PH. 262-377-8810**

CONN. DIAGRAM: 005053.40

CATALOG #: E100001.00

OUTLINE: A-SS404118-700

MOUNTING: F1 ONLY

WINDING #: BE484111 3

TYPICAL MOTOR PERFORMANCE DATA

HP	kW	SYNC. RPM	F.L. RPM	FRAME	ENCLOSURE	KVA CODE	DESIGN
1/3	0.25	1800	1725	56	DP	L	N

PH	Hz	VOLTS	AMPS	START TYPE	DUTY	INSL	S.F.	AMB°C
1	60	115/230	3.8/1.9	ACROSS THE LINE	CONTINUOUS	F3	1.35	40

FULL LOAD EFF:	72.4	3/4 LOAD EFF:	61.2	1/2 LOAD EFF:	51.4	GTD. EFF		ELEC. TYPE	
FULL LOAD PF:	79	3/4 LOAD PF:	76.3	1/2 LOAD PF:	69.2	68		CAP START CAP RUN	

F.L. TORQUE	LOCKED ROTOR AMPS	L.R. TORQUE	B.D. TORQUE	F.L. RISE°C
16 OZ-FT	28.4 / 14.2	58 OZ-FT 362 %	43.5 OZ-FT 272 %	30

SOUND PRESSURE @ 3 FT.	SOUND POWER	ROTOR WK^2	MAX. WK^2	SAFE STALL TIME	STARTS / HOUR	APPROX. MOTOR WGT
0 dBA	10 dBA	0 LB-FT^2	0 LB-FT^2	10 SEC.	0	16 LBS.

***** SUPPLEMENTAL INFORMATION *****

DE BRACKET TYPE	ODE BRACKET TYPE	MOUNT TYPE	ORIENTATION	SEVERE DUTY	HAZARDOUS LOCATION	DRIP COVER	SCREENS	PAINT
STANDARD	NONE	RIGID	HORIZONTAL	FALSE	NONE	FALSE	NONE	GREEN - LEESON WATTSAVER

BEARINGS		GREASE	SHAFT TYPE	SPECIAL DE	SPECIAL ODE	SHAFT MATERIAL	FRAME MATERIAL
DE	ODE						
BALL	BALL	POLYREX EM	STANDARD 56	NONE	NONE	1144 STRESSPROOF (C-223)	ROLLED STEEL
6203	6203						

THERMO-PROTECTORS				THERMISTORS	CONTROL	SPACE HEATERS
THERMOSTATS	PROTECTORS	WDG RTDs	BRG RTDs			
NONE	AUTOMATIC	NONE	NONE	NONE	FALSE	NONE VOLTS

*
N
O
T
E
S

INVERTER TORQUE: NONE
INV. HP SPEED RANGE: NONE
ENCODER: NONE
NONE NONE
NONE NONE PPR
BRAKE: NONE NONE
NONE P/N NONE
NONE NONE
NONE FT-LB NONE V NONE HZ



LEESON ELECTRIC CORPORATION
 TYPICAL PERFORMANCE CURVE for AC MOTOR

Model No E100001.00

Curve at 230 Volts HP 0.33 PHASE 1
60 HZ
0.33 HP VOLTS 115/230

Catalog No E100001.00

HZ 60 RPM 1725

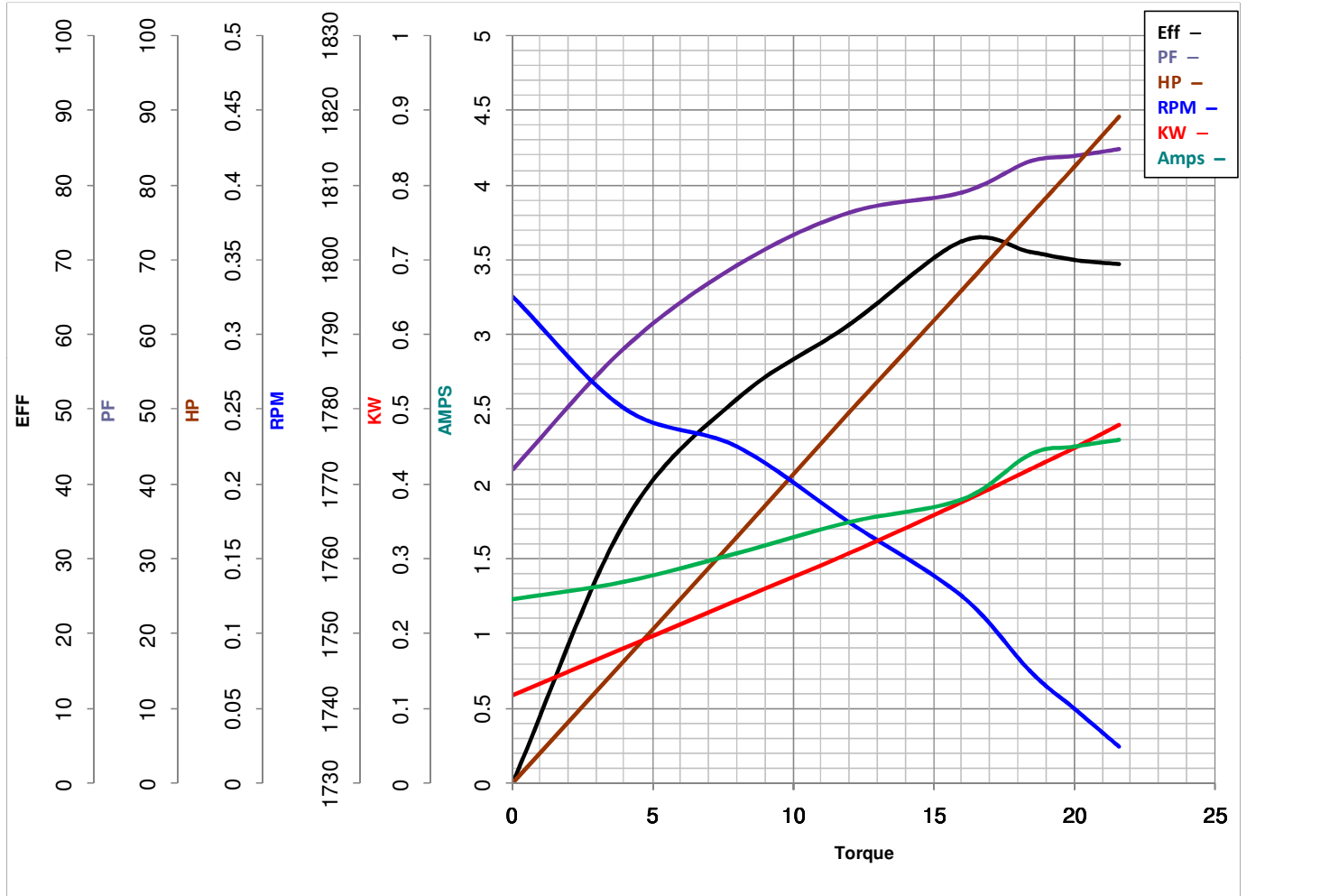

Torque in Oz.Ft

FL TORQUE 16 Oz.Ft
 BD TORQUE 43.5 Oz.Ft
 LR TORQUE 58 Oz.Ft

FL AMPS 3.8/1.9
 PU TORQUE 58.0 Oz.Ft
 LR AMPS 14.2

WINDING BE484111-3

Date 4/19/2018

EC Declaration of Conformity

The undersigned representing
the manufacturer:

Regal Beloit America
1946 West Cook Road
Fort Wayne, IN 46818

and the authorized representative
established within the Community:

Regal Beloit Italy
Via Modena, 18
24040 Ciserano(BG) - Italy

are committed to providing customers with products that comply with applicable regulations and international protocols to which they are subject, including the requirements of the European Parliament Directive on the Harmonization of the laws relating to electrical equipment designed for use within certain voltage limits (2014/35/EU).

Regal Beloit America declares that the following product(s), to which this declaration relates, are in conformity with the relevant sections of the EC standards listed below.

This statement supersedes any statements previously issued pertaining to the product(s) listed below and is subject to change without notice.

Model No : E100001.00

(Model No. may contain prefix and/or suffix characters)

Catalog No : E100001.00

Rework No : N/A

Directives :

Low Voltage Directive 2014/35/EU

Harmonized Standards Used :

EN 60034-1: 2010 (IEC 60034-1: 2010)

EN 60034-5: 2001/A1:2007 (IEC 60034-5: 2000/A1:2006)

Authorized Representative:



Zach Stauffer
Vice President, Engineering

Authorized Representative in the Community:



Stefano Casiraghi
Technology Director, Engineering

Created on 07/28/2025

CE 25