

# PRODUCT INFORMATION PACKET



Model No: FE6002F  
Catalog No: FE6002F

MASTERFIT PRO® Condenser Fan Motor, 1/2,1/4 HP, 1 Ph, 60 Hz, 208-230 V, 1075 RPM, 2 Speed, 48 Frame, TEAO



Regal and Century are trademarks of Regal Rexnord Corporation or one of its affiliated companies.  
©2023 Regal Rexnord Corporation, All Rights Reserved. MC017097E





**Nameplate Specifications**

Output HP	1/2,1/4 Hp	Output KW	0.37 kW
Frequency	60 Hz	Voltage	208-230 V
Current	3.2,1.6 A	Speed	1075 rpm
Service Factor	1	Phase	1
Duty	Air Over	Insulation Class	F
Frame	48	Enclosure	Totally Enclosed Air Over
Thermal Protection	Automatic	Ambient Temperature	70 °C
UL	Recognized	CSA	Y
CE	N	Number of Speeds	2

**Technical Specifications**

Electrical Type	Permanent Split Capacitor	Starting Method	Across The Line
Poles	6	Rotation	Reversible
Mounting	Extended Studs	Motor Orientation	Any
Drive End Bearing	Ball	Opp Drive End Bearing	Ball
Frame Material	Rolled Steel	Shaft Type	Double Flat
Overall Length	12.74 in	Frame Length	4.75 in
Shaft Diameter	0.500 in	Shaft Extension	6.5 in
Outline Drawing	FE6002F_FA	Connection Drawing	614131-308

This is an uncontrolled document once printed or downloaded and is subject to change without notice. Date Created:02/16/2023

GENERAL INFORMATION:

SHAFT RUNOUT: .001[.03] T.I.R. PER INCH LENGTH OF EXTENSION

BEARINGS: BALL

MOUNTING POSITION: ALL ANGLE

ELECTRICAL DATA:

OVERLOAD PROTECTOR: AUTOMATIC RESET (SENSATA 7AM 304)

LINE LEADS: NO. 18 GA., .06[1.5] THK. XLP 125°C INSUL.

REVERSING PLUGS: NO. 18 GA., .03[.8] THK. XLP 125°C INSUL.

GROUND LEAD: NO. 18 GA., .03[.8] THK. (GREEN) INSUL.

CAPACITOR: 10 MFD/370 VAC @ 230 VOLT  
12.5 MFD/370 VAC @ 208 VOLT

SAMPLE SM19-468  
NAMEPLATE DATA:

MODEL NO.: 5KCP39NGDD684S  
CUST. P/N: FE6002F  
HP: 1/2,1/4  
ROT.: REVERSIBLE  
RPM: 1075/2 SPD  
TYPE: UF  
FRAME: 48Y  
VOLTS: 208-230  
PH: 1  
AMPS: 3.2,1.6  
HZ: 60  
INS.: F  
AMB.: 70°C  
DUTY: AIR OVER  
CAP.: 12.5 OR 10 MFD/370V  
THERMALLY PROTECTED

**REGAL**  
E27885  
MADE IN INDIA

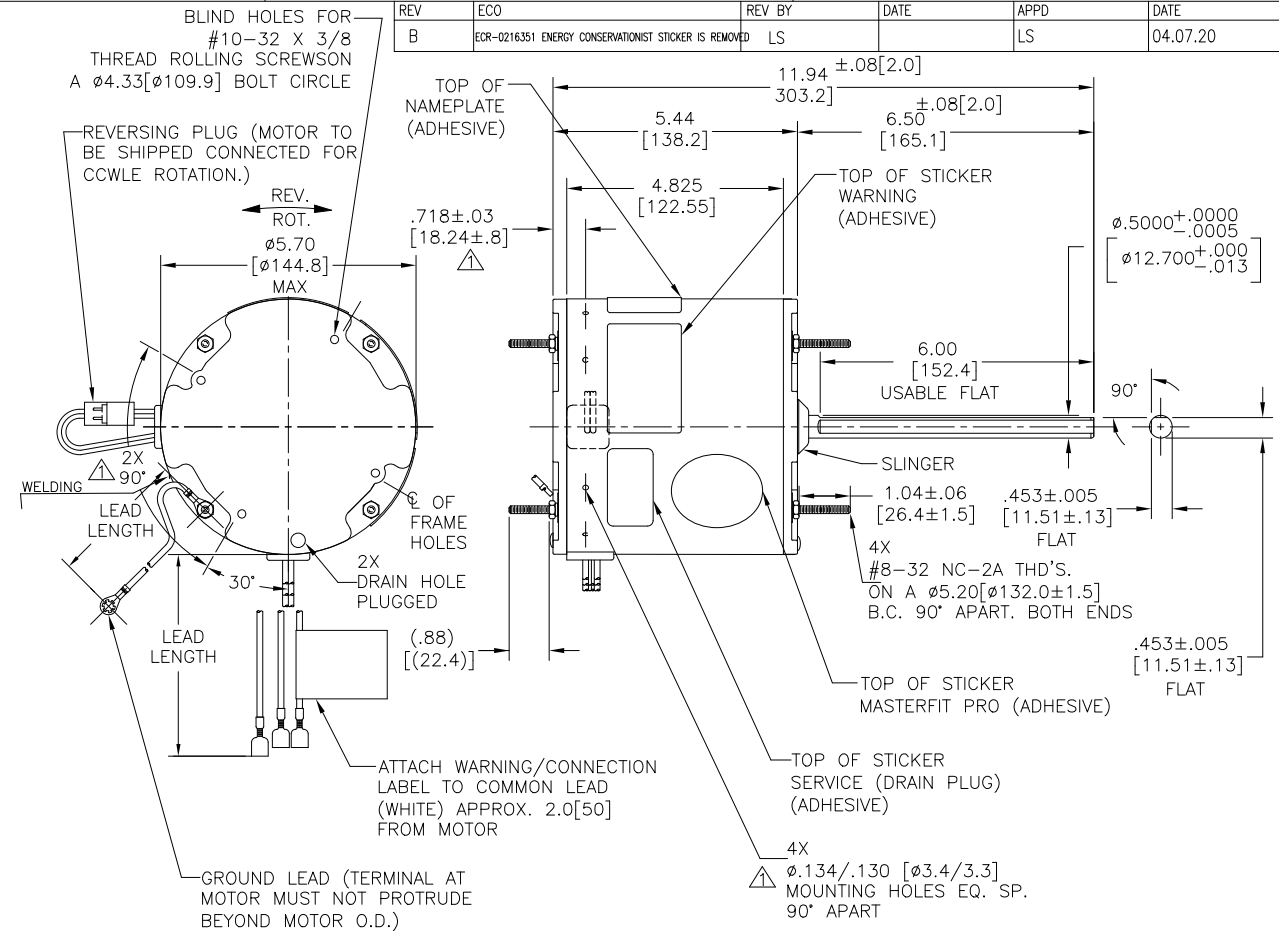
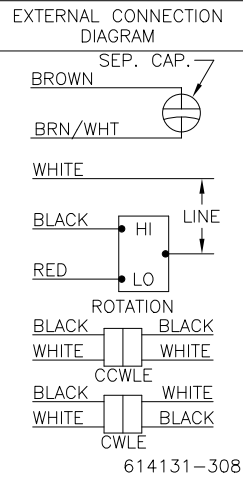

GREEN (GROUND)	12.0/13.0 [305/330]	#10 EYELET
BLACK/WHITE	4.0/6.0 [100/152]	REVERSING PLUG
BROWN	48.0/51.0 [1219/1295]	.25[6.4] FEMALE
BROWN/WHITE	48.0/51.0 [1219/1295]	.25[6.4] FEMALE
RED	48.0/51.0 [1219/1295]	.50[12.7] FEMALE
BLACK	48.0/51.0 [1219/1295]	.50[12.7] FEMALE
WHITE	48.0/51.0 [1219/1295]	.50[12.7] FEMALE
COLOR	LENGTH	TERMINAL OR STRIP LENGTH

- NOTES:
- △ DENOTES CRITICAL CHARACTERISTICS.
  - 2. 4 #8 SCREWS AND 4 NUTS AND 4 #10 SCREW AND (1) 2518746-001 CLAMP AND (1) CAPACITOR TO BE PUT IN A POLYBAG & BE PACKED WITH EACH MOTOR.
  - 3. ALL LABEL READ FROM LE
  - 4. SPRING SHIM IN OLE SIDE

MAIN FRAME - OLE	ENCLOSED
END FRAME - OLE	ENCLOSED
MAIN FRAME - LE	ENCLOSED
END FRAME - LE	ENCLOSED
ENCLOSURE	

CUSTOMER	DISTRIBUTION SERVICE
----------	----------------------

GEOMETRIC CHARACTERISTICS & SYMBOLS

- FLATNESS
- STRAIGHTNESS
- ∠ ANGULARITY
- ⊥ PERPENDICULARITY (SQUARENESS)
- ∥ PARALLELISM
- ROUNDNESS (CIRCULARITY)
- ⊘ CYLINDRICITY
- ⊖ PROFILE OF ANY SURFACE
- ⊖ PROFILE OF ANY LINE
- ⊖ RUNOUT
- ⊖ TRUE POSITION
- ⊖ CONCENTRICITY
- ⊖ SYMMETRY

ASME Y14.5M 1994

REGAL-BELOIT CORPORATION (RBC) PROVIDES TECHNICAL ASSISTANCE TO OUR CUSTOMERS IN SEVERAL AREAS. SINCE RBC DOES NOT RECEIVE ALL DATA CONCERNING THE USE AND APPLICATION OF THE MOTOR, THE SUITABILITY OF THE MOTOR FOR THE APPLICATION MUST BE DETERMINED BY THE CUSTOMER.

DIMENSIONS WITHOUT TOLERANCES ARE FOR REFERENCE ONLY.

DR BY: MK 13.11.19  
 APPD: LS 13.11.19  
 THIRD ANGLE PROJECTION  
 CONFIDENTIAL: THIS DRAWING AND ITS INFORMATION ARE THE EXCLUSIVE AND CONFIDENTIAL PROPERTY OF REGAL-BELOIT CORPORATION AND ARE NOT TO BE DISCLOSED, DUPLICATED, DISTRIBUTED OR OTHERWISE USED WITHOUT THE WRITTEN CONSENT OF REGAL-BELOIT CORPORATION. -ALL RIGHTS RESERVED.

**REGAL REGAL-BELOIT CORPORATION**

DESCRIPTION: MODEL-RFHP-48FR OUTLINE

SIZE: C DWG NO: FE6002F\_FA

SCALE: NONE SHEET: 1

REV	ECO	REV BY	DATE	APPD	DATE
B	ECO-0021670	jrupert	07-22-2011	jrupert	07-22-2011

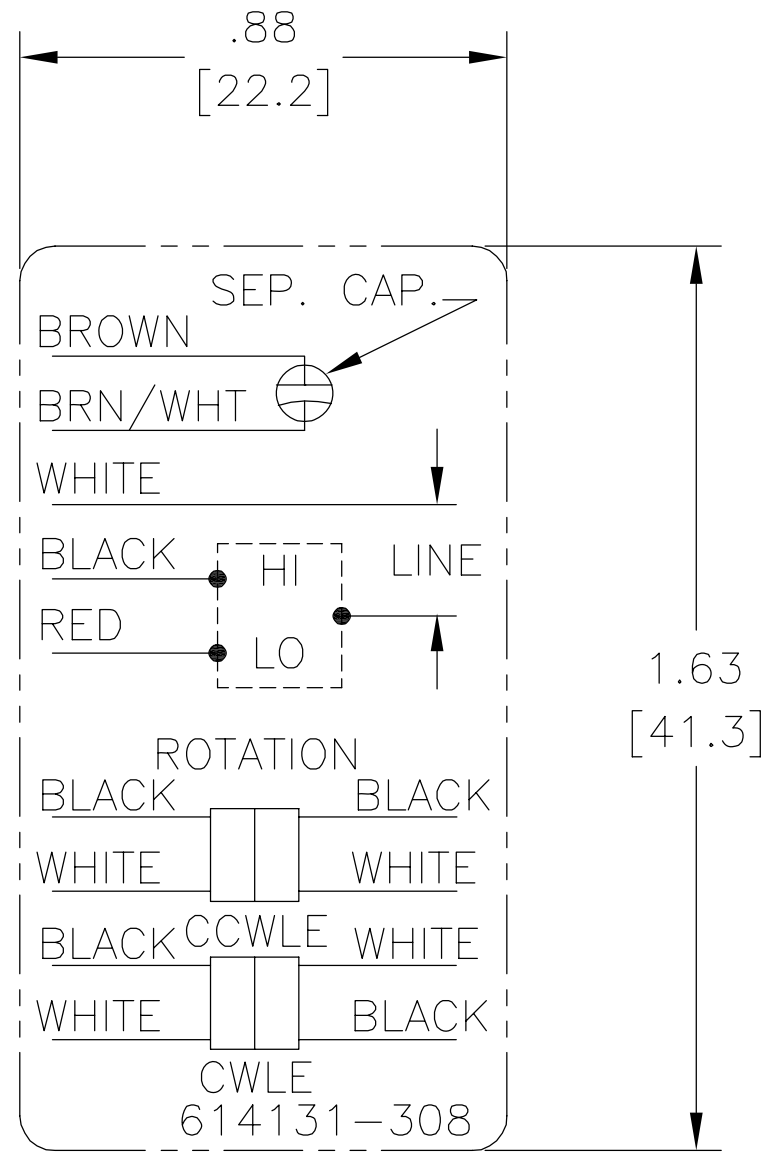

NOTES:

1. FOR USE WITH 614129 NAMEPLATE BLANK
2. — — — — — INDICATES DIMENSION LIMITS
3. DIE TO BE MADE FROM MASTER SUPPLIED BY A. O. SMITH CORPORATION
4. DIE MUST PRODUCE A LEGIBLE IMPRESSION.

GEOMETRIC CHARACTERISTICS & SYMBOLS ▭ FLATNESS — STRAIGHTNESS ∠ ANGULARITY ⊥ PERPENDICULARITY (SQUARENESS) // PARALLELISM ○ ROUNDNESS (CIRCULARITY) ⊘ CYLINDRICITY △ PROFILE OF ANY SURFACE ∩ PROFILE OF ANY LINE ↑ RUNOUT ⊕ TRUE POSITION ◎ CONCENTRICITY = SYMMETRY	UNLESS OTHERWISE SPECIFIED DIM. TOLERANCES ARE AS FOLLOWS: INCH X XX XXX XXXX mm ±0.5 ±0.13 ±0.013 ANG. ±.50 DEG REMOVE BURRS & BREAK SHARP EDGES: INCH .003-.015 mm 0.1-0.4 CORNER FILLETS TO: INCH .020 mm 0.5 MACHINE SURFACES: INCH 125 mm 3.2 METRIC DIMS. SHOWN IN [BRACKETS]	DR BY:	jrupert	07-22-2011	<b>ELECTRICAL PRODUCTS COMPANY</b> A DIVISION OF A. O. SMITH CORPORATION				
		APPD:	jrupert	07-22-2011		DESCRIPTION	CONN DIAGRAM NAMEPLATE		
		THIRD ANGLE PROJECTION	EDS DATE 02-22-2008 FORMAT REV F	CONFIDENTIAL: THIS DRAWING AND ITS INFORMATION ARE THE EXCLUSIVE AND CONFIDENTIAL PROPERTY OF A.O. SMITH CORP. AND ARE NOT TO BE DISCLOSED, DUPLICATED, DISTRIBUTED OR OTHERWISE USED WITHOUT THE WRITTEN CONSENT OF A.O. SMITH CORP. -ALL RIGHTS RESERVED. ASME Y14.5M 1994		SIZE	A	DWG NO	614131-308
				SCALE	NONE	SHEET	1		

REVISION:	ECO	REVISADO POR:	FECHA:	APROBADO POR:	FECHA:
B	ECO-0021670	jrupert	07-22-2011	jrupert	07-22-2011

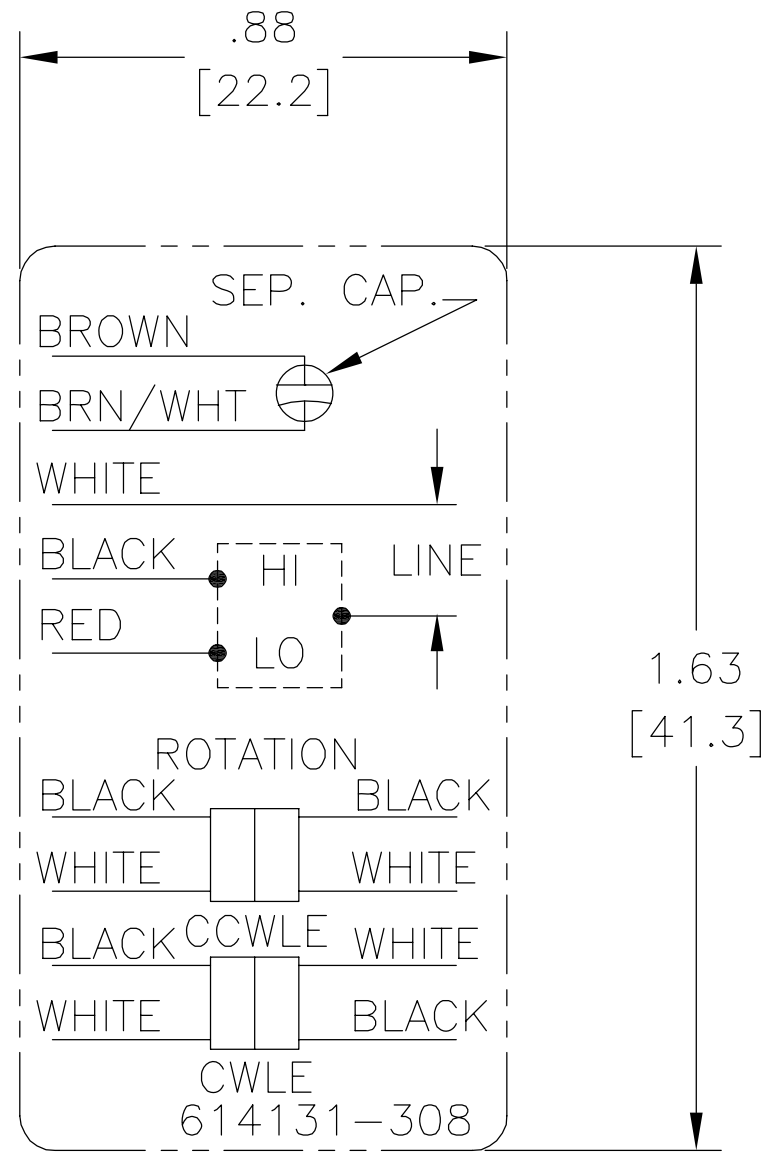

NOTES:

1. FOR USE WITH 614129 NAMEPLATE BLANK
2. ——— ———— INDICATES DIMENSION LIMITS
3. DIE TO BE MADE FROM MASTER SUPPLIED BY A. O. SMITH CORPORATION
4. DIE MUST PRODUCE A LEGIBLE IMPRESSION.

CARACTERISTICAS DE GEOMETRIA Y SIMBOLOS ▯ PLANICIDAD — RECTITUD < ANGULARIDAD ⊥ PERPENDICULARIDAD (A ESCUADRA) // PARALELISMO ○ REDONDEZ (CIRCULARIDAD) ∅ CILINDRICIDAD △ PERFIL DE CUALQUIER SUPERFICIE ∩ PERFIL DE CUALQUIER LINEA ↑ VARIACION ⊕ POSICION REAL ⊙ CONCENTRICIDAD = SIMETRIA
---

A MENOS QUE SE ESPECIFIQUE DE OTRA MANERA, LAS TOLERANCIAS DE LAS DIMS; SON LAS SIGUIENTES: X XX XXX XXXX PULG ±.1 ±.02 ±.005 ±.0005 mm ±0.5 ±0.13 ±0.013 ANG. ±.50 GRADOS ELIMINAR REBABAS Y ORILLAS FILOSAS DEL BORDE. PULG .003-.015 mm 0.1-0.4 FILETEAR ESQUINA: PULG .020 mm 0.5 MAQUINAR SUPERFICIES PULG 125 mm 3.2 DIMS METRICAS MOSTRADAS [PARENTESIS]
---

DIBUJADO POR:	jrupert	07-22-2011
APROBADO POR:	jrupert	07-22-2011
TERCER ANGULO DE PROYECCION		FECHA EDS: 02-22-2008 REV. FORMATO: F
CONFIDENCIAL: ESTE DIBUJO Y SU INFORMACION SON PROPIEDAD DE USO EXCLUSIVO Y CONFIDENCIAL DE A.O.SMITH CORP. Y NO DEBERAN SER REVELADOS, DUPLICADOS, DISTRIBUIDOS O USARSE DE OTRA MANERA SIN EL CONSENTIMIENTO ESCRITO DE A.O. SMITH CORP. -TODOS LOS DERECHOS RESERVADOS.ASME Y14.5M 1994		

<b>ELECTRICAL PRODUCTS COMPANY</b> A DIVISION OF A. O. SMITH CORPORATION		
DESCRIPCION:		CONN DIAGRAM NAMEPLATE
TAMAÑO: A	NUMERO DE DIBUJO: 614131-308	
ESCALA: NONE		HOJA: 1

版本	ECO	编制	日期	批准	日期
B	ECO-0021670	jrupert	07-22-2011	jrupert	07-22-2011

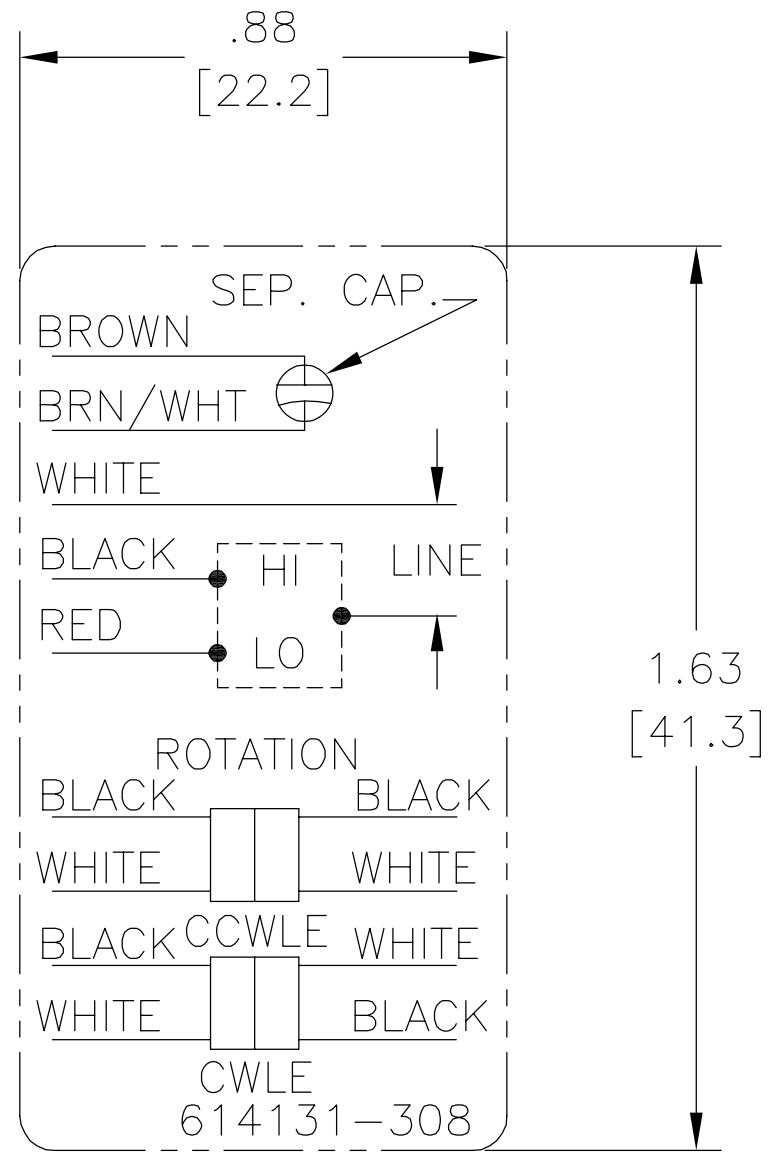

NOTES:

1. FOR USE WITH 614129 NAMEPLATE BLANK
2. ———— INDICATES DIMENSION LIMITS
3. DIE TO BE MADE FROM MASTER SUPPLIED BY A. O. SMITH CORPORATION
4. DIE MUST PRODUCE A LEGIBLE IMPRESSION.

形位公差 □ 平面度 — 直线度 ∠ 倾斜度 ⊥ 垂直度 // 平行度 ○ 圆度 ⊙ 圆柱度 △ 面轮廓度 ∩ 线轮廓度 ↗ 圆跳动 ⊕ 位置度 ◎ 同轴度 ≡ 对称度	除另有注明 尺寸公差如下: 英寸 X XX XXX XXXX ±.1 ±.02 ±.005 ±.0005 毫米 ±0.5 ±0.13 ±0.013 角度 ±.50 度 清理毛刺和尖棱 英寸 .003-.015 毫米 0.1-0.4 内圆角 英寸 .020 毫米 0.5 表面粗糙度 英制 125 米制 3.2 米制尺寸显示在 [ ]
---	--

绘图:	jrupert	07-22-2011
批准:	jrupert	07-22-2011
第三角投影		图纸格式发布日期 02-22-2008 图纸格式版本 F
机密: 本图纸及相关信息所有权归A. O. SMITH公司所有。 未经A. O. SMITH公司书面授权, 不得泄露、复制、传播或作 其他用途。—版权所有		
ASME Y14.5M 1994		

		<b>ELECTRICAL PRODUCTS COMPANY</b> <small>A DIVISION OF A. O. SMITH CORPORATION</small>	
名称 CONN DIAGRAM NAMEPLATE			
图幅	A	图号	614131-308
比例	NONE	页号	1