

PRODUCT INFORMATION PACKET



Model No: GF2024
Catalog No: GF2024
Fan and Blower Motor, 1/4 HP, 1 Ph, 60 Hz, 115 V, 1800 RPM, 48 Frame, ODP



Regal and Century are trademarks of Regal Rexnord Corporation or one of its affiliated companies.
©2023 Regal Rexnord Corporation, All Rights Reserved. MC017097E





Nameplate Specifications

Phase	1	Output HP	1/4 Hp
Output KW	0.19 kW	Voltage	115 V
Speed	1725 rpm	Service Factor	1.35
Frame	48	Enclosure	Open Drip Proof
Thermal Protection	Automatic	Ambient Temperature	40 °C
Frequency	60 Hz	Current	5.0 A
Duty	Continuous	Insulation Class	B
UL	No	CSA	Y
CE	N	Number of Speeds	1

Technical Specifications

Electrical Type	Split Phase	Starting Method	Across The Line
Poles	4	Rotation	Reversible
Mounting	Resilient Base	Drive End Bearing	Sleeve
Opp Drive End Bearing	Sleeve	Frame Material	Rolled Steel
Shaft Type	Flat	Overall Length	8.90 in
Frame Length	4.69 in	Shaft Diameter	0.625 in
Shaft Extension	1.5 in		
Connection Drawing	621417-001A	Outline Drawing	GF2024-S01

This is an uncontrolled document once printed or downloaded and is subject to change without notice. Date Created:08/24/2023

CATALOG NUMBER	UL NUMBER	FRAME
GF2024	E46412	48

REV	ECO	REV BY	DATE	APPD	DATE
A	ECO-0031789	J. COX	04-03-2013	C. McREYNOLDS	04-03-2013

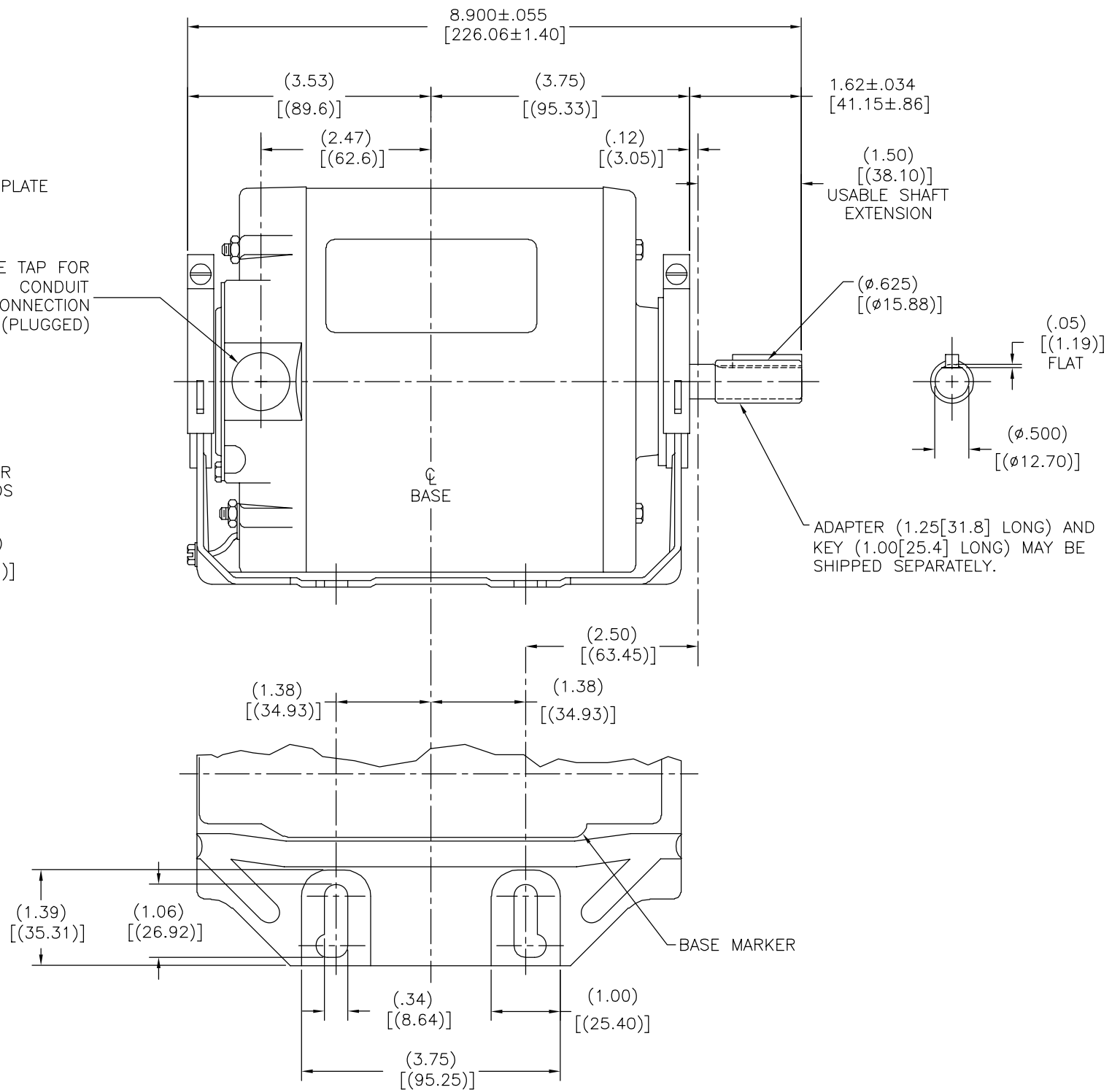
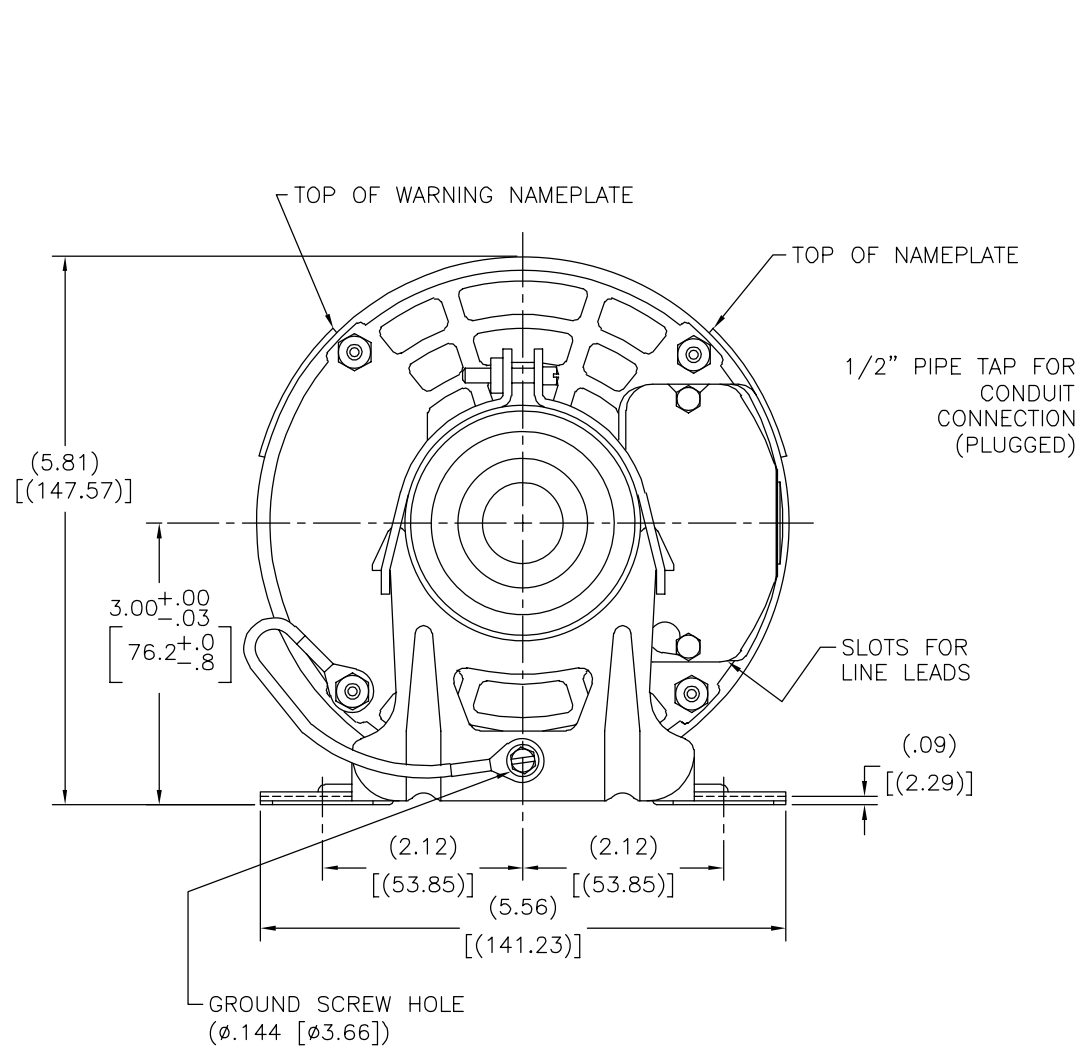

GEOMETRIC CHARACTERISTICS & SYMBOLS

- ▧ FLATNESS
- STRAIGHTNESS
- ∠ ANGULARITY
- ⊥ PERPENDICULARITY (SQUARENESS)
- ∥ PARALLELISM
- ROUNDNESS (CIRCULARITY)
- ⊘ CYLINDRICITY
- △ PROFILE OF ANY SURFACE
- ∩ PROFILE OF ANY LINE
- ↯ RUNOUT
- ⊕ TRUE POSITION
- ◎ CONCENTRICITY
- ≡ SYMMETRY

ASME Y14.5M 1994

UNLESS OTHERWISE SPECIFIED DIM. TOLERANCES ARE AS FOLLOWS:

INCH	±.1	±.02	±.005	±.0005
mm	±0.5	±0.13	±0.013	

ANG. ±.50 DEG
REMOVE BURRS & BREAK SHARP EDGES:
INCH .003-.015 mm 0.1-0.4
CORNER FILLETS TO:
INCH .020 mm 0.5
MACHINE SURFACES:
INCH 125 mm 3.2

METRIC DIMS. SHOWN IN [BRACKETS]

DR BY:	J. COX	04-03-2013
APPD:	C. McREYNOLDS	04-03-2013
THIRD ANGLE PROJECTION		EDS DATE 11-11-2011 FORMAT REV H
CONFIDENTIAL: THIS DRAWING AND ITS INFORMATION ARE THE EXCLUSIVE AND CONFIDENTIAL PROPERTY OF REGAL-BELOIT CORPORATION AND ARE NOT TO BE DISCLOSED, DUPLICATED, DISTRIBUTED OR OTHERWISE USED WITHOUT THE WRITTEN CONSENT OF REGAL-BELOIT CORPORATION. -ALL RIGHTS RESERVED.		

REGAL-BELOIT CORPORATION	
DESCRIPTION MODEL-RFHP-48FR OUTLINE	
SIZE C	DWG NO GF2024
SCALE NONE	SHEET 1