

PRODUCT INFORMATION PACKET



Model No: H524LES
Catalog No: H524LES

General Purpose Motor, 1 HP, 3 Ph, 60 Hz, 230/460 V, 1800 RPM, 56 Frame, TEFC



Regal and Century are trademarks of Regal Rexnord Corporation or one of its affiliated companies.
©2022 Regal Rexnord Corporation, All Rights Reserved. MC017097E





Nameplate Specifications

Output HP	1 Hp	Output KW	0.75 kW
Frequency	60 Hz	Voltage	230/460 V
Current	3.3/1.65 A	Speed	1725 rpm
Service Factor	1.15	Phase	3
Efficiency	85.5 %	Duty	Continuous
Insulation Class	B	Frame	56
Enclosure	Totally Enclosed Fan Cooled	Thermal Protection	No Protection
Ambient Temperature	40 °C	UL	Recognized
CSA	Y	CE	Y
Number of Speeds	1		

Technical Specifications

Electrical Type	Three Phase	Starting Method	Across The Line
Poles	4	Rotation	Reversible
Mounting	Rigid Base	Drive End Bearing	Ball
Opp Drive End Bearing	Ball	Frame Material	Rolled Steel
Shaft Type	NEMA 56	Overall Length	14.33 in
Frame Length	8.75 in	Shaft Diameter	0.625 in
Shaft Extension	2.03 in		
Connection Drawing	DD10038-001	Outline Drawing	OL56100051-001

This is an uncontrolled document once printed or downloaded and is subject to change without notice. Date Created:12/27/2022

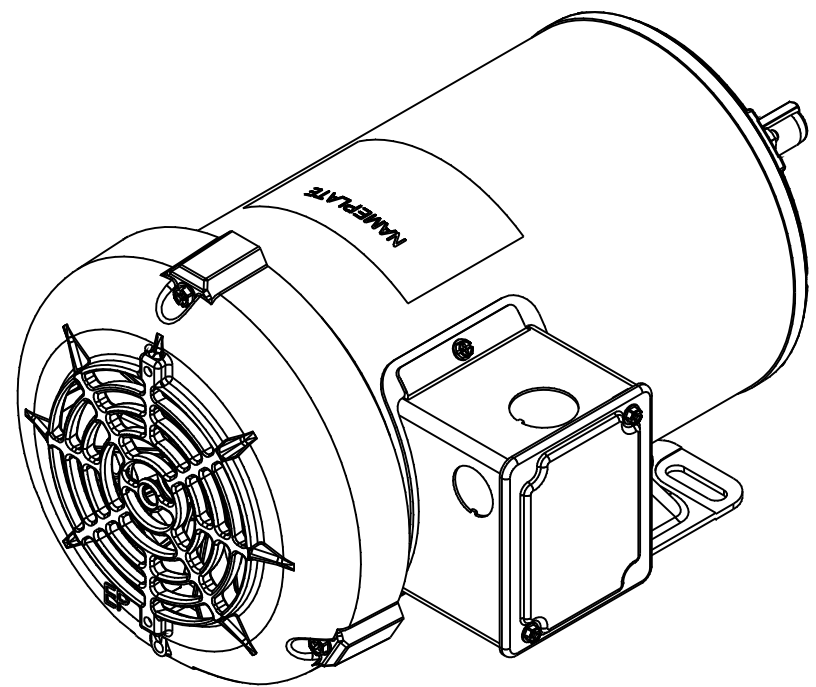
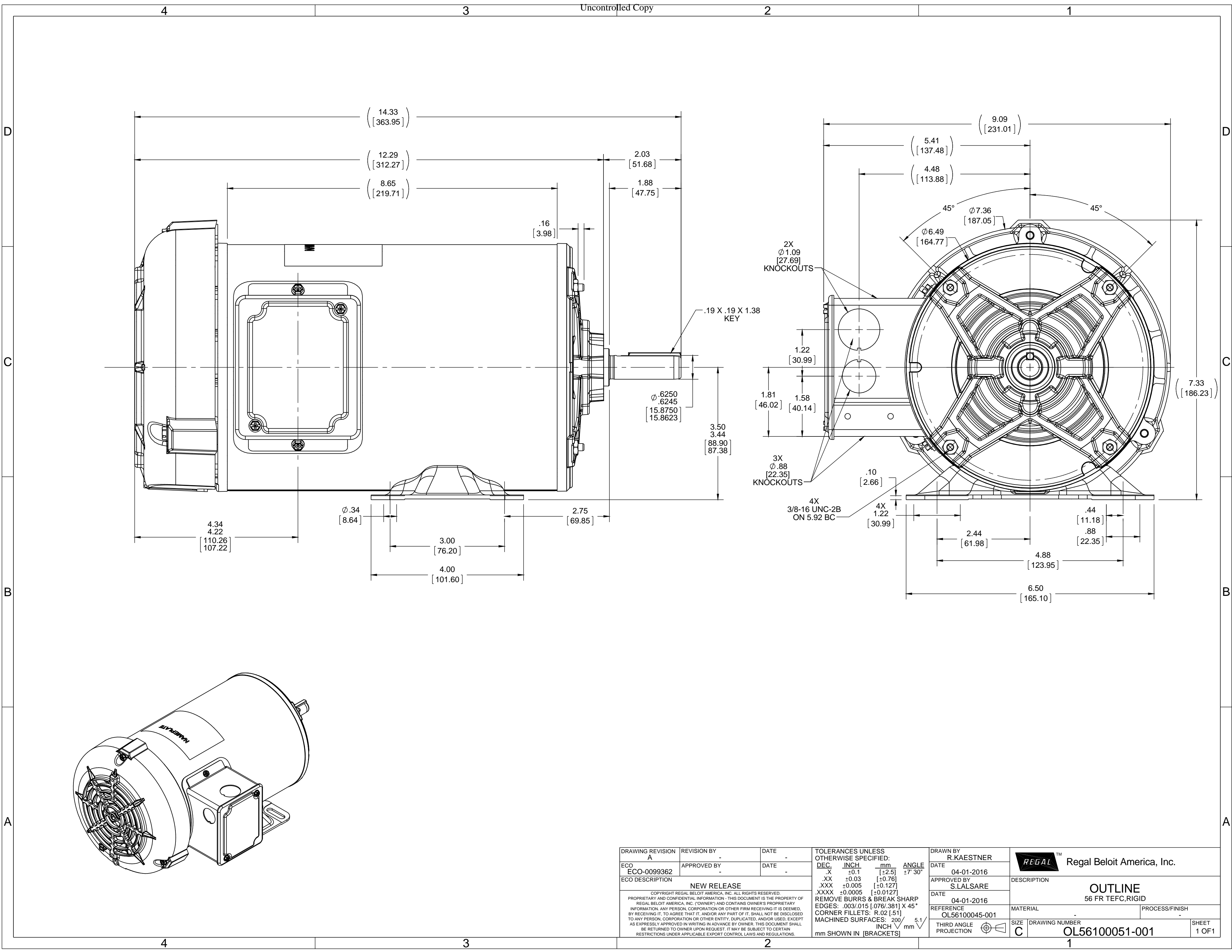

DRAWING REVISION A	REVISION BY -	DATE -	TOLERANCES UNLESS OTHERWISE SPECIFIED: DEC. INCH mm ANGLE .X ±0.1 [±2.5] ±7° 30' .XX ±0.03 [±0.76] .XXX ±0.005 [±0.127] .XXXX ±0.0005 [±0.0127]	DRAWN BY R. KAESTNER	Regal Beloit America, Inc.
ECO ECO-0099362	APPROVED BY -	DATE -	REMOVE BURRS & BREAK SHARP EDGES: .003/.015 [0.076/.381] X 45° CORNER FILLETS: R.02 [51] MACHINED SURFACES: 200 INCH mm 5.1 mm SHOWN IN [BRACKETS]	DATE 04-01-2016	
ECO DESCRIPTION NEW RELEASE				APPROVED BY S. LALSARE	MATERIAL -
<small>COPYRIGHT REGAL BELOIT AMERICA, INC. ALL RIGHTS RESERVED. PROPRIETARY AND CONFIDENTIAL INFORMATION - THIS DOCUMENT IS THE PROPERTY OF REGAL BELOIT AMERICA, INC. ("OWNER") AND CONTAINS OWNER'S PROPRIETARY INFORMATION. ANY PERSON, CORPORATION OR OTHER FIRM RECEIVING IT IS DEEMED, BY RECEIVING IT, TO AGREE THAT IT, AND/OR ANY PART OF IT, SHALL NOT BE DISCLOSED TO ANY PERSON, CORPORATION OR OTHER ENTITY, DUPLICATED, AND/OR USED, EXCEPT AS EXPRESSLY APPROVED IN WRITING IN ADVANCE BY OWNER. THIS DOCUMENT SHALL BE RETURNED TO OWNER UPON REQUEST. IT MAY BE SUBJECT TO CERTAIN RESTRICTIONS UNDER APPLICABLE EXPORT CONTROL LAWS AND REGULATIONS.</small>				DATE 04-01-2016	PROCESS/FINISH -
				REFERENCE OL56100045-001	DRAWING NUMBER OL56100051-001
				THIRD ANGLE PROJECTION	SIZE C
					SHEET 1 OF 1

LOW VOLTAGE

HIGH VOLTAGE

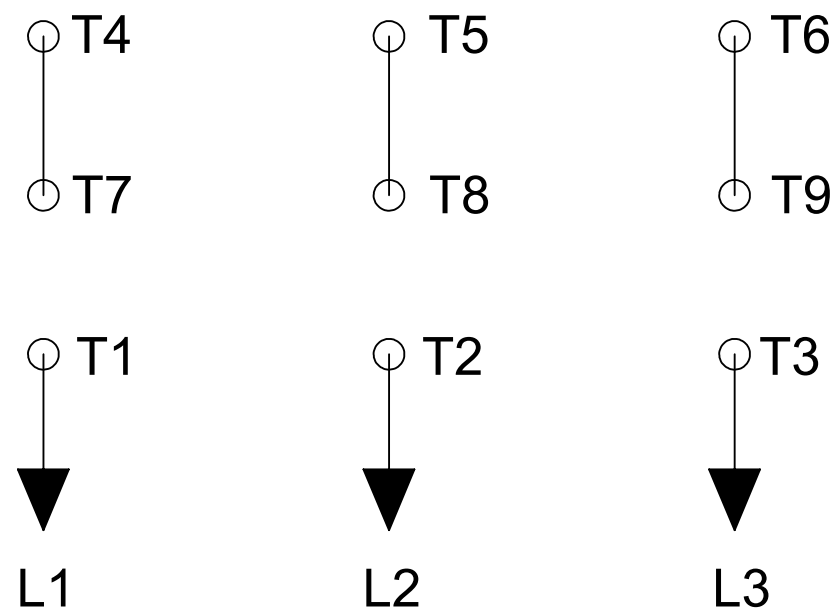
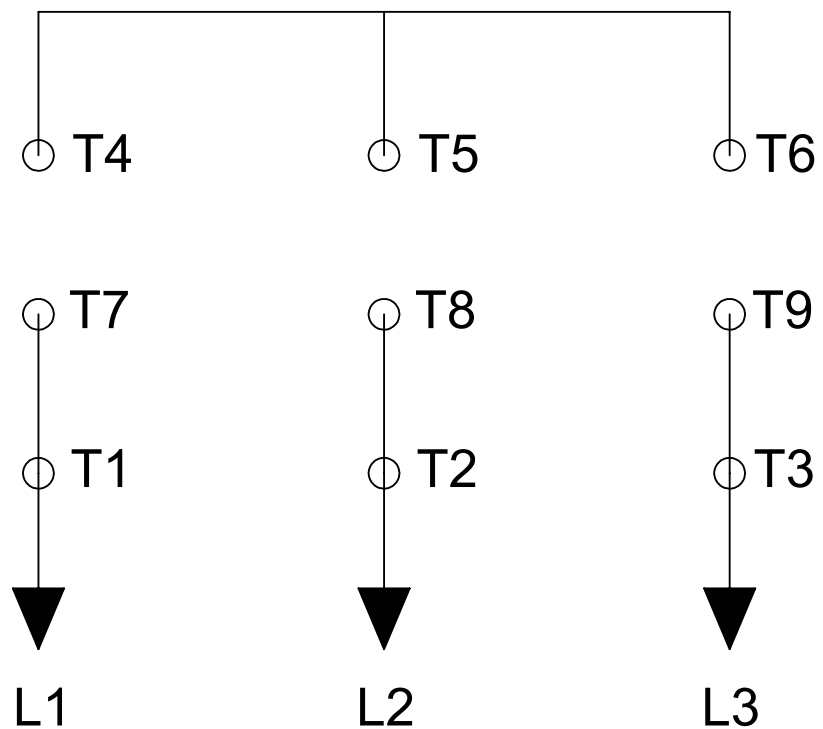

DD10038-001

ROTATION CCW-LE TO REVERSE INTERCHANGE ANY TWO LINE LEADS

PLATE: 41365

SLOT: 22

DRAWING REVISION A	REVISION BY G. RODRIGUEZ	DATE 05-09-2016	TOLERANCES UNLESS OTHERWISE SPECIFIED: DEC. INCH mm ANGLE .X ±0.1 [±2.5] ±0.5° .XX ±0.01 [±0.25] .XXX ±0.005 [±0.127] .XXXX ±0.0005 [±0.0127] REMOVE BURRS & BREAK SHARP EDGES: .003/.015 [0.076/.381] X 45° CORNER FILLETS: R.02 [.51] MACHINED SURFACES: 125/3.2 INCH/mm mm SHOWN IN [BRACKETS]	DRAWN BY G. RODRIGUEZ	REGAL ™ Regal Beloit America, Inc.		
ECO	APPROVED BY E. MARTINEZ	DATE 05-09-2016		DATE 05-09-2016			
ECO DESCRIPTION <small>COPYRIGHT REGAL BELOIT AMERICA, INC. ALL RIGHTS RESERVED. PROPRIETARY AND CONFIDENTIAL INFORMATION - THIS DOCUMENT IS THE PROPERTY OF REGAL BELOIT AMERICA, INC. ("OWNER") AND CONTAINS OWNER'S PROPRIETARY INFORMATION. ANY PERSON, CORPORATION OR OTHER FIRM RECEIVING IT IS DEEMED, BY RECEIVING IT, TO AGREE THAT IT, AND/OR ANY PART OF IT, SHALL NOT BE DISCLOSED TO ANY PERSON, CORPORATION OR OTHER ENTITY, DUPLICATED, AND/OR USED, EXCEPT AS EXPRESSLY APPROVED IN WRITING IN ADVANCE BY OWNER. THIS DOCUMENT SHALL BE RETURNED TO OWNER UPON REQUEST. IT MAY BE SUBJECT TO CERTAIN RESTRICTIONS UNDER APPLICABLE EXPORT CONTROL LAWS AND REGULATIONS.</small>				APPROVED BY E. MARTINEZ	DESCRIPTION CONN DIAGRAM-NAMEPLATE		
				REFERENCE	MATERIAL	PROCESS/FINISH	
				THIRD ANGLE PROJECTION	SIZE B	DRAWING NUMBER DD10038-001	SHEET 1 OF 1