

PRODUCT INFORMATION PACKET



Model No: HSQ1102
Catalog No: HSQ1102
Pool Pump Motor, 1.0 HP, 1 Ph, 60 Hz, 230/115 V, 3600 RPM, Y56Y Frame, ODP



Regal and Century are trademarks of Regal Rexnord Corporation or one of its affiliated companies.
©2024 Regal Rexnord Corporation, All Rights Reserved. MC017097E





Nameplate Specifications

Phase	1	Output HP	1.0 Hp
Output KW	0.75 kW	Voltage	230/115 V
Speed	3450 rpm	Service Factor	1.85
Frame	Y56Y	Enclosure	Open Drip Proof
Thermal Protection	Thermally Protected	Ambient Temperature	60 °C
Frequency	60 Hz	Current	8.8-7.5/15.0 A
Duty	Continuous	Insulation Class	F
UL	Recognized	CSA	Y

Technical Specifications

Electrical Type	Capacitor Start, Capacitor Run, Single Or Dual Voltage	Poles	2
Rotation	Counterclockwise Pump End	Mounting	Square Flange
Motor Orientation	Horizontal	Drive End Bearing	BALL
Opp Drive End Bearing	BALL	Frame Material	Rolled Steel
Shaft Type	1/2 THREADED	Overall Length	13.39 in
Frame Length	9.00 in	Shaft Diameter	0.625 in
Shaft Extension	0.91 in		
Outline Drawing	HSQ1102-S01	Connection Drawing	17536729.PCX

This is an uncontrolled document once printed or downloaded and is subject to change without notice. Date Created:11/13/2024

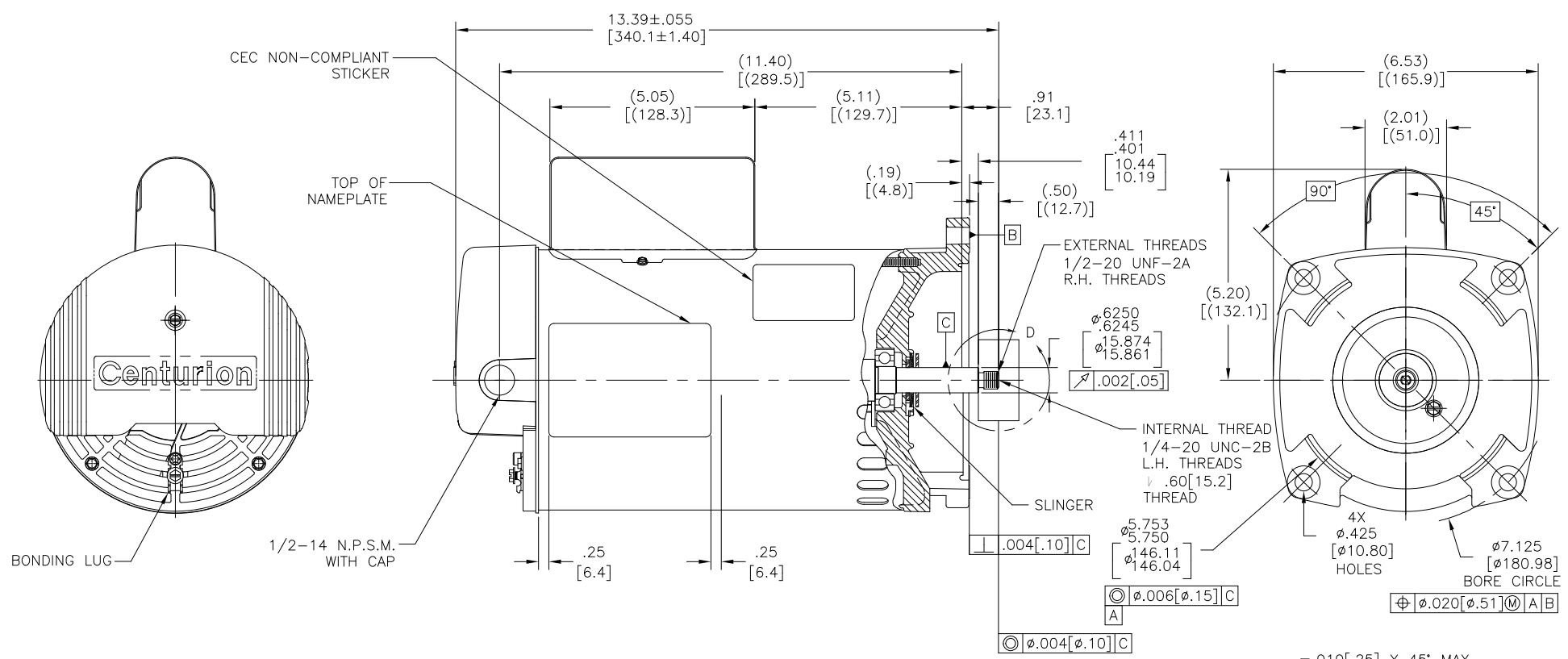

NAMEPLATE DATA	EXTERNAL CONNECTION DIAGRAM	NOTES
MODEL: 196336 CUST PN: HSQ1102 HP: 1.0 SF: 1.85 ROT: CCWPE RPM: 3450 TYPE: CP CODE: G FORM: --- FRAME: Y 56 Y VOLTS: 208-230/115 AMPS: 6.5-6.0/12.0 MAX AMPS: 8.8-7.5/15.0 SF AMPS: --- PH: 1 HZ: 60 INS: F AMB: 60°C DUTY: CONT ENCLOSURE: ODP THERMALLY PROTECTED	<p>175367-29</p> <p>GREEN (GROUND)</p> <p>HIGH VOLTAGE SHOWN. ROTATE DIAL COW TO 115 FOR LOW VOLTAGE.</p> <p>USE COPPER CONDUCTORS ONLY. INSTALL MOTOR WITH VENTS DOWN.</p> <p>ACCEPTABLE FOR FIELD WIRING</p>	<ol style="list-style-type: none"> FOR THREADED SHAFT EXT. ECCENTRICITY OF THREADED PORTION OF SHAFT IS HELD WITHIN .004[.10] TOTAL GAGE READING WITH THE INDICATOR ON O.D. OF GROUND RING GAGE AS SHOWN. THE GAGE BEING STATIONARY WITH RESPECT TO THE ROTOR. END PLAY NOT TO EXCEED .010[.25] MEASURED WITH NO THRUST ALL DIMENSIONS SHOWN IN PARENTHESIS ARE REFERENCE DIMENSIONS. FINISH PAINT TO BE BLACK. GREEN GROUND SCREW LOCATED UNDER COVER TO BE INSTALLED WITH A .09[2.3] MIN. GAP FOR EASY CONNECTION. CONNECTED FOR 230V. DUAL VOLTAGE MOTOR. SEE CONNECTION DIAGRAM TO CHANGE VOLTS TO 115V.

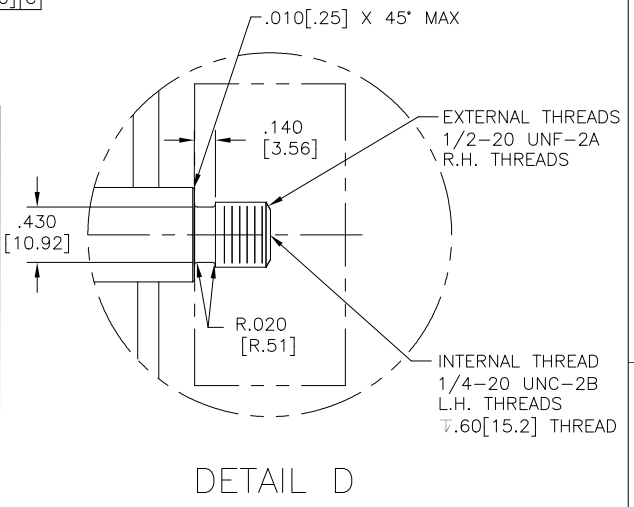

PERFORMANCE CURVE	APPROVED SAMPLE
01165901	0604251AP2
UL COMPONENT	CSA
FILE# CCN# FILE# GUIDE#	
E14663 PRG2 LR4642 4211-01	
CUSTOMER	DISTRIBUTION

DRAWING REVISION	REVISION BY	DATE	TOLERANCES UNLESS OTHERWISE SPECIFIED	ANGLE	DRAWN BY:	MOE	DATE:	DESCRIPTION
IN	S JIMENEZ	11-07-2024	DEC. INCH mm	±0.1 [±2.5]	08-07-2007	REGAL™	Regal Beloit America, Inc.	
ECR-0238401	S JIMENEZ	11-07-2024	.XX ±0.02 [±0.51]	∠.005 [∠0.127]	APPROVED BY:			MODEL-PFHP-56FR OUTLINE
ECO DESCRIPTION			.XXX ±0.005 [±0.127]	REMOVE BURRS & BREAK SHARP EDGES .003/.015 [0.076/.381]	DATE:			
SEE ECR			CORNER FILLETS .02 [5.1]	MACHINED SURFACES √	REFERENCE			
<small>COPYRIGHT REGAL BELOIT AMERICA, INC. ALL RIGHTS RESERVED. PROPRIETARY AND CONFIDENTIAL INFORMATION - THIS DOCUMENT IS THE PROPERTY OF REGAL BELOIT AMERICA, INC. (OWNER) AND COMPANY OWNER'S PROPRIETARY INFORMATION. ANY PERSON, CORPORATION OR OTHER ENTITY RECEIVING IT IS DEMAND, BY RECEIVING IT, TO AGREE THAT IT AND/OR ANY PART OF IT, SHALL NOT BE DISCLOSED TO ANY PERSON, CORPORATION OR OTHER ENTITY, DUPLICATED, AND/OR USED, EXCEPT AS EXPRESSLY APPROVED IN WRITING IN ADVANCE BY OWNER. THIS DOCUMENT SHALL BE RETURNED TO OWNER UPON REQUEST. IT MAY BE SUBJECT TO CERTAIN RESTRICTIONS UNDER APPLICABLE EXPORT CONTROL LAWS AND REGULATIONS.</small>			<small>THIRD ANGLE PROJECTION</small>		<small>SIZE DWG NO</small> C HSQ1102	<small>SHEET</small> 1		