

PRODUCT INFORMATION PACKET



Model No: OB3204V1

Catalog No: OB3204V1

General Purpose Motor, 2 HP, 3 Ph, 60/50 Hz, 200-230/460 V, 1800 RPM, 56HZ Frame, ODP



Regal and Century are trademarks of Regal Rexnord Corporation or one of its affiliated companies.

©2022 Regal Rexnord Corporation, All Rights Reserved. MC017097E





Nameplate Specifications

Output HP	2 Hp	Output KW	1.5 kW
Frequency	60 Hz	Voltage	200-230/460 V
Current	6.8/3.4 A	Speed	1725 rpm
Service Factor	1.15	Phase	3
Efficiency	80 %	Duty	Continuous
Insulation Class	B	Frame	56HZ
Enclosure	Open Drip Proof	Thermal Protection	No Protection
Ambient Temperature	40 °C	UL	Recognized
CSA	Y	CE	N
Number of Speeds	1		

Technical Specifications

Electrical Type	Polyphase	Starting Method	Across The Line
Poles	4	Rotation	Reversible
Mounting	Rigid Base	Drive End Bearing	Ball
Opp Drive End Bearing	Ball	Frame Material	Rolled Steel
Shaft Type	Keyed	Overall Length	13.22 in
Frame Length	8.19 in	Shaft Diameter	0.874 in
Shaft Extension	2.38 in		
Outline Drawing	12076-003		

This is an uncontrolled document once printed or downloaded and is subject to change without notice. Date Created:12/21/2022

REV	ECO	REV BY	DATE	APPD	DATE
C	ECO-0170298	D.SURYAWANSHI	07/10/2019		

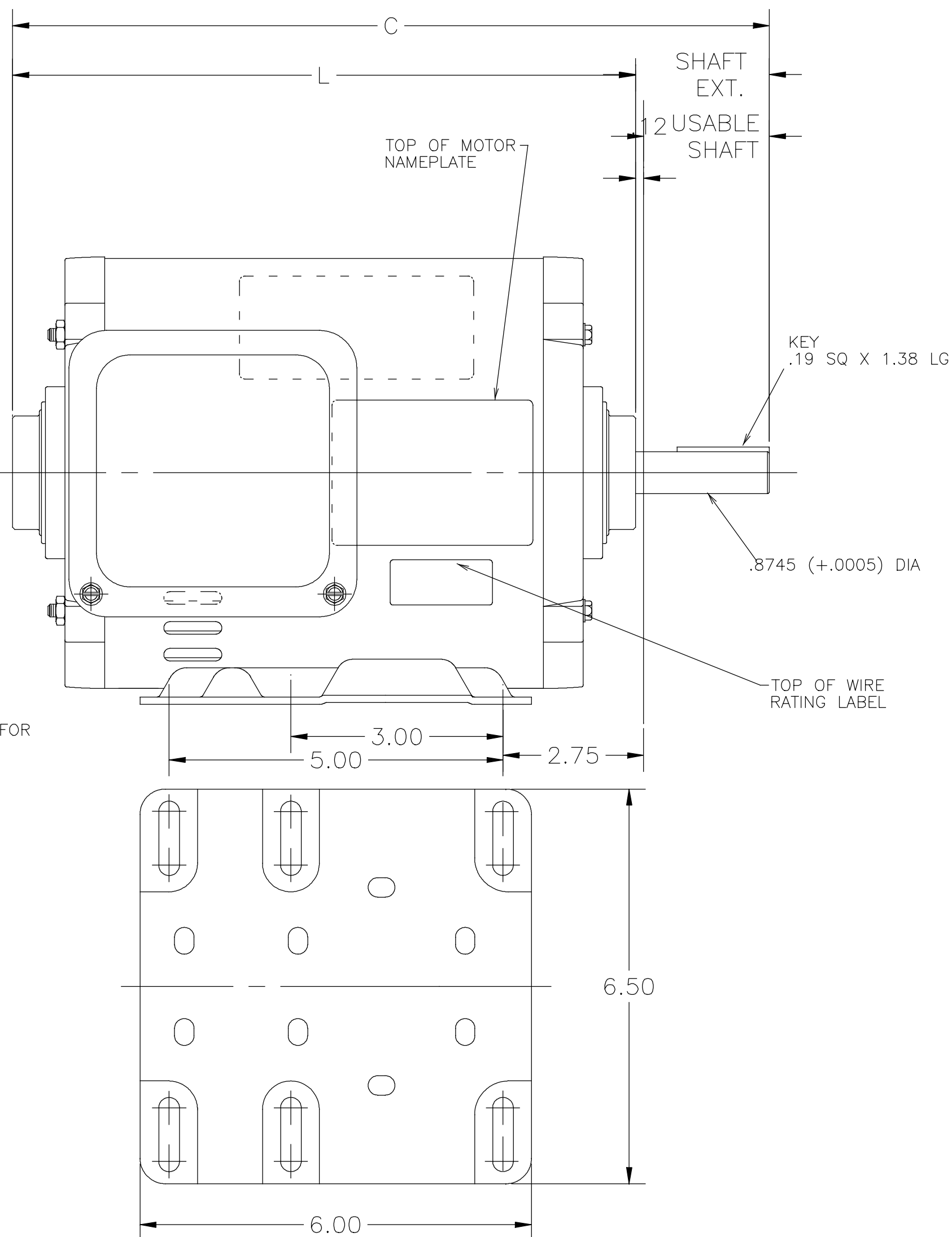
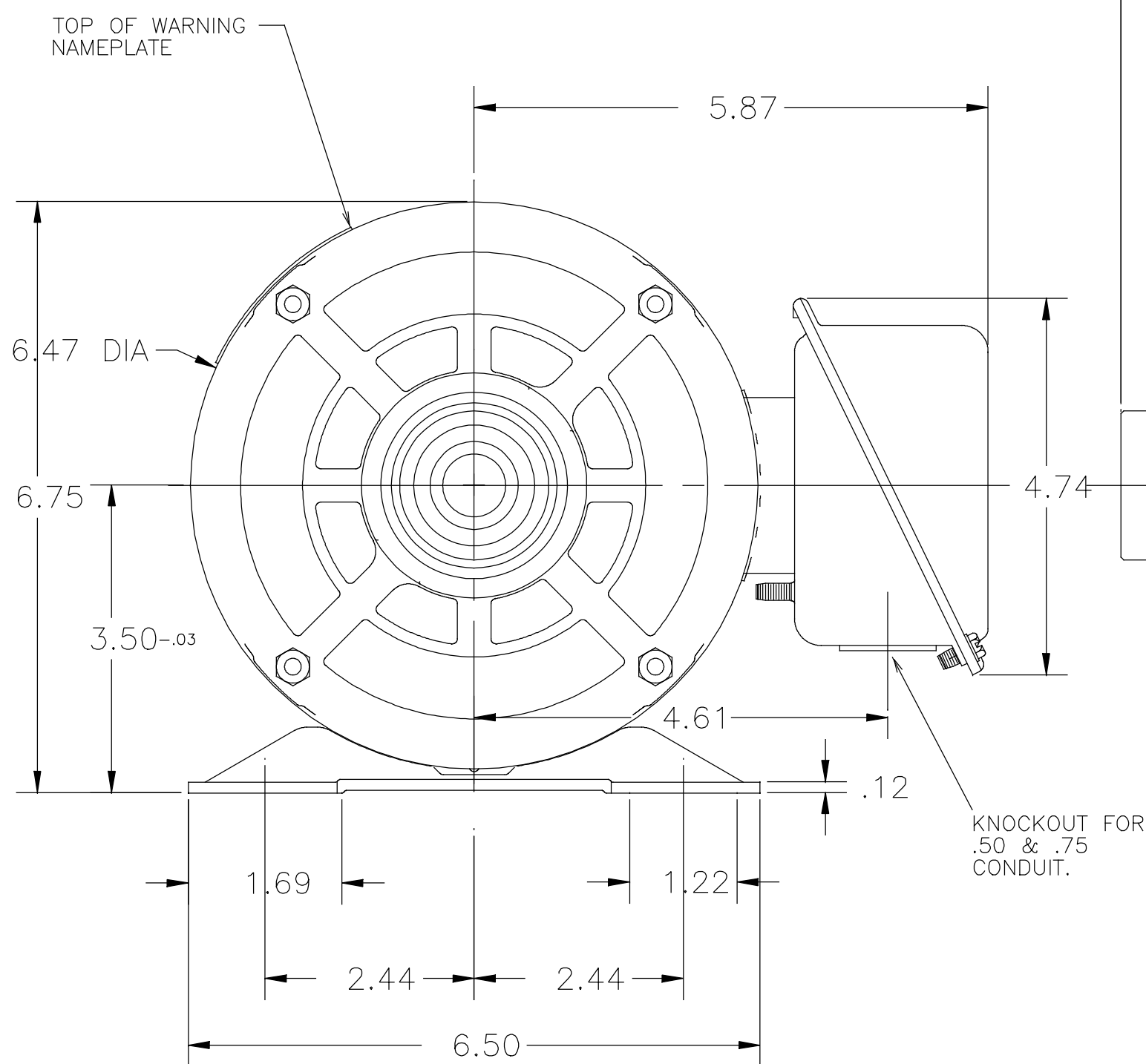

FIRST MODEL	REF FRAME LENGTH	C	L	SHAFT EXT.	USABLE SHAFT EXT.
P56B43A01	8.062	13.22	10.84	2.38	2.26
P56C18C82	8.062	13.22	10.84	2.38	2.26

GEOMETRIC CHARACTERISTICS & SYMBOLS
 ▽ FLATNESS
 — STRAIGHTNESS
 < ANGLARITY
 ⊥ PERPENDICULARITY (SQUARENESS)
 // PARALLELISM
 ○ ROUNDNESS (CIRCULARITY)
 ⌀ CYLINDRICITY
 △ PROFILE OF ANY SURFACE
 ∩ PROFILE OF ANY LINE
 ↑ RUNOUT
 ⊕ TRUE POSITION
 ⊙ CONCENTRICITY
 = SYMMETRY

UNLESS OTHERWISE SPECIFIED
 DIM. TOLERANCES ARE AS FOLLOWS:
 INCH X XX XXX XXXX
 ±.1 ±.02 ±.005 ±.0005
 mm ±0.5 ±0.13 ±0.013
 ANG. ±.50 DEG
 REMOVE BURRS & BREAK SHARP EDGES:
 INCH .003-.015 mm 0.1-0.4
 CORNER FILLETS TO:
 INCH .020 mm 0.5
 MACHINE SURFACES:
 INCH 125 mm 3.2
 METRIC DIMS. SHOWN IN [BRACKETS]

DR BY: KLINE 04-06-1998
 APPD:
 THIRD ANGLE PROJECTION
 EDS DATE EDS DATE
 FORMAT REV F
 CONFIDENTIAL: THIS DRAWING AND ITS INFORMATION ARE THE EXCLUSIVE AND CONFIDENTIAL PROPERTY OF A.O. SMITH CORP. AND ARE NOT TO BE DISCLOSED, DUPLICATED, DISTRIBUTED OR OTHERWISE USED WITHOUT THE WRITTEN CONSENT OF A.O. SMITH CORP.
 -ALL RIGHTS RESERVED. ASME Y14.5M 1994

REGAL™ Regal Beloit America, Inc.

DESCRIPTION
 OUTLINE

SIZE C DWG NO 12076-003

SCALE NONE SHEET 1