

PRODUCT INFORMATION PACKET



Model No: R1052

Catalog No: R1052

1/2 HP OEM Replacement (Except HVAC) Motor, 1 phase, 3600 RPM, 230/115 V, 48Y Frame, ODP
General Purpose Pump Motors



Regal and Century are trademarks of Regal Rexnord Corporation or one of its affiliated companies.
©2021 Regal Rexnord Corporation, All Rights Reserved. MC017097E





Nameplate Specifications

Output HP	1/2 Hp	Output KW	0.37 kW
Frequency	60 Hz	Voltage	230/115 V
Current	6.2/12.4 A	Speed	3450 rpm
Service Factor	1.9	Phase	1
Duty	Continuous	Insulation Class	B
Frame	48Y	Enclosure	Open Drip Proof
Thermal Protection	Automatic	Ambient Temperature	40 °C
UL	No	CSA	Y
CE	N	Number of Speeds	1

Technical Specifications

Electrical Type	Capacitor Start Induction Run	Starting Method	Across The Line
Poles	2	Rotation	Counterclockwise Pump End
Mounting	Round	Drive End Bearing	Ball
Opp Drive End Bearing	Ball	Frame Material	Rolled Steel
Shaft Type	Threaded	Overall Length	12.45 in
Frame Length	5.63 in	Shaft Diameter	0.625 in
Shaft Extension	2.945 in		
Outline Drawing	R1052-S01	Connection Drawing	627103-006

This is an uncontrolled document once printed or downloaded and is subject to change without notice. Date Created:10/07/2021

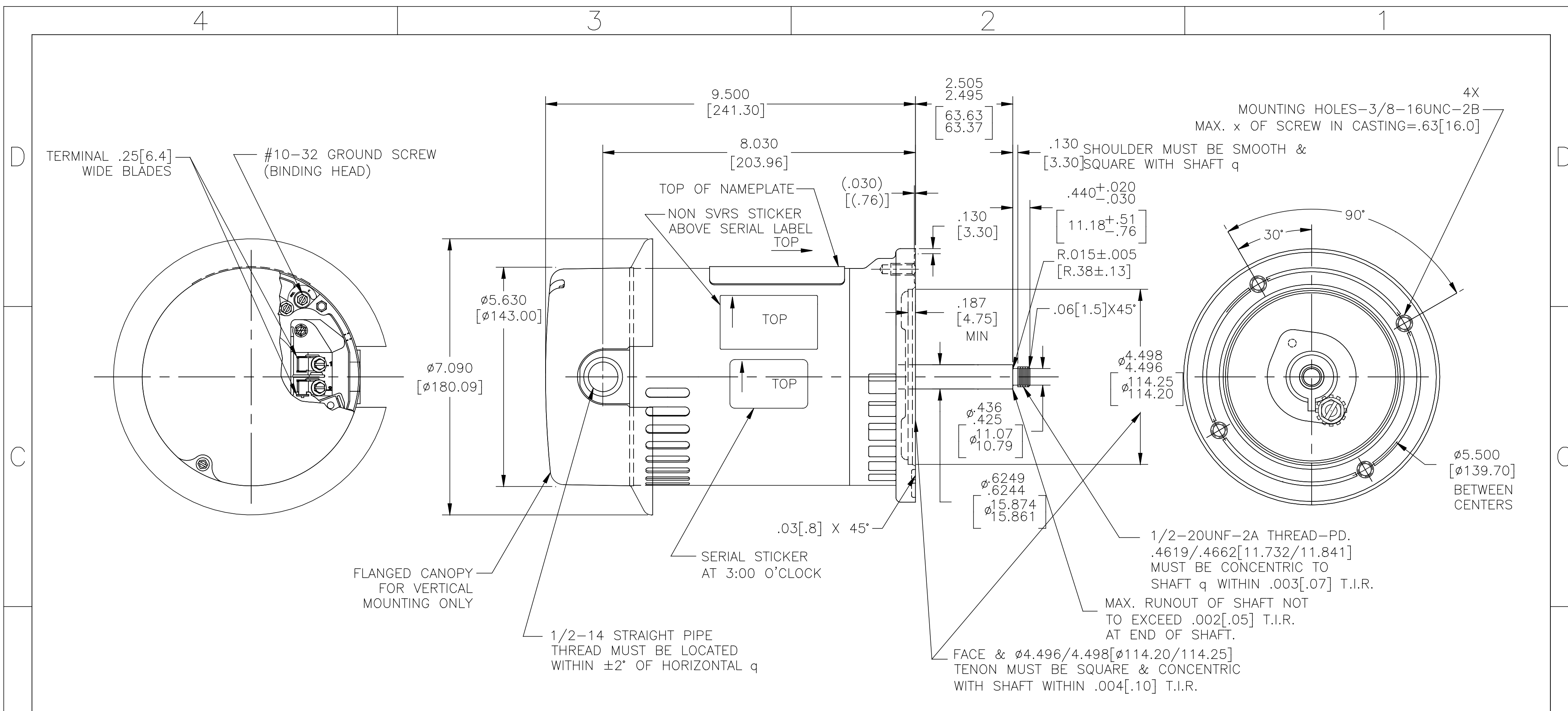

NAMEPLATE DATA		EXTERNAL CONNECTION DIAGRAM	NOTES
MODEL: C48J2FC11A2 CUST PN: R1052 HP: 1/2 SF: 1.9 ROT: CCWPE RPM: 3450 TYPE: C CODE: M FORM: FRAME: 48Y VOLTS: 230/115 AMPS: MAX AMPS: 6.2/12.4 SF AMPS: - PH: 1 HZ: 60 INS: B AMB: 40 DUTY: CONT ENCLOSURE: ODP THERMALLY PROTECTED		<p>GRD GREEN (GROUND)</p> <p>HIGH VOLTAGE SHOWN. ROTATE DIAL CCW TO 115 FOR LOW VOLTAGE.</p> <p>USE COPPER CONDUCTORS ONLY. INSTALL MOTOR WITH VENTS DOWN.</p> <p>ACCEPTABLE FOR FIELD WIRING</p>	<ol style="list-style-type: none"> 1. FINISH PAINT TO BE SATIN BLACK. 2. .44[11.1] WRENCH FLATS ON SHAFT-FOR ACCESS TO THIS WRENCH FLAT REMOVE END COVER. 3. CARBON STEEL SHAFT EXT. 4. LIMITS ON AMPLITUDE OF VIBRATION MEASURED AT BEARING HOUSING = .001[.03]. 5. CONNECT MOTOR FOR 230 VOLTS. QUICK VOLTAGE CHANGE PLUG INCLUDED ON TERMINAL BOARD. VOLT STICKER TO READ THAT CONNECTED VOLTAGE. 6. MOTOR ASSEMBLY REF.: 624622-001

PERFORMANCE CURVE		APPROVED SAMPLE	
C48J2W13			
UL COMPONENT		CSA	
FILE#	CCN#	FILE#	GUIDE#
-	-	LR43341	4211-01
CUSTOMER		DISTRIBUTION SERVICES	

DRAWING REVISION	REVISION BY	DATE	TOLERANCES UNLESS OTHERWISE SPECIFIED	DRAWN BY:	REGAL™ Regal Beloit America, Inc.
C	F.NAVARRO	09-27-2016	DEC. INCH mm ANGLE	IDT	
ECO	APPROVED BY	DATE	.X ±0.1 [±2.5] ±0.5°	DATE:	
ECO-0109446	-	-	.XX ±0.02 [±0.51]	04-11-2003	
SEE ECO			.XXX ±0.005 [±0.127]	APPROVED BY:	
			.XXXX ±0.0005 [±0.0127]	WB	
			REMOVE BURRS & BREAK SHARP EDGES .003/.015 [0.076/.381]	DATE:	
			CORNER FILLETS .02 [51]	05-29-2003	
			MACHINED SURFACES 125/32	REFERENCE	
			mm SHOWN IN [BRACKETS]	MATERIAL	
				PROCESS/FINISH	
				THIRD ANGLE PROJECTION	
				SIZE DWG NO	
				C R1052	
				SHEET	
				1	

REV	ECO	REV BY	DATE	APPD	DATE
B	0001487	D.MUÑOZ	04-13-2009	M.ARGUELLES	04-13-2009

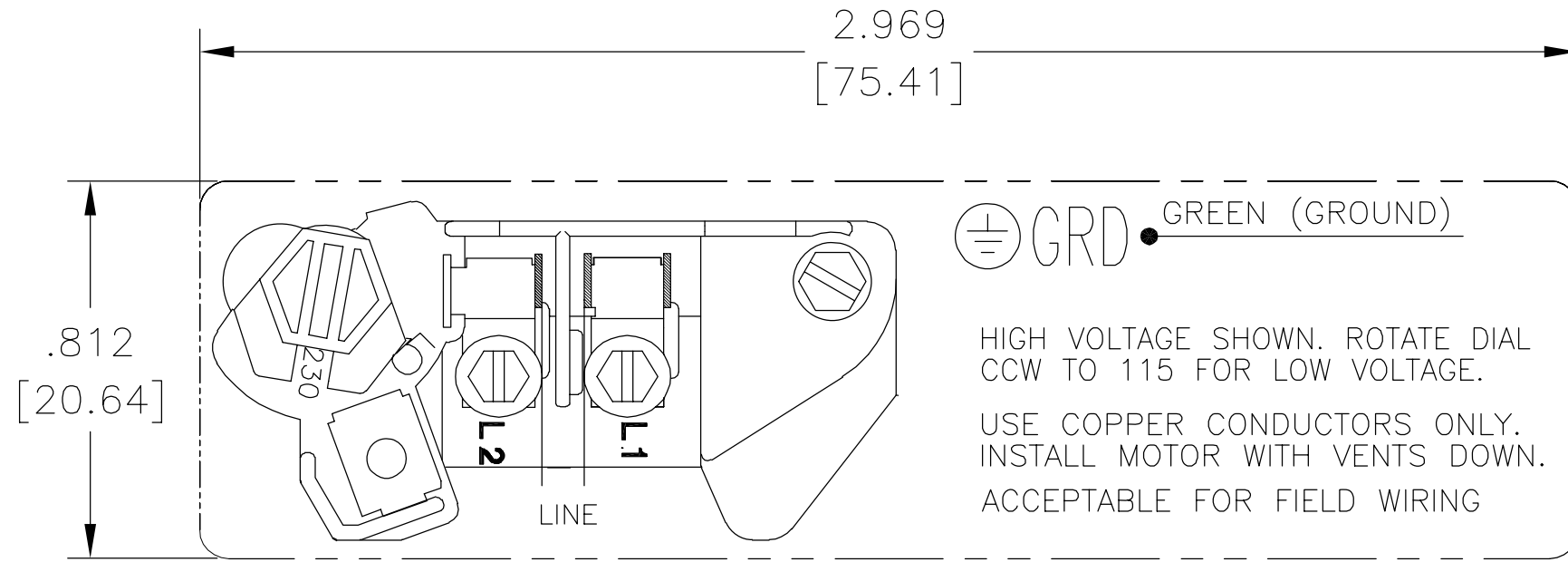

DUAL VOLTAGE

NOTE:

1. FOR USE WITH 616231 NAME PLATE BLANK.
2. — — — — INDICATES DIMENSIONAL LIMITS.
3. DIE MUST PRODUCE A LEGIBLE IMPRESSION.

GEOMETRIC CHARACTERISTICS & SYMBOLS

- ▭ FLATNESS
- STRAIGHTNESS
- ∠ ANGULARITY
- ⊥ PERPENDICULARITY (SQUARENESS)
- // PARALLELISM
- ROUNDNESS (CIRCULARITY)
- ⊘ CYLINDRICITY
- △ PROFILE OF ANY SURFACE
- ⌒ PROFILE OF ANY LINE
- ↑ RUNOUT
- ⊕ TRUE POSITION
- ◎ CONCENTRICITY
- ⊖ SYMMETRY

UNLESS OTHERWISE SPECIFIED
DIM. TOLERANCES ARE AS FOLLOWS:

INCH	±.1	±.02	±.005	±.0005
mm	±0.5	±0.13	±0.013	

ANG. ±.50 DEG

REMOVE BURRS & BREAK SHARP EDGES:

INCH	.003-.015	mm	0.1-0.4
------	-----------	----	---------

CORNER FILLETS TO:

INCH	.020	mm	0.5
------	------	----	-----

MACHINE SURFACES:

INCH	125	mm	3.2
------	-----	----	-----

METRIC DIMS. SHOWN IN [BRACKETS]

DR BY:	Daniel Muñoz	04-13-2009
APPD:		
THIRD ANGLE PROJECTION		EDS DATE 02-22-2009 FORMAT REV F
CONFIDENTIAL: THIS DRAWING AND ITS INFORMATION ARE THE EXCLUSIVE AND CONFIDENTIAL PROPERTY OF A.O. SMITH CORP. AND ARE NOT TO BE DISCLOSED, DUPLICATED, DISTRIBUTED OR OTHERWISE USED WITHOUT THE WRITTEN CONSENT OF A.O. SMITH CORP. -ALL RIGHTS RESERVED. ASME Y14.5M 1994		

AC Smith innovation has a name.		ELECTRICAL PRODUCTS COMPANY A DIVISION OF A. O. SMITH CORPORATION	
DESCRIPTION			
CONNECTION DIAGRAM EXTERNAL			
SIZE	A	DWG NO	627103-006
SCALE	NONE	SHEET	1

REVISION:	ECO	REVISADO POR:	FECHA:	APROBADO POR:	FECHA:
B	0001487	D.MUÑOZ	04-13-2009	M.ARGUELLES	04-13-2009

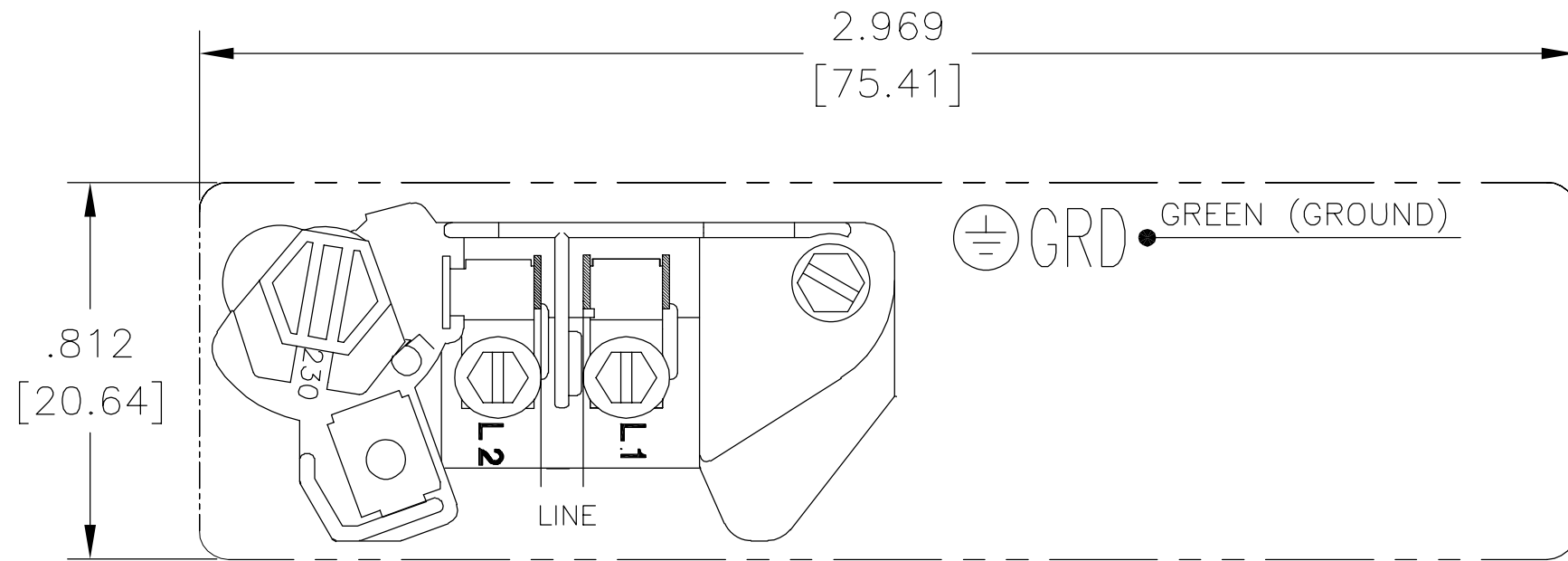

VOLTAJE DOBLE

NOTAS:

1. PARA USARSE CON LA PLACA DE DATOS EN BLANCO 616231.
2. — — — — — INDICA LIMITES DIMENSIONALES.
3. EL DADO DEBE PRODUCIR UNA IMPRESION LEGIBLE.

CARACTERISTICAS DE GEOMETRIA Y SIMBOLOS

- ▭ PLANICIDAD
- RECTITUD
- ∠ ANGULARIDAD
- ⊥ PERPENDICULARIDAD (A ESCUADRA)
- // PARALELISMO
- REDONDEZ (CIRCULARIDAD)
- ⊘ CILINDRICIDAD
- △ PERFIL DE CUALQUIER SUPERFICIE
- ∩ PERFIL DE CUALQUIER LINEA
- ↑ VARIACION
- ⊕ POSICION REAL
- ◎ CONCENTRICIDAD
- ≡ SIMETRIA

A MENOS QUE SE ESPECIFIQUE DE OTRA MANERA, LAS TOLERANCIAS DE LAS DIMS; SON LAS SIGUIENTES:

	X	XX	XXX	XXXX
PULG	±.1	±.02	±.005	±.0005
mm	±0.5	±0.13	±0.013	
ANG.	±.50 GRADOS			
ELIMINAR REBABAS Y ORILLAS FILOSAS DEL BORDE.				
	PULG .003-.015	mm 0.1-0.4		
FILETEAR ESQUINA:	PULG .020 mm 0.5			
MAQUINAR SUPERFICIES	PULG 125 mm 3.2			
DIMS METRICAS MOSTRADAS [PARENTESIS]				

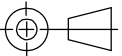
DIBUJADO POR: Daniel Muñoz	04-13-2009
APROBADO POR:	
TERCER ANGULO DE PROYECCION	
FECHA EDS: 02-22-2009	REV. FORMATO: F
CONFIDENCIAL: ESTE DIBUJO Y SU INFORMACION SON PROPIEDAD DE USO EXCLUSIVO Y CONFIDENCIAL DE A.O.SMITH CORP. Y NO DEBERAN SER REVELADOS, DUPLICADOS, DISTRIBUIDOS O USARSE DE OTRA MANERA SIN EL CONSENTIMIENTO ESCRITO DE A.O. SMITH CORP.	
-TODOS LOS DERECHOS RESERVADOS.ASME Y14.5M 1994	

 ELECTRICAL PRODUCTS COMPANY <small>A DIVISION OF A. O. SMITH CORPORATION</small>	
DESCRIPCION: CONNECTION DIAGRAM EXTERNAL	
TAMAÑO: A	NUMERO DE DIBUJO: 627103-006
ESCALA:NONE	HOJA: 1

版本	ECO	编制	日期	批准	日期
B	0001487	D.MUÑOZ	04-13-2009	M.ARGUELLES	04-13-2009

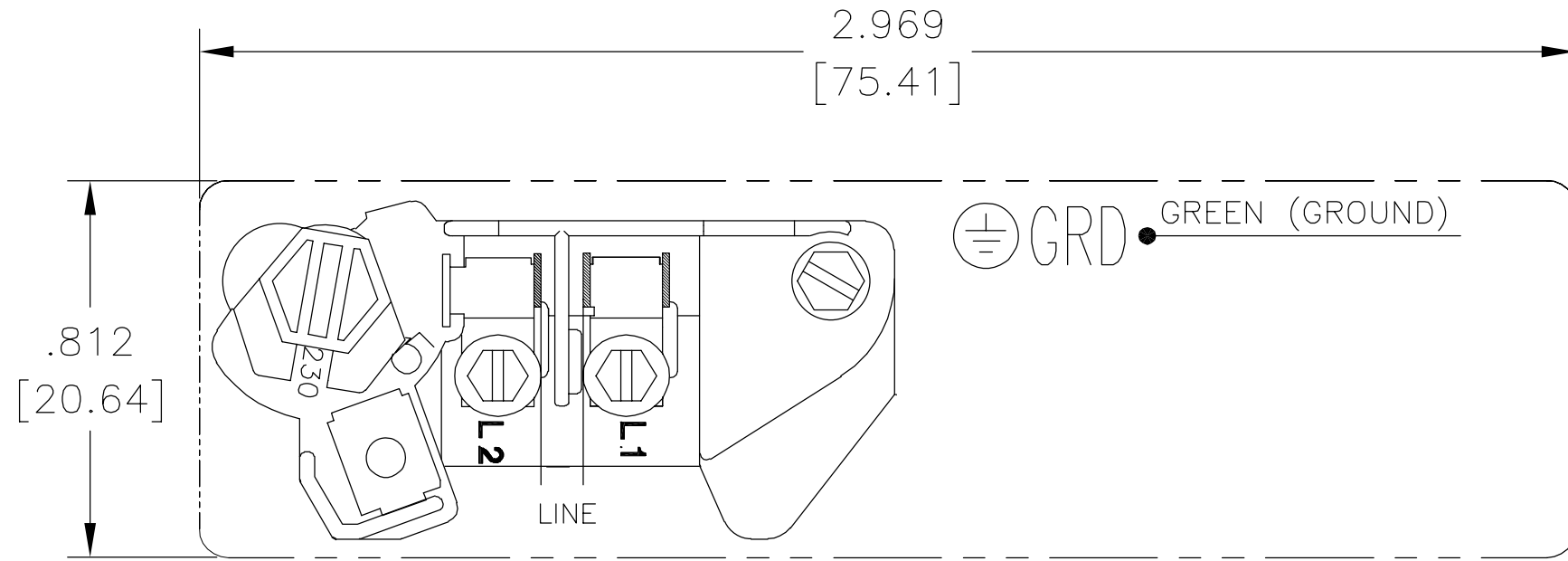

- 形位公差
- 平面度
- 直线度
- ∠ 倾斜度
- ⊥ 垂直度
- // 平行度
- 圆度
- ⊘ 圆柱度
- △ 面轮廓度
- ⌒ 线轮廓度
- ↗ 圆跳动
- ⊕ 位置度
- ◎ 同轴度
- ≡ 对称度

除另有注明
尺寸公差如下:

	X	XX	XXX	XXXX
英寸	±.1	±.02	±.005	±.0005
毫米	±0.5	±0.13	±0.013	
角度	±.50 度			
清理毛刺和尖棱				
英寸	.003-.015	毫米	0.1-0.4	
内圆角				
英寸	.020	毫米	0.5	
表面粗糙度				
英制	125	米制	3.2	

米制尺寸显示在 []

绘图:	Daniel Muñoz	04-13-2009
批准:		
第三角投影		图纸格式发布日期 02-22-2009 图纸格式版本 F
机密: 本图纸及相关信息所有权归A. O. SMITH公司所有。未经A. O. SMITH公司书面授权, 不得泄露、复制、传播或作其他用途。—版权所有		
ASME Y14.5M 1994		

		ELECTRICAL PRODUCTS COMPANY <small>A DIVISION OF A. O. SMITH CORPORATION</small>	
名称		CONNECTION DIAGRAM EXTERNAL	
图幅	A	图号	627103-006
比例	NONE	页号	1