

# PRODUCT INFORMATION PACKET

FASCO®

Model No: UB560  
Catalog No: UB560  
6 WATT Refrigeration Motor, 1550 RPM, 230 Volts, Unit Bearing, TEAO



Regal and Fasco are trademarks of Regal Rexnord Corporation or one of its affiliated companies.  
©2022 Regal Rexnord Corporation, All Rights Reserved. MC017097E

RegalRexnord



### Nameplate Specifications

Output Watts	<b>6 W</b>	Frequency	<b>60 Hz</b>
Voltage	<b>230 V</b>	Current	<b>0.18 A</b>
Speed	<b>1550 rpm</b>	Service Factor	<b>1</b>
Phase	<b>1</b>	Duty	<b>Continuous</b>
Insulation Class	<b>B</b>	Frame	<b>UNIT BEARING</b>
Enclosure	<b>Totally Enclosed Air Over</b>	Thermal Protection	<b>Impedance</b>
Ambient Temperature	<b>40 °C</b>	UL	<b>Recognized</b>
CSA	<b>Y</b>	CE	<b>N</b>
Number of Speeds	<b>1</b>		

### Technical Specifications

Electrical Type	<b>Shaded Pole</b>	Starting Method	<b>Across The Line</b>
Poles	<b>4</b>	Rotation	<b>Clockwise Opposite Shaft End</b>
Mounting	<b>2 BOSS/OSE 5 HOLES</b>	Drive End Bearing	<b>Unit</b>
Opp Drive End Bearing	<b>Unit</b>	Frame Material	<b>Aluminum</b>
Shaft Type	<b>Threaded</b>	Frame Length	<b>3.12 in</b>
Shaft Diameter	<b>1/4x20 in</b>	Shaft Extension	<b>.415 in</b>
Outline Drawing	<b>UB560-S01</b>		

This is an uncontrolled document once printed or downloaded and is subject to change without notice. Date Created:11/29/2022

NOTE: OUTLINE DIMENSIONS ON WHICH NO LIMIT IS SPECIFIED ARE NOMINAL AND NOT GUARANTEED AS TO TOLERANCE. ADDITIONAL INFORMATION ON TOLERANCES WILL BE FURNISHED ON SPECIFIC REQUEST.

NOTE: MOUNTING SCREW TORQUE 3.5 FT.LB.MAX.

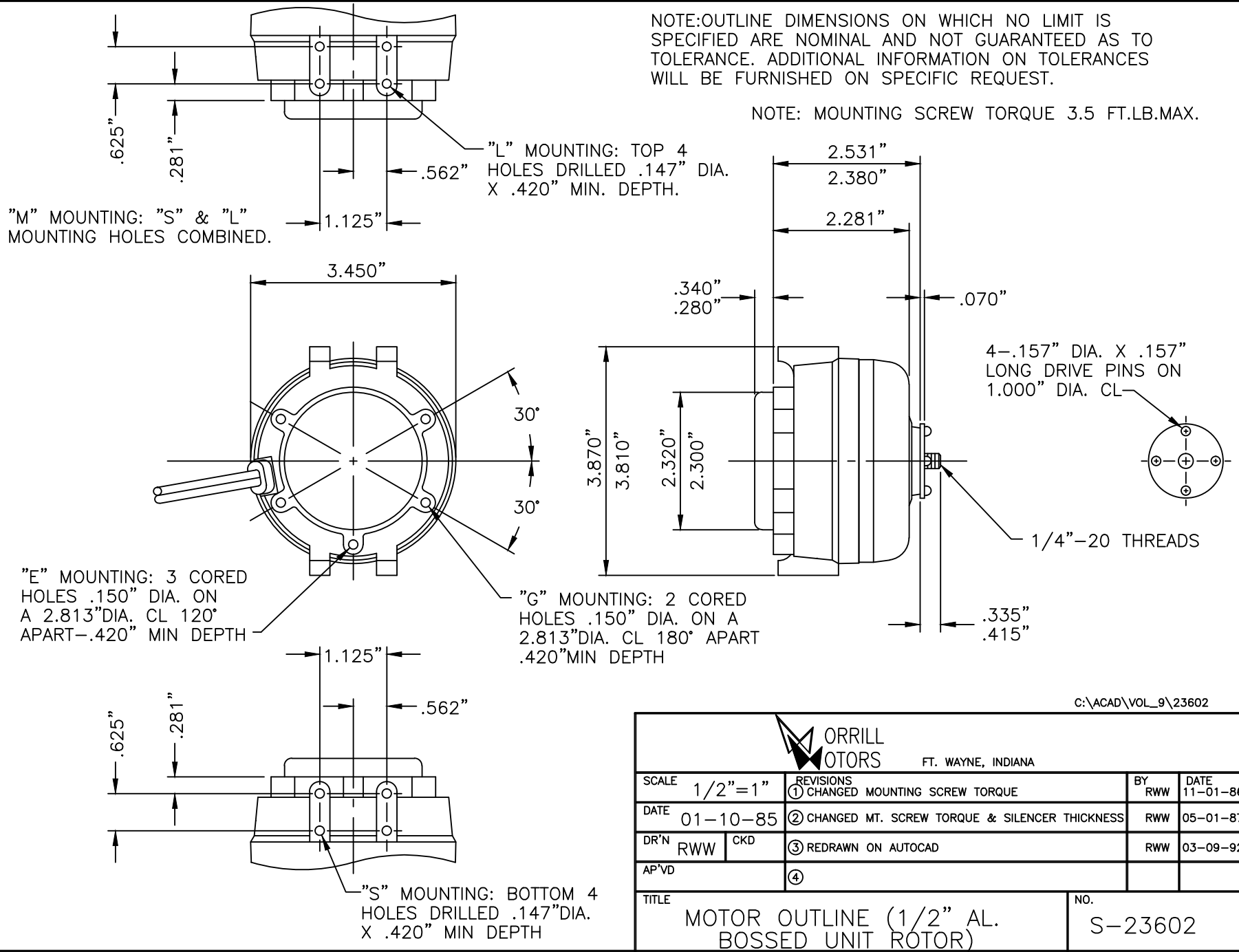

C:\ACAD\VOL\_9\23602

 <b>ORRILL MOTORS</b> FT. WAYNE, INDIANA			
SCALE	1/2"=1"	REVISIONS	BY DATE
DATE	01-10-85	① CHANGED MOUNTING SCREW TORQUE	RWW 11-01-86
DR'N	RWW CKD	② CHANGED MT. SCREW TORQUE & SILENCER THICKNESS	RWW 05-01-87
AP'VD		③ REDRAWN ON AUTOCAD	RWW 03-09-92
		④	
TITLE			NO.
MOTOR OUTLINE (1/2" AL. BOSSED UNIT ROTOR)			S-23602