

PRODUCT INFORMATION PACKET

FASCO®

Model No: UB576
Catalog No: UB576
35 WATT Refrigeration Motor, 1500 RPM, 230 Volts, Unit Bearing, TEAO



Regal and Fasco are trademarks of Regal Rexnord Corporation or one of its affiliated companies.
©2022 Regal Rexnord Corporation, All Rights Reserved. MC017097E

RegalRexnord



Nameplate Specifications

Output Watts	35 W	Frequency	60 Hz
Voltage	230 V	Current	0.7 A
Speed	1500 rpm	Service Factor	1
Phase	1	Duty	Continuous
Insulation Class	A	Frame	UNIT BEARING
Enclosure	Totally Enclosed Air Over	Thermal Protection	Thermally Protected
Ambient Temperature	40 °C	UL	Recognized
CSA	Y	CE	N
Number of Speeds	1		

Technical Specifications

Electrical Type	Shaded Pole	Starting Method	Across The Line
Poles	4	Rotation	Clockwise Opposite Shaft End
Mounting	2 BOSS/OSE 3 HOLES	Drive End Bearing	Unit
Opp Drive End Bearing	Unit	Frame Material	Cast Iron
Shaft Type	Threaded	Frame Length	3.84 in
Shaft Diameter	1/4x20 in	Shaft Extension	.52 in
Outline Drawing	UB576		

This is an uncontrolled document once printed or downloaded and is subject to change without notice. Date Created:11/29/2022

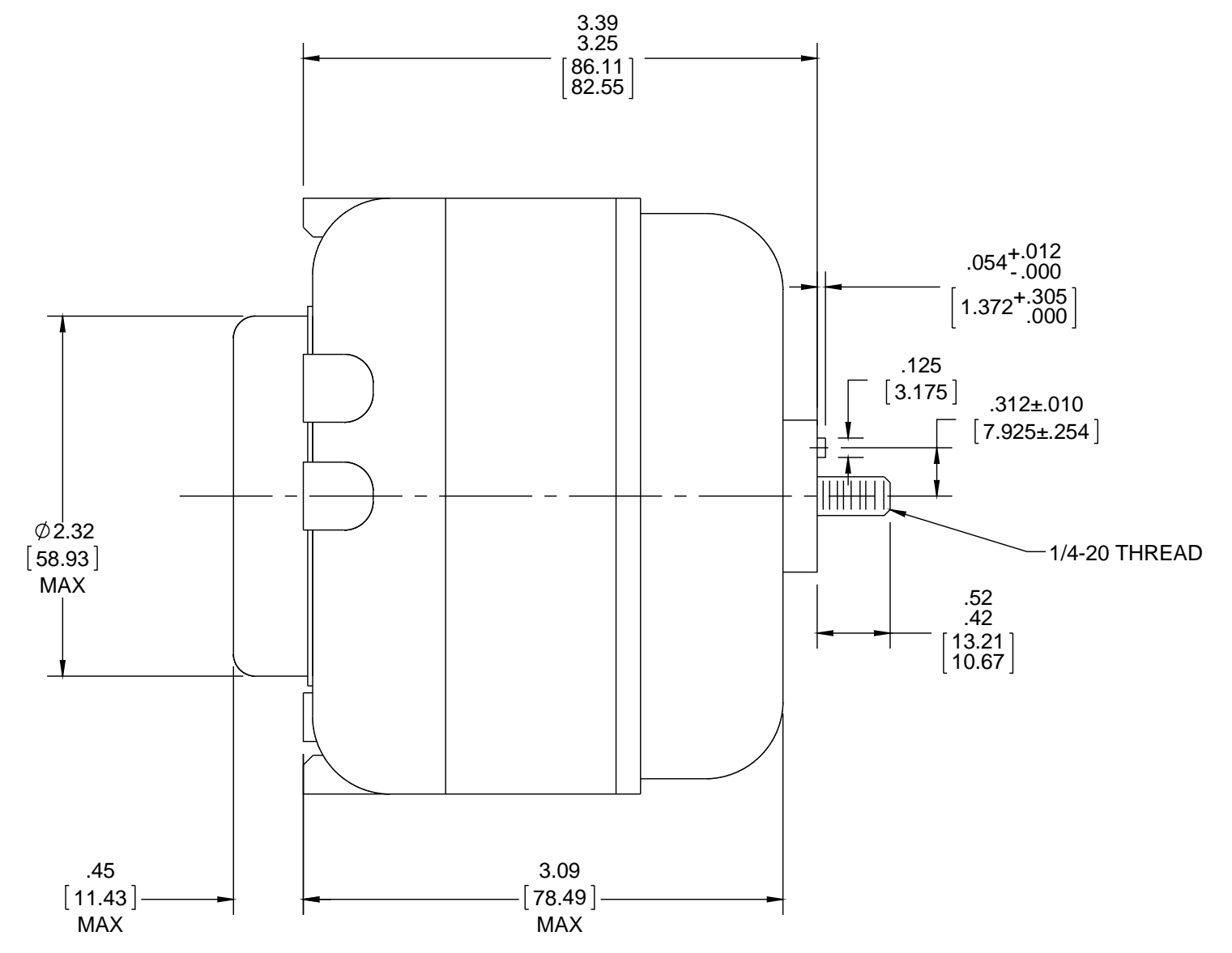
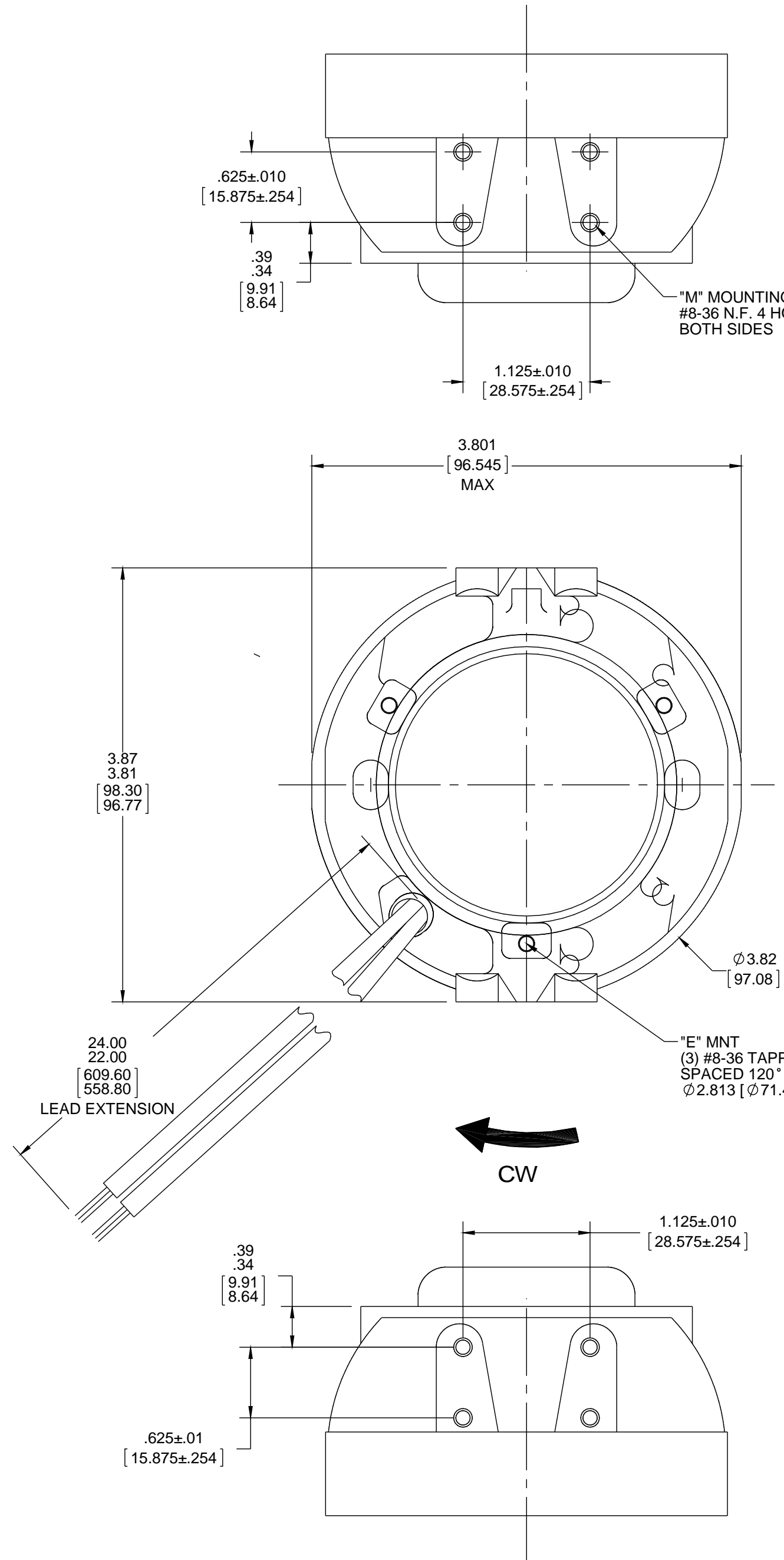

OUTLINE DIMENSIONS ON WHICH NO LIMIT IS SPECIFIED ARE NOMINAL AND NOT GUARANTEED AS TO TOLERANCE. ADDITIONAL INFORMATION ON TOLERANCE WILL BE FURNISHED ON SPECIFIC REQUEST.

DRAWING REVISION A	REVISION BY A.SUN	DATE 04-20-2016	TOLERANCES UNLESS OTHERWISE SPECIFIED: DEC. INCH mm ANGLE .X ±0.1 [±2.5] ±7° 30' .XX ±0.02 [±0.51] .XXX ±0.005 [±0.127] .XXXX ±0.0005 [±0.0127]	DRAWN BY A.SUN	Regal Beloit America, Inc.
ECO ECO-0100244	APPROVED BY A.SUN	DATE 04-20-2016	DATE 04-20-2016	DATE 04-20-2016	
ECO DESCRIPTION SEE ECO			REFERENCE ESPL35EM2	APPROVED BY A.SUN	DESCRIPTION MODEL-SFHP-UB
<small>COPYRIGHT REGAL BELOIT AMERICA, INC. ALL RIGHTS RESERVED. PROPRIETARY AND CONFIDENTIAL INFORMATION - THIS DOCUMENT IS THE PROPERTY OF REGAL BELOIT AMERICA, INC. (OWNER) AND CONTAINS OWNER'S PROPRIETARY INFORMATION. ANY PERSON, CORPORATION OR OTHER FIRM RECEIVING IT IS DEEMED, BY RECEIVING IT, TO AGREE THAT IT, AND/OR ANY PART OF IT, SHALL NOT BE DISCLOSED TO ANY PERSON, CORPORATION OR OTHER ENTITY, DUPLICATED, AND/OR USED, EXCEPT AS EXPRESSLY APPROVED IN WRITING IN ADVANCE BY OWNER. THIS DOCUMENT SHALL BE RETURNED TO OWNER UPON REQUEST. IT MAY BE SUBJECT TO CERTAIN RESTRICTIONS UNDER APPLICABLE EXPORT CONTROL LAWS AND REGULATIONS.</small>			MATERIAL	DATE 04-20-2016	PROCESS/FINISH
			MACHINED SURFACES: 200 INCH mm 5.1 mm SHOWN IN [BRACKETS]	THIRD ANGLE PROJECTION	SHEET 1 OF 1
			SIZE C	DRAWING NUMBER UB576	