

PRODUCT INFORMATION PACKET



Model No: USQ1072

Catalog No: USQ1072

Pool Pump Motor, 3/4 HP, 1 Ph, 60 Hz, 230/115 V, 3600 RPM, 48Y Frame, ODP



Regal and Century are trademarks of Regal Rexnord Corporation or one of its affiliated companies.
©2025 Regal Rexnord Corporation, All Rights Reserved. MC017097E





Nameplate Specifications

Phase	1	Output HP	3/4 Hp
Output KW	0.56 kW	Voltage	230/115 V
Speed	3450 rpm	Service Factor	1.27
Frame	48Y	Enclosure	Open Drip Proof
Thermal Protection	Automatic	Ambient Temperature	50 °C
Frequency	60 Hz	Current	6.7/13.4 A
Duty	Continuous	Insulation Class	B
UL	Recognized	CSA	Y
Number of Speeds	1		

Technical Specifications

Electrical Type	Cap Start Motor	Starting Method	Across The Line
Poles	2	Rotation	Counterclockwise Pump End
Mounting	Round	Motor Orientation	Horizontal
Drive End Bearing	Ball	Opp Drive End Bearing	Ball
Frame Material	Rolled Steel	Shaft Type	1/2 Thread
Overall Length	12.19 in	Frame Length	8.31 in
Shaft Diameter	0.625 in	Shaft Extension	0.906 in
Outline Drawing	USQ1072	Connection Drawing	627103-006

This is an uncontrolled document once printed or downloaded and is subject to change without notice. Date Created:12/19/2025

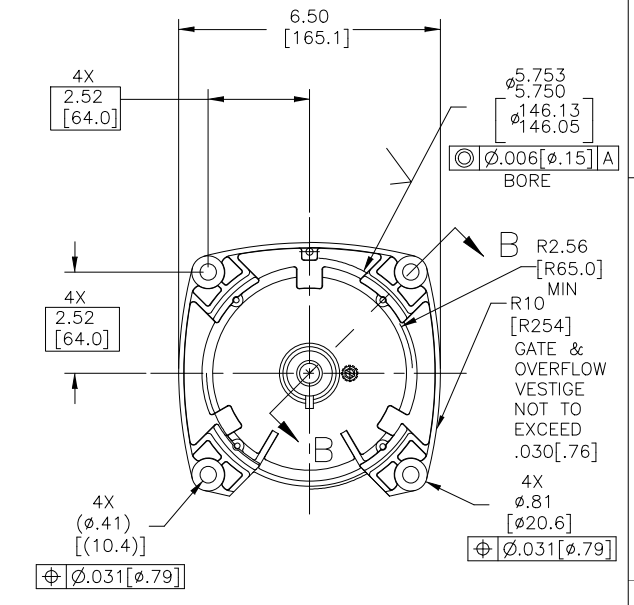
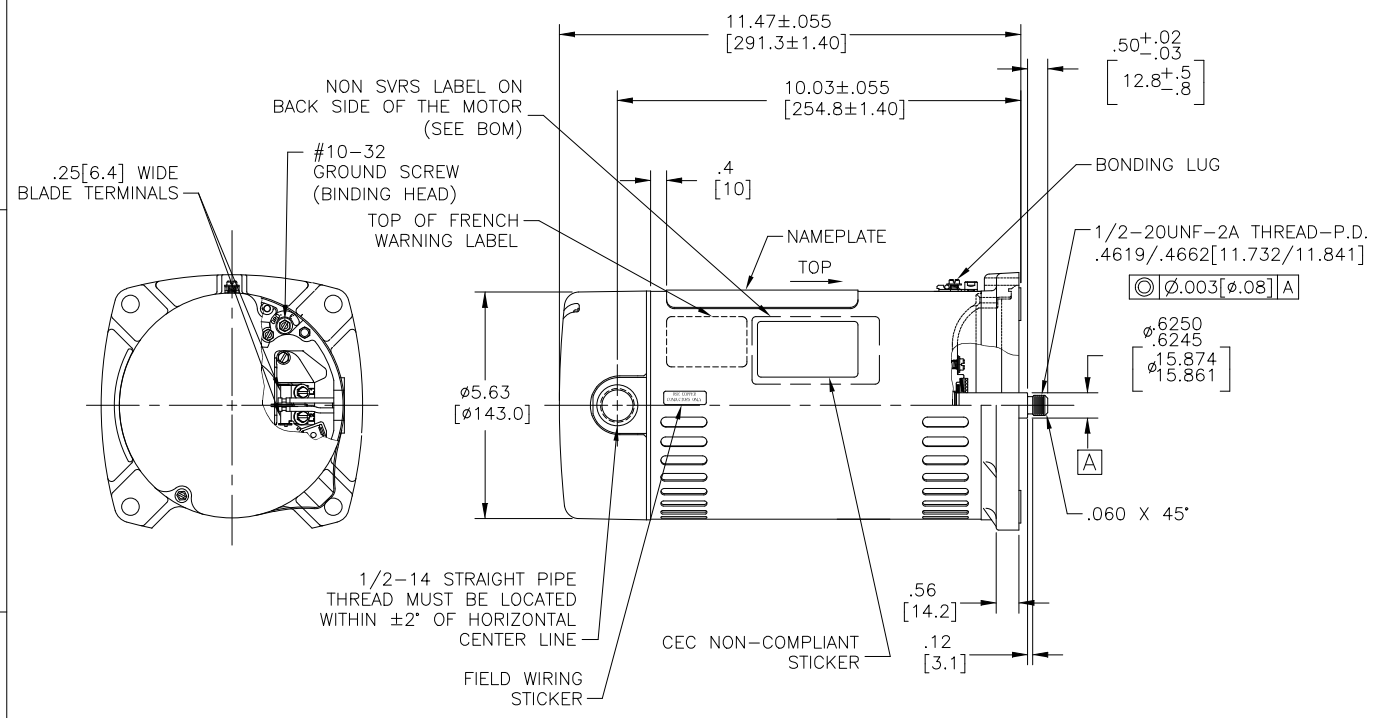

NAMEPLATE DATA

MODEL: C48J2PA105C5
 CUST PN: USQ1072
 HP: 0.75 SF: 1.27
 ROT: CCWPE
 RPM: 3450
 TYPE: UAC CODE: J
 FORM: FRAME: 48 Y

VOLTS: 230/115
 AMPS:
 MAX AMPS: 6.7/13.4
 SF AMPS: -

PH: 1 HZ: 60
 INS: B AMB: 50°C
 DUTY: CONT
 ENCLOSURE: ODP
 THERMALLY PROTECTED

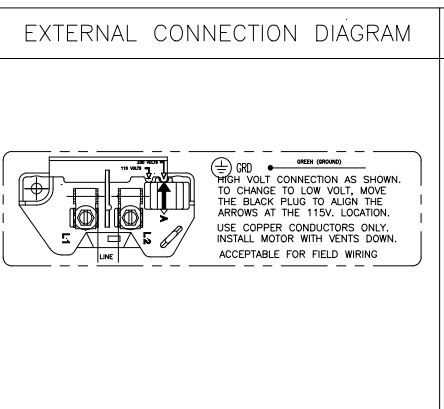

- NOTES
1. FINISH PAINT TO BE SATIN BLACK.
 2. .44[11.2] WRENCH FLATS ON SHAFT-FOR ACCESS TO THIS WRENCH FLAT REMOVE END COVER.
 3. STAINLESS STEEL SHAFT EXT.
 4. LIMITS ON AMPLITUDE OF VIBRATION MEASURED AT BEARING HOUSING = .001.
 5. CONNECTED FOR 230 VOLTS. QUICK VOLTAGE CHANGE DIAL INCLUDED ON THE TERMINAL BOARD.
 6. SUPPORT PAD TO BE PACKED WITH EACH MOTOR
 7. CTQ REQUIREMENT SEE EP000105-008
 8. RoHS & REACH REQUIREMENT SEE EP000014.

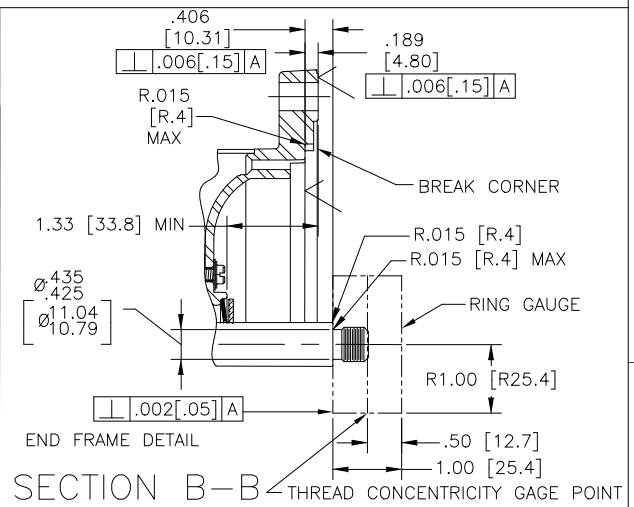

PERFORMANCE CURVE

C48J2W41

UL COMPONENT

CSA

FILE#	CCN#	FILE#	GUIDE#
E25022	XEWR2	LR43341	4211-01

CUSTOMER

DIST. SERVICES

APPROVED SAMPLE

CSA

CRITICAL TO QUALITY CHARACTERISTICS(CTQs)	DRAWING REVISION	REVISION BY	DATE
(P) PROCESS	IN	GELINE,ZHAO	12-11-2025
(E) ENGINEERING	ECO	APPROVED BY	DATE
(A) APPLICATION	ECR-0247757	TRISTIA,ZHAO	12-11-2025
(R) REGULATORY	ECO DESCRIPTION		
(L) LIFE	ADD FRENCH LABEL		

PROPRIETARY AND CONFIDENTIAL INFORMATION - THIS DOCUMENT IS THE PROPERTY OF REGAL BELTO AMERICA, INC. (OWNER) AND COMPANY'S PROPRIETARY INFORMATION. ANY REPRODUCTION OR OTHER FIRM RECEIVING IT IS DENIED. BY RECEIVING IT, TO AGREE THAT IT, AND/OR ANY PART OF IT, SHALL NOT BE DISCLOSED TO ANY PERSON, CORPORATION OR OTHER ENTITY, DUPLICATED, AND/OR USED, EXCEPT AS EXPRESSLY APPROVED IN WRITING IN ADVANCE BY OWNER. THIS DOCUMENT SHALL BE RETURNED TO OWNER UPON REQUEST. IT MAY BE SUBJECT TO CERTAIN RESTRICTIONS UNDER APPLICABLE EXPORT CONTROL LAWS AND REGULATIONS.

TOLERANCES UNLESS OTHERWISE SPECIFIED	ANGLE
DEC. INCH	mm
.X ±0.1	±0.5°
.XX ±0.02	[±0.51]
.XXX ±0.005	[±0.127]
.XXXX ±0.0005	[±0.0127]
REMOVE BURRS & BREAK SHARP EDGES .003/.015 [0.076/.381]	
CORNER FILLETS .02 [5.1]	
MACHINED SURFACES	125
mm SHOWN IN [BRACKETS]	mm ^{3/2}

DRAWN BY:	JLJC	DATE:	05-12-2009
APPROVED BY:		DESCRIPTION:	MODEL-PFHP-48FR OUTLINE
REFERENCE:		MATERIAL:	
THIRD ANGLE PROJECTION		PROCESS/FINISH:	
SIZE	DWG NO	USQ1072	SHEET 1

REV	ECO	REV BY	DATE	APPD	DATE
B	0001487	D.MUÑOZ	04-13-2009	M.ARGUELLES	04-13-2009

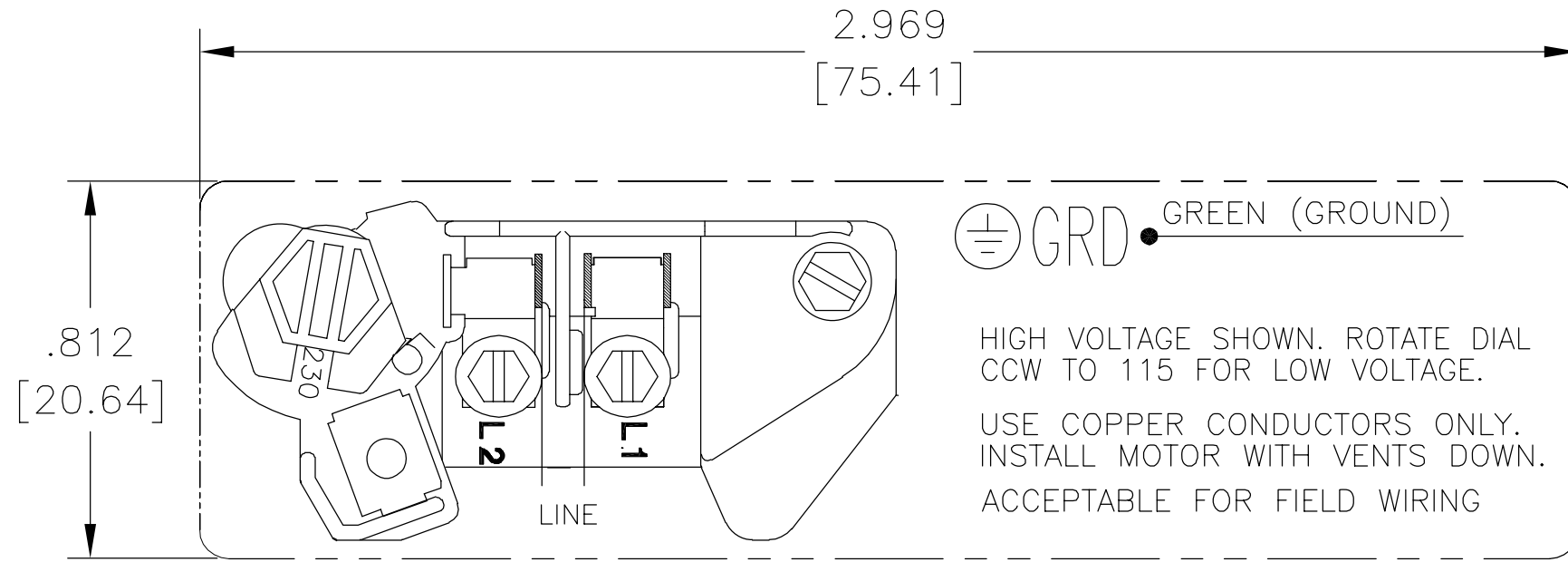

DUAL VOLTAGE

NOTE:

1. FOR USE WITH 616231 NAME PLATE BLANK.
2. — — — — INDICATES DIMENSIONAL LIMITS.
3. DIE MUST PRODUCE A LEGIBLE IMPRESSION.

GEOMETRIC CHARACTERISTICS & SYMBOLS

- ▭ FLATNESS
- STRAIGHTNESS
- ∠ ANGULARITY
- ⊥ PERPENDICULARITY (SQUARENESS)
- // PARALLELISM
- ROUNDNESS (CIRCULARITY)
- ⊘ CYLINDRICITY
- △ PROFILE OF ANY SURFACE
- ⌒ PROFILE OF ANY LINE
- ↑ RUNOUT
- ⊕ TRUE POSITION
- ◎ CONCENTRICITY
- ⊖ SYMMETRY

UNLESS OTHERWISE SPECIFIED
DIM. TOLERANCES ARE AS FOLLOWS:

INCH	±.1	±.02	±.005	±.0005
mm	±0.5	±0.13	±0.013	

ANG. ±.50 DEG

REMOVE BURRS & BREAK SHARP EDGES:

INCH	.003-.015	mm	0.1-0.4
------	-----------	----	---------

CORNER FILLETS TO:

INCH	.020	mm	0.5
------	------	----	-----

MACHINE SURFACES:

INCH	125	mm	3.2
------	-----	----	-----

METRIC DIMS. SHOWN IN [BRACKETS]

DR BY:	Daniel Muñoz	04-13-2009
APPD:		
THIRD ANGLE PROJECTION		EDS DATE 02-22-2009 FORMAT REV F
CONFIDENTIAL: THIS DRAWING AND ITS INFORMATION ARE THE EXCLUSIVE AND CONFIDENTIAL PROPERTY OF A.O. SMITH CORP. AND ARE NOT TO BE DISCLOSED, DUPLICATED, DISTRIBUTED OR OTHERWISE USED WITHOUT THE WRITTEN CONSENT OF A.O. SMITH CORP. -ALL RIGHTS RESERVED. ASME Y14.5M 1994		

		ELECTRICAL PRODUCTS COMPANY <small>A DIVISION OF A. O. SMITH CORPORATION</small>	
DESCRIPTION CONNECTION DIAGRAM EXTERNAL			
SIZE A	DWG NO 627103-006		
SCALE NONE			SHEET 1

REVISION:	ECO	REVISADO POR:	FECHA:	APROBADO POR:	FECHA:
B	0001487	D.MUÑOZ	04-13-2009	M.ARGUELLES	04-13-2009

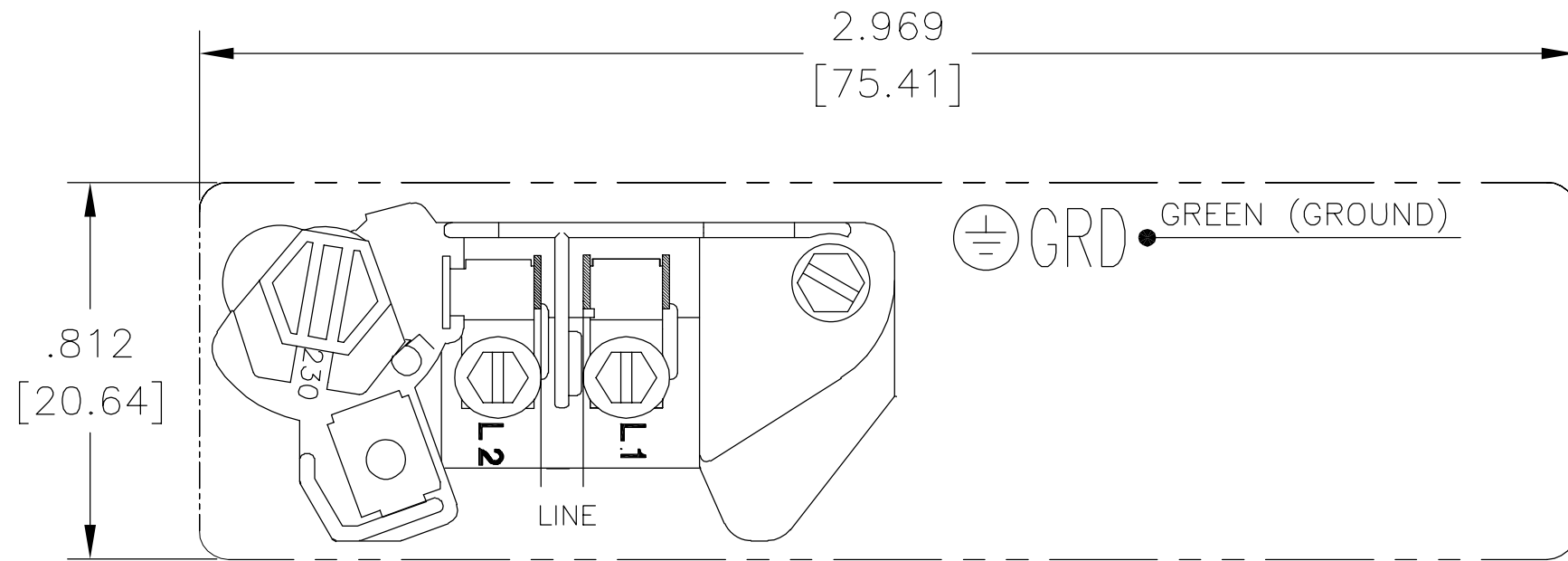

VOLTAJE DOBLE

NOTAS:

1. PARA USARSE CON LA PLACA DE DATOS EN BLANCO 616231.
2. — — — — INDICA LIMITES DIMENSIONALES.
3. EL DADO DEBE PRODUCIR UNA IMPRESION LEGIBLE.

CARACTERISTICAS DE GEOMETRIA Y SIMBOLOS

- ▭ PLANICIDAD
- RECTITUD
- ∠ ANGULARIDAD
- ⊥ PERPENDICULARIDAD (A ESCUADRA)
- // PARALELISMO
- REDONDEZ (CIRCULARIDAD)
- ⊘ CILINDRICIDAD
- △ PERFIL DE CUALQUIER SUPERFICIE
- ∩ PERFIL DE CUALQUIER LINEA
- ↑ VARIACION
- ⊕ POSICION REAL
- ◎ CONCENRICIDAD
- ≡ SIMETRIA

A MENOS QUE SE ESPECIFIQUE DE OTRA MANERA, LAS TOLERANCIAS DE LAS DIMS; SON LAS SIGUIENTES:

	X	XX	XXX	XXXX
PULG	±.1	±.02	±.005	±.0005
mm	±0.5	±0.13	±0.013	

ANG. ±.50 GRADOS
ELIMINAR REBABAS Y ORILLAS FILOSAS DEL BORDE.

PULG .003-.015 mm 0.1-0.4
FILETEAR ESQUINA: PULG .020 mm 0.5
MAQUINAR SUPERFICIES
PULG 125 mm 3.2

DIMS METRICAS MOSTRADAS [PARENTESIS]

DIBUJADO POR: Daniel Muñoz	04-13-2009
APROBADO POR:	
TERCER ANGULO DE PROYECCION	FECHA EDS: 02-22-2009 REV. FORMATO: F
CONFIDENCIAL: ESTE DIBUJO Y SU INFORMACION SON PROPIEDAD DE USO EXCLUSIVO Y CONFIDENCIAL DE A.O.SMITH CORP. Y NO DEBERAN SER REVELADOS, DUPLICADOS, DISTRIBUIDOS O USARSE DE OTRA MANERA SIN EL CONSENTIMIENTO ESCRITO DE A.O. SMITH CORP. -TODOS LOS DERECHOS RESERVADOS.ASME Y14.5M 1994	

 ELECTRICAL PRODUCTS COMPANY <small>A DIVISION OF A. O. SMITH CORPORATION</small>	
DESCRIPCION: CONNECTION DIAGRAM EXTERNAL	
TAMAÑO: A	NUMERO DE DIBUJO: 627103-006
ESCALA:NONE	HOJA: 1

版本	ECO	编制	日期	批准	日期
B	0001487	D.MUÑOZ	04-13-2009	M.ARGUELLES	04-13-2009

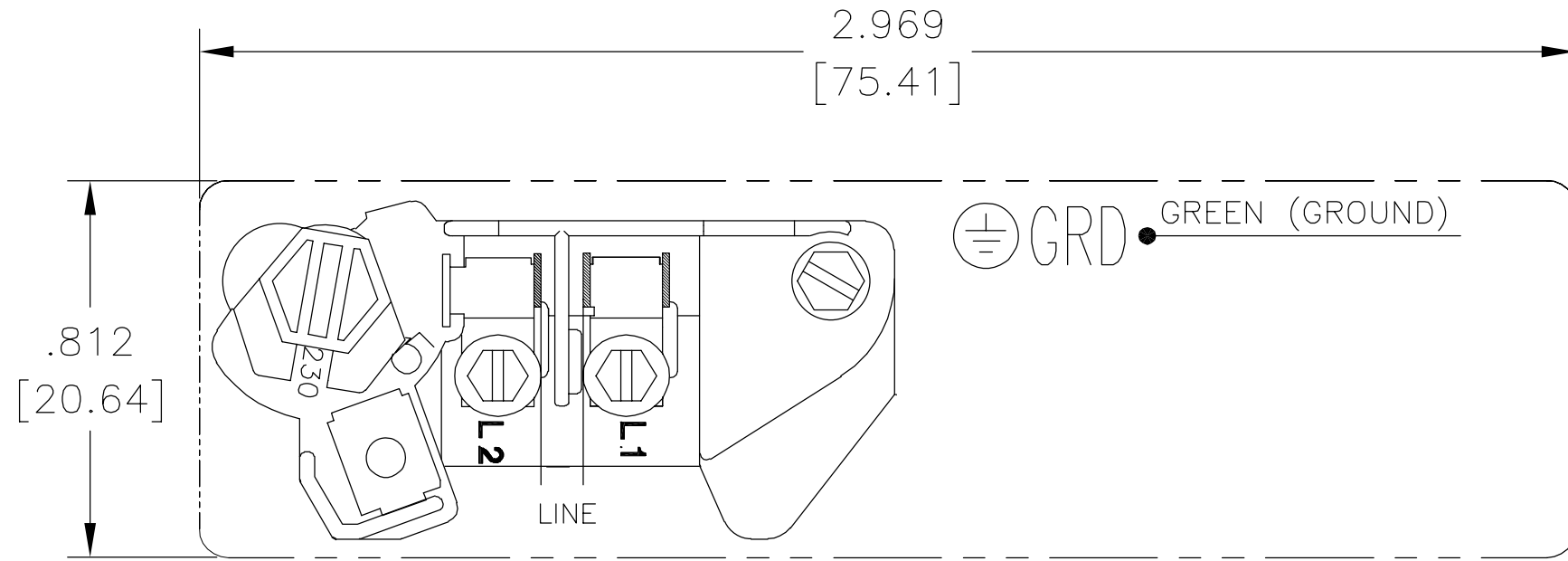

- 形位公差
- 平面度
- 直线度
- ∠ 倾斜度
- ⊥ 垂直度
- // 平行度
- 圆度
- ⊘ 圆柱度
- △ 面轮廓度
- ∩ 线轮廓度
- ↗ 圆跳动
- ⊕ 位置度
- ◎ 同轴度
- ≡ 对称度

除另有注明
尺寸公差如下:

	X	XX	XXX	XXXX
英寸	±.1	±.02	±.005	±.0005
毫米	±0.5	±0.13	±0.013	
角度	±.50 度			
清理毛刺和尖棱				
英寸	.003-.015	毫米	0.1-0.4	
内圆角				
英寸	.020	毫米	0.5	
表面粗糙度				
英制	125	米制	3.2	

米制尺寸显示在 []

绘图:	Daniel Muñoz	04-13-2009
批准:		
第三角投影		图纸格式发布日期 02-22-2009 图纸格式版本 F
机密: 本图纸及相关信息所有权归A. O. SMITH公司所有。未经A. O. SMITH公司书面授权, 不得泄露、复制、传播或作其他用途。—版权所有		
ASME Y14.5M 1994		

 innovation has a name.		ELECTRICAL PRODUCTS COMPANY <small>A DIVISION OF A. O. SMITH CORPORATION</small>	
名称		CONNECTION DIAGRAM EXTERNAL	
图幅	A	图号	627103-006
比例	NONE	页号	1